

2020

SAYL ✨



PRODUCTOS EXCLUSIVOS  
**EXCLUSIVE PRODUCTS**  
PRODUITS EXCLUSIFS

Diseñamos y fabricamos todos nuestros productos.

*We design and manufacture all our products.*

Nous dessinons et nous fabriquons tous nos produits.



INNOVACIÓN CONTINUA  
**CONTINUOUS INNOVATION**  
INNOVATION CONTINUE

La obsesión por mejorar nuestros productos y servicios es el eje vertebrador de todas nuestras acciones.

*The obsession to improve our products and services is the backbone for all our actions.*

L'obsession pour améliorer nos produits et services, est la colonne vertébrale de toutes nos actions.



PRODUCTOS SIN INSTALACIÓN  
**PLUG&PLAY PRODUCTS**  
PRODUITS SANS INSTALLATION

Sin necesidad de costes de instalación, conectar y listo para funcionar, sin costes extras.

***There are no installation costs, just plug & play.***

Sans nécessité de coût d'installation connecter et prêt à fonctionner sans coût extra.



CALIDAD  
**QUALITY**  
QUALITÉ

Productos diseñados con los mejores componentes del mercado, pasando los más exhaustivos controles de calidad.

***Our products are designed with the best components of the market, following a rigorous quality control check.***

Produits dessinés avec les meilleurs composants du marché en passant par les plus exhaustifs contrôles de qualité.



SOPORTE  
**SUPPORT**  
SUPPORT

Un equipo multidisciplinar con amplia experiencia en el sector para dar respuesta a todas tus necesidades.

***Our multidisciplinary team with a wide experience on the sector will give an answer to your needs.***

Un équipement multidisciplinaire avec une grande expérience dans le secteur pour donner réponses à toutes vos demandes.



RESPONSABILIDAD  
**RESPONSIBILITY**  
RESPONSABILITÉ

Máximo compromiso en cuidar de nuestro planeta, diseñamos y trabajamos con proveedores alienados con este principio básico.

*We are fully committed to the preservation of our planet, that is why we design and work with supplier in alignment with this basic principle*

Engagement maximum pour le respect de notre planète, nous dessinons et travaillons avec des fournisseurs en accord avec le principe basique.



CONTROL DE LA PRODUCCIÓN  
**PRODUCTION CONTROL**  
CONTRÔLE DE LA PRODUCTION

Fabricamos todos nuestros productos para así poder garantizando la calidad y el servicio del los mismos.

***We manufacture all our product to ensure their quality and service.***

Nous fabriquons tous nos produits pour pouvoir ainsi garantir la qualité et le service d'eux-même.



CERCANÍA Y FLEXIBILIDAD  
**CLOSENESS AND FLEXIBILITY**  
PROXIMITÉ ET FLEXIBILITÉ

Trabajamos junto a nuestros partners para crear nuevas líneas de producto, mejorar los existentes o dar respuesta a proyectos personalizados.

***We work with our partners to create new product lines, improve the existing products and to offer a solution for tailor-made projects.***

Nous travaillons près de nos partenaires pour créer de nouvelles lignes de produits, améliorer leur durée de vie et donner des réponses pour des projets personnalisés.



**SAYL** ✨  
BE A "SAYL PARTNER"



COMPROMETIDOS CON NUESTRO PLANETA  
 WE ARE COMMITTED TO THE ENVIRONMENT  
 NOUS SOMMES ENGAGÉS POUR NOTRE PLANÈTE

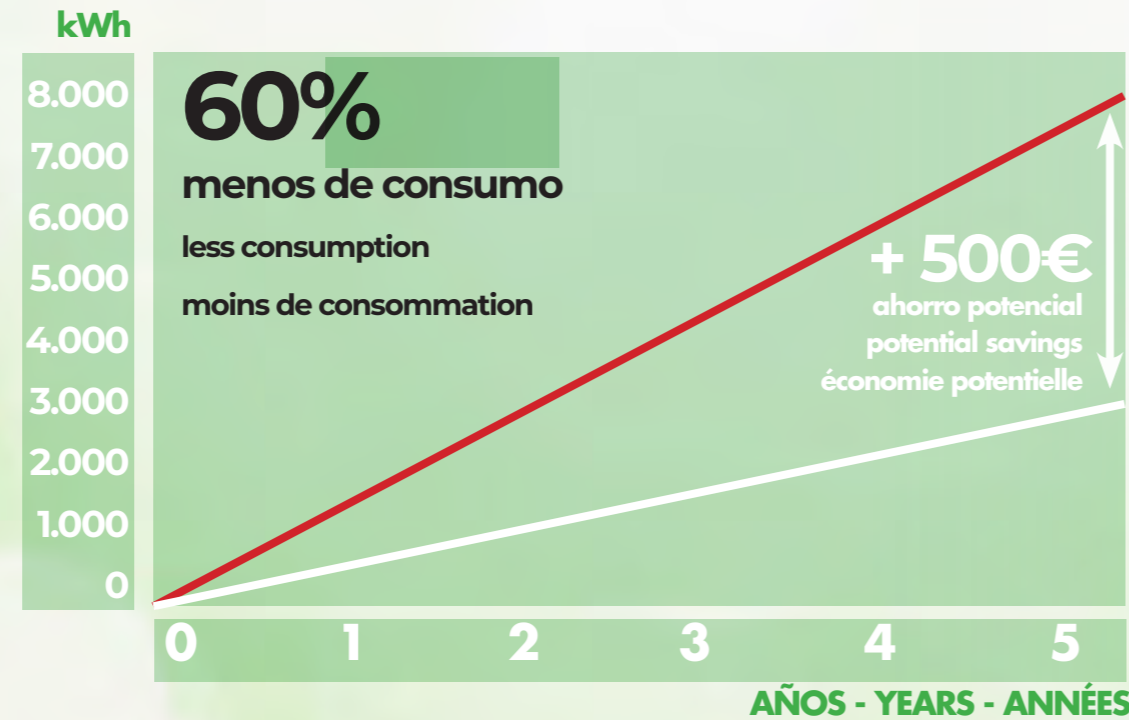

Comparativa realizada con las vitrinas LOGIC TAPAS de Sayl de nueva generación estimando un uso de 16h diarias durante 5 años a 0.1169€/kWh.  
**Cost comparison of new generation SAYL LOGIC TAPAS estimated usage of 16 hours daily during 5 years at 0.1169€/kwh**  
 Comparatif avec les vitrines LOGIC TAPAS de Sayl nouvelle génération, estimation d'une utilisation de 16 h par jour pendant 5 ans à 0.1169€/kwh



iluminación de **bajo** consumo  
**LOW** consumption lighting  
 illumination **basse** consommation

**25%**  
 menos de plástico  
 less plastic  
 de **plastique** en moins

termostatos con modo **eco**  
**eco** mode thermostat  
 thermostats mode **éco**

**INNER TUBE**  
**30%** + eficiencia  
 + efficiency  
 + d'efficacité

**ED FAN**  
**75%** + eficiencia  
 + efficiency  
 + d'efficacité

gases naturales R600a-R290  
 natural gases R600a-R290  
 gaz naturels R600a-R290

**0.00%**  
 degradación en la capa de ozono  
 reduction of ozone layer degradation  
 dégradation dans la couche d'ozone

**99.8%**  
 reducción calentamiento atmosférico (GWP)  
 reduction of global warming (GWP)  
 réduction réchauffement atmosphérique

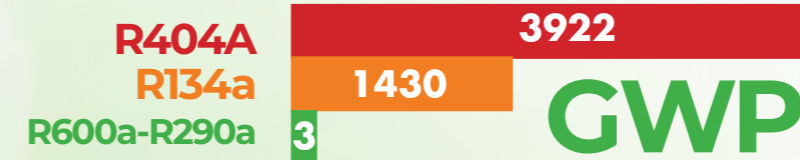

aislante base agua  
 water based insulation  
 isolation à base d'eau

**0.0%** HFC'S

compresores AE  
 compressor AE  
 compresseurs AE  
 + eficiencia  
 + efficiency  
 + d'efficacité

**50%**

**90%**  
 reciclable  
 recyclable  
 recicable

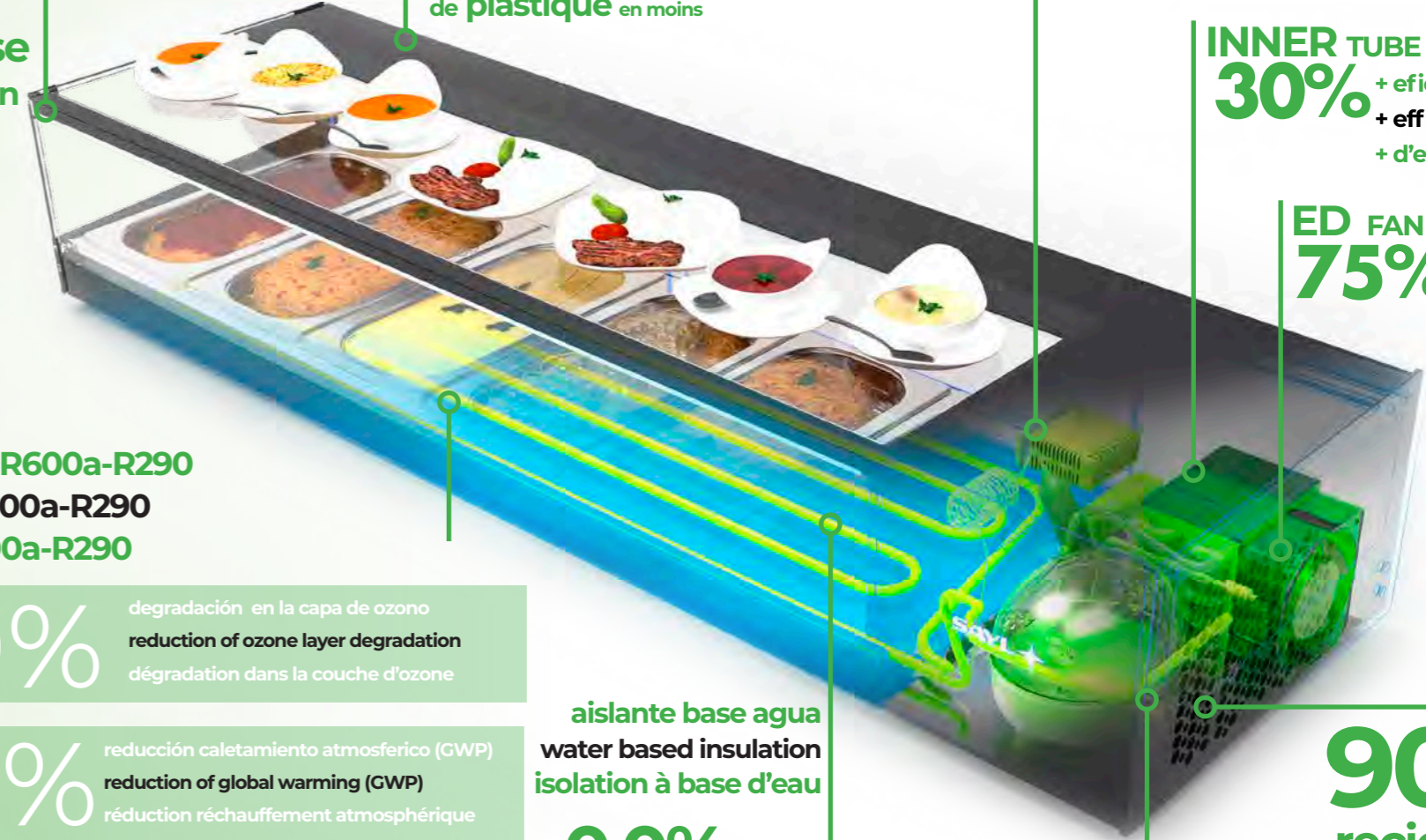



### PITAGORAS

Nuevo expositor Pitágoras, la opción más económica para realizar una sencilla barrera de protección entre tus productos y clientes.

*New Pitagoras display, the cheapest option to create a simple protection barrier between your products and customers.*

Nouvelle vitrine neutre Pythagore, l'option la plus économique pour réaliser une simple barrière de protection entre les produits et les clients.

### ZEPPELIN

¡Especialmente diseñado para proteger los productos y hacer de barrera protectora con el cliente sin renunciar a la practicidad de trabajar en barra!

*Specially designed to protect the products and act as a protective barrier with the customer without giving up the practicality of working at the counter.*

Spécialement conçue pour protéger les produits et faire une barrière protectrice avec le client sans renoncer à la pratique de travailler au bar.



### LOGIC TRIPLE

Máxima capacidad y flexibilidad! Con uno o dos estantes regulables con iluminación incorporada, la nueva Logic Triple es la vitrina de tapas más versátil del mercado.

*Maximum capacity and flexibility! With one or two adjustable shelves with built-in lighting, the new Triple Logic is the most versatile tapas display case of the market!*

Capacité et maniabilité maximum! avec une ou deux étagères réglables avec illumination incorporée la nouvelle Logic Triple est la vitrine à tapas la plus versatile du marché.

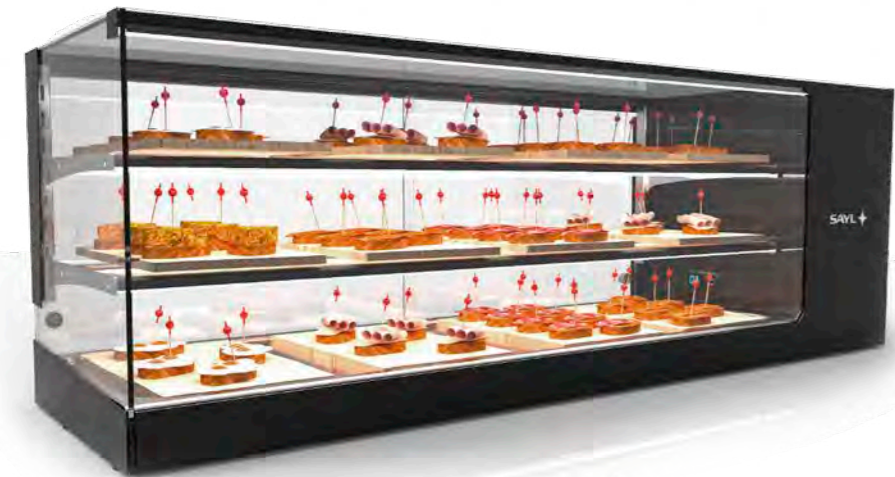

### VISION

¡Los expositores más completos del mercado! Completamente transparentes, sin estructura que perjudique la visualización del producto, y con estantes regulables con doble iluminación en cada estante.

*The most complete exhibitors on the market! Completely transparent, without structure that prevents the visualization of the product, with adjustable shelves with double lighting on each one*

Les vitrines neutres les plus complètes du marché! Complètement transparentes sans structures qui pourraient porter préjudice à la visualisation des produits, avec étagères réglables, et double illumination à chaque étage.

### INTEGRAS GRAB&GO

Sin barreras para el autoservicio, las nuevas Integras Grab&Go mantienen tus productos a la temperatura deseada sin puertas ni elementos que pueden bloquear la venta.

*Without barriers for self-service, the new Integras Grab&Go keep your products at the desired temperature without doors or elements that could block sales.*

Sans barrières pour le libre service, les nouvelles Integras maintiennent vos produits à la température désirée sans portes ni éléments qui peuvent bloquer la vente.



+2/+15 °C  
PAK



PAK RECTA  
50

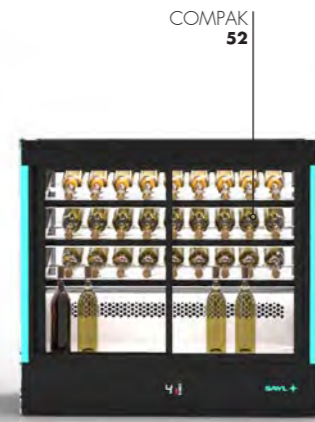

COMPAK  
52



PAK CURVADA  
48

INTEGRA DROP-IN



INTEGRAS DROP-IN  
39

INTEGRA

INTEGRA 60 MINI  
24  
26  
27 N



INTEGRA 60  
29  
29  
29 N



INTEGRA 100  
30  
32  
33 N



INTEGRA 120  
34  
36  
37 N



+2/+15 °C  
GN I-I



SPLENDID  
108



MAXISELF  
102



XL  
96



BLOCK  
100

+90 °C  
GN I-I



SPLENDID  
110



MAXISELF  
106

+90 °C  
SPECIAL



HONDA  
70

+2/+15 °C  
SPECIAL



VELA  
62



TOPPING MINI  
114



QBO  
66



TOPPING BOX  
112



TOWER  
58



DOLCE  
72

+2/+15 °C

TAPAS



+2/+15 °C

SUSHI



+90 °C

TAPAS



2 | 3

BUFFETS

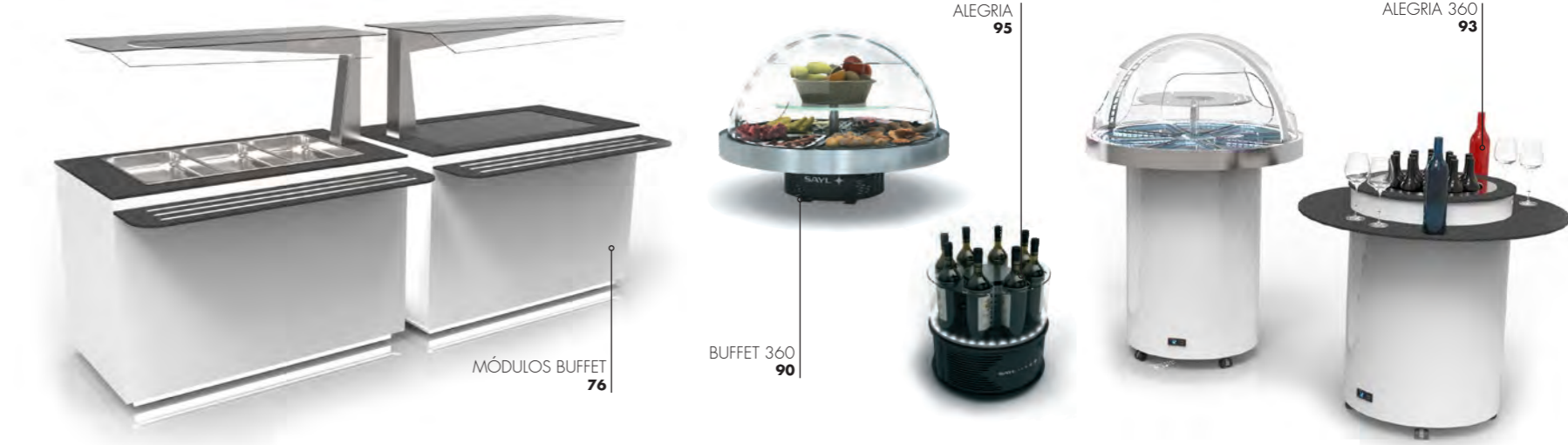

DROP-IN & REMOTOS



NEUTROS



HORIZONTALES



ELEMENTOS VERTICALES



PLANCHAS - COCINAS



HORNOS



HORECA



ASADORES



LAVAVAJILLAS



GUIA ORIENTATIVA PARA LA LINEA DE EXPOSICIÓN SAYL  
**SAYL EXHIBITION LINE ORIENTATION GUIDE**  
 GUIDANCE LINE GUIDE POUR L'EXPOSITION SAYL

**SANDWICH**

INTEGRA*	16
PAK - COMPAK*	44
TOWER*	58
VELA*	64
QBO*	66
DOLCE	72
XL	98
BLOCK	100
MAXISELF	102
SPLENDID	108

**TAPAS**

INITEGRA CT*	16
HONDA	70
DOLCE	75
MAXISELF BAÑO MARIA	107
SPLENDID BAÑO MARIA	111
LOGIC BAÑO MARIA	123
LOGIC TRIPLE BAÑO MARIA	133
SHARK BAÑO MARIA	141
SHARK 2P BAÑO MARIA	147
SELF SERVICE BAÑO MARIA	151
STANDAR BAÑO MARIA	157
DOS PISOS BAÑO MARIA	161

**DESSERT**

INTEGRA*	16
PAK - COMPAK*	44
TOWER*	58
VELA*	64
QBO*	66
DOLCE	72
XL	98
BLOCK	100
MAXISELF	102
SPLENDID	108

**BAKERY**

INITEGRA CT*	16
HONDA	70
DOLCE	75
MAXISELF SAHARA	106
SPLENDID SAHARA	110
LOGIC SAHARA	122
LOGIC TRIPLE SAHARA	132
SHARK SAHARA	140
SHARK 2P SAHARA	146
SELF SERVICE BAÑO SAHARA	150
STANDAR BAÑO SAHARA	156
DOS PISOS BAÑO SAHARA	160

**SALAD**

INTEGRA*	16
PAK - COMPAK*	44
TOWER*	58
VELA*	64
QBO*	66
HONDA	70
DOLCE	72
BUFFET	76
ALEGRIA	94
XL	98
BLOCK	100
MAXISELF	102
SPLENDID	108
TOPPING	112
LOGIC	118
LOGIC SUSHI	122
LOGIC TRIPLE	128
CUBE	134
SHARK	136
SELF SERVICE	148
SUM	152
STANDAR	154
DOS PISOS	158
GRUPO REMOTO	162
NEUTRO	170
4 CARAS PASTRY	184
4 CARAS CARNE	186

**TOPPING**

TOPPING BOX	112
TOPPING MINI	114

**SUSHI**

INTEGRA*	16
PAK - COMPAK*	44
TOWER*	58
VELA*	64
QBO*	66
XL	98
BLOCK	100
MAXISELF	102
SPLENDID	108
LOGIC SUSHI	122
SHARK	136
SUM	152
STANDAR	154
4 CARAS PASTRY	184

**PIZZA**

INITEGRA CT*	16
HONDA	70
DOLCE	75
BUFFET	76
MAXISELF SAHARA	106
SPLENDID SAHARA	110
LOGIC SAHARA	122
LOGIC TRIPLE SAHARA	132
SHARK SAHARA	140
SHARK 2P SAHARA	146
SELF SERVICE BAÑO SAHARA	150
STANDAR BAÑO SAHARA	156
DOS PISOS BAÑO SAHARA	160

**FRUIT**

INTEGRA*	16
PAK - COMPAK*	44
TOWER*	58
VELA*	64
QBO*	66
HONDA	70
DOLCE	72
BUFFET	76
ALEGRIA	94
XL	98
BLOCK	100
MAXISELF	102
SPLENDID	108
TOPPING	112
LOGIC	118
LOGIC SUSHI	122
LOGIC TRIPLE	128
CUBE	134
SHARK	136
SELF SERVICE	148
SUM	152
STANDAR	154
DOS PISOS	158
GRUPO REMOTO	162
NEUTRO	170
4 CARAS PASTRY	184
4 CARAS CARNE	186

**SEAFOOD**

XL	98
BLOCK	100

**BUFFET**

INTEGRA*	16
PAK - COMPAK*	44
BUFFET	76
ALEGRIA	94
XL	98
BLOCK	100
MAXISELF	102
SELF SERVICE	148

**BUFFET**

INTEGRA	16
BUFFET	76
MAXISELF SAHARA	107
MAXISELF BAÑO MARIA	108
SELF-SERVICE SAHARA	148
SELF-SERVICE BAÑO MARIA	149

**MEAT**

INTEGRA*	16
PAK - COMPAK*	44
XL	98
BLOCK	100
MAXISELF	102
SPLENDID	108
LOGIC SUSHI	122
4 CARAS CARNE	186

**TAPAS**

BUFFET	72
XL	94
BLOCK	98
MAXISELF	100
SPLENDID	102
TOPPING	108
LOGIC	112
LOGIC SUSHI	118
LOGIC TRIPLE	122
CUBE	128
SHARK	134
SELF SERVICE	136
SUM	148
STANDAR	152
DOS PISOS	154
GRUPO REMOTO	158

**CHURROS**

INITEGRA CT*	16
HONDA	70
DOLCE	75
BUFFET	76
MAXISELF SAHARA	106
SPLENDID SAHARA	110
LOGIC SAHARA	122
LOGIC TRIPLE SAHARA	132
SHARK SAHARA	140
SHARK 2P SAHARA	146
SELF SERVICE BAÑO SAHARA	150
STANDAR BAÑO SAHARA	156
DOS PISOS BAÑO SAHARA	160

**DRINKS**

INTEGRA*	16
PAK - COMPAK*	44
TOWER*	58
VELA*	64
QBO*	66
BUFFET	76
ALEGRIA	94

**SNACKS**

INTEGRA*	16
PAK - COMPAK*	44
TOWER*	58
VELA*	64
QBO*	66
DOLCE	72

**SALSAS**

MAXISELF BAÑO MARIA	107
SPLENDID BAÑO MARIA	111
LOGIC BAÑO MARIA	123
LOGIC TRIPLE BAÑO MARIA	133
SHARK BAÑO MARIA	141
SHARK 2P BAÑO MARIA	147
SELF SERVICE BAÑO MARIA	151
STANDAR BAÑO MARIA	157
DOS PISOS BAÑO MARIA	161



SAYL ✨

## EL POETA ERES TÚ, NOSOTROS LAS PALABRAS

DISEÑA TU ESTABLECIMIENTO A TU GUSTO Y NOSOTROS TE PROPORCIONAMOS  
LOS ELEMENTOS MÁS INTEGRABLES PARA CADA USO.

## YOU ARE THE POET, WE ARE THE WORDS

DESIGN YOUR BUSINESS JUST LIKE YOU LIKE IT AND WE WILL PROVIDE YOU WITH THE  
MOST INTEGRABLE ELEMENTS FOR EACH USE

## LE POÈTE C'EST TOI, L'ALPHABET C'EST NOUS.

DESSINE TON ÉTABLISSEMENT A TON GOÛT ET NOUS ADAPTERONS LES ÉLÉMENTS  
QUI S'INTÈGRERONT POUR CHAQUE UTILISATION



NUEVA FAMILIA DE VITRINAS SAYL, PERSONALIZABLES Y DISEÑADAS PARA INTEGRAR EN CUALQUIER ESPACIO.

**NEW FAMILY OF SAYL DISPLAYS DESIGNED TO BE INTEGRATED IN ANY KIND OF SPACE**

NOUVELLE FAMILLE DE VITRINES SAYL, PERSONNALISABLES ET DESSINÉES POUR INTÉGRER DANS N'IMPORTE QUEL ESPACE.



SAYL  
**INTEGRA** LINE



VISIBILIDAD SIEMPRE PERFECTA  
**ALWAYS PERFECT VISIBILITY**  
VISIBILITE TOTALE

Construida con cristales cámara de alta calidad para asegurar la perfecta visibilidad, incluso en las condiciones más exigentes de temperatura y humedad.

*The Integra line is built with high quality double glazed glass to ensure perfect visibility, even for the most demanding temperature and humidity conditions.*

Double vitrage de haute qualité pour assurer une parfaite visibilité avec les conditions plus exigeantes de température et d'humidité.



CONSTRUCCIÓN SIN TORNILLERÍA  
**SCREW-LESS CONSTRUCTION**  
CONSTRUCTION SANS VISSERIE

Construida en cristal y con ausencia total de tornillería para que nada interrumpa la visibilidad del producto y facilite las operaciones de limpieza.

*Built in glass without external screws to facilitate the product visibility and the cleaning.*

Construction des vitres avec absence totale de visserie, pour plus de visibilité du produit et plus de facilité de nettoyage.



PLUG&PLAY  
**PLUG&PLAY**  
PLUG&PLAY

Sin necesidad de instalación ni desagüe, aparato compacto listo para su uso.

*No need of installation and drainage. Compact device ready to be used.*

Sans nécessité d'installation ni de vidange, appareil compact prêt à l'emploi.



POTENTE  
**POWERFUL**  
PUISSANCE

Equipadas con potentes grupos frigoríficos y con los mejores componentes del mercado, para asegurar las mejores prestaciones en todo momento.

*Equipped with the most powerful refrigeration unit and with the best components of the market to ensure the highest performance a all times.*

Équipées de groupes frigorifiques puissants, et avec les meilleurs composants du marché pour assurer une meilleure prestation à tous moments.



OPCIÓN AUTOSERVICIO  
**SELF-SERVICE OPTION**  
 OPTION SELF-SERVICE

Posibilidad de autoservicio gracias al acceso delantero mediante puertas o con opción grab&go.

*Self-service option thanks to front access sliding doors or to the grab&go option.*

Possibilité de self-service grâce à l'accès à l'avant au moyen de portes ou option sans portes.



DOBLE LED EN CADA ALTURA  
**DOUBLE LED IN EVERY SHELF**  
 DOUBLE LEDS A CHAQUE ÉTAGE

El producto se ilumina desde dos líneas de luz para conseguir una perfecta iluminación del producto sin sombras indeseables.

*The product is illuminated from two light lines to obtain the perfect lighting of the product without unwanted shadows.*

Les produits sont éclairés par deux lignes de lumière, afin d'avoir une illumination des produits sans ombre indésirable.



PERSONALIZABLE  
**CUSTOMIZABLE**  
 CUSTOMISABLE

Bases personalizables en altura, colores y acabados.

*The bottom structure can be personalized in height and colour.*

Bases personnalisables en hauteur et coloris.



ESPECTACULAR TERMOSTATO  
**BIG SIZE THERMOSTAT**  
 THERMOSTAT SPECTACULAIRE

Termostato táctil de gran tamaño de última generación, fácil e intuitivo, con posibilidades de conectividad para tareas de supervisión.

*Large size latest generation touch-screen thermostat, easy and intuitive with possibility of connectivity for monitoring task.*

Thermostat digital grande dimension de dernière génération, facile et intuitif avec possibilités de connectivité pour tâches de supervision.

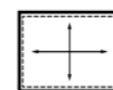

HABILABILIDAD REGULABLE  
**OPTIMISATION OF SPACE**  
 HABITABILITÉ RÉGLABLE

Grandes estantes de cristal templado regulables, que permiten aumentar la habitabilidad del espacio interior al máximo.

*Large adjustable double glazed shelves to make the best use of the interior available space.*

Grandes étagères réglables en verre trempé qui permettent d'augmenter au maximum l'habitabilité de l'espace intérieur.





COMBINA MÓDULOS FRIO, NEUTRO Y CALIENTE CON EL MISMO ACABADO  
 YOU CAN COMBINE COLD, NEUTRAL AND WARM UNITS WITH THE SAME FINISHING  
 DESSINÉS AFIN D'OBTENIR UN MAXIMUM DE CAPACITÉ ET UNE PARFAITE VISIBILITÉ DU PRODUIT



RUEDAS CON FRENOS INCLUIDAS  
 WHEELS WITH BRAKES INCLUDED  
 ROULETTES ET FREINS INCLUS



VERSIONES COMPACTAS DE TODOS LOS MODELOS PARA INSTALAR SOBRE-BARRA  
 COMPACT DESIGN OF ALL MODELS FOR COUNTERTOP INSTALLATION  
 VERSIONS COMPACTES A INSTALLER SUR DES COMPTOIRS DE BAR DE TOUS MODÈLES.



DISEÑADAS PARA OBTENER LA MÁXIMA CAPACIDAD CON UNA PERFECTA VISIBILIDAD DEL PRODUCTO  
 DESIGNED TO OBTAIN THE HIGHEST CAPACITY WITH A PERFECT VISIBILITY OF THE PRODUCT  
 DESSINÉS AFIN D'OBTENIR UN MAXIMUM DE CAPACITÉ ET UNE PARFAITE VISIBILITÉ DU PRODUIT.

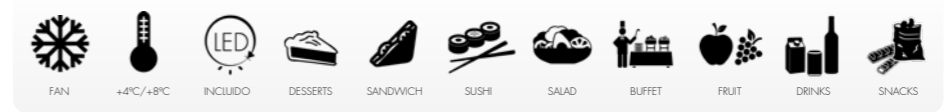

IN-60-115A



IN-60-85



IN-60-115



**VITRINA INTEGRA COMPACTA REFRIGERADA 60**

	MEDIDAS	Nº ESTANTES REGULABLES	ACCESO		TEMP. (FOOD ZONE)	RUEDAS	LEDS ESTANTE
			FRONTAL	TRASERO			
<b>IN-60-85</b>	600x600x850	2	NO	SI	+4/+8°C	NO	SI
<b>IN-60-115</b>	600x600x1150	3	NO	SI	+4/+8°C	NO	SI
<b>IN-60-115A</b>	600x600x1150	3	SI	SI	+4/+8°C	NO	SI

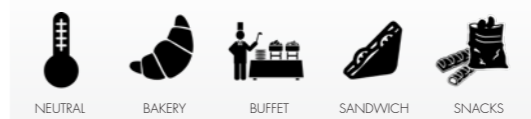
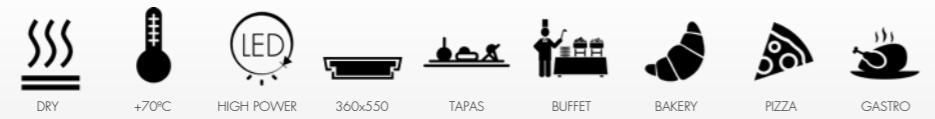

IN-60-90CG

IN-60-90C

IN-60-90AC

IN-60-60C

IN-60-50N

IN-60-80N

IN-60-80AN



**VITRINA INTEGRAL COMPACTA CALIENTE 60**

	MEDIDAS	Nº ESTANTES REGULABLES	ACCESO FRONTAL	ACCESO TRASERO	TEMP. (FOOD ZONE)	RUEDAS	LEDS ESTANTE
<b>IN-60-60CG</b>	600x600x650	2	ABIERTO	SI	+60°C	NO	SI
<b>IN-60-60C</b>	600x600x600	2	NO	SI	+60°C	NO	SI
<b>IN-60-90C</b>	600x600x900	3	NO	SI	+60°C	NO	SI
<b>IN-60-90AC</b>	600x600x900	3	SI	SI	+60°C	NO	SI
<b>IN-60-90CG</b>	600x600x950	3	ABIERTO	SI	+60°C	NO	SI

**VITRINA INTEGRAL COMPACTA NEUTRA 60**

	MEDIDAS	Nº ESTANTES REGULABLES	ACCESO FRONTAL	ACCESO TRASERO	TEMP. (FOOD ZONE)	RUEDAS	LEDS ESTANTE
<b>IN-60-50N</b>	600x600x520	2	NO	SI	NEUTRAL	NO	SI
<b>IN-60-80N</b>	600x600x820	3	NO	SI	NEUTRAL	NO	SI
<b>IN-60-80AN</b>	600x600x820	3	SI	SI	NEUTRAL	NO	SI

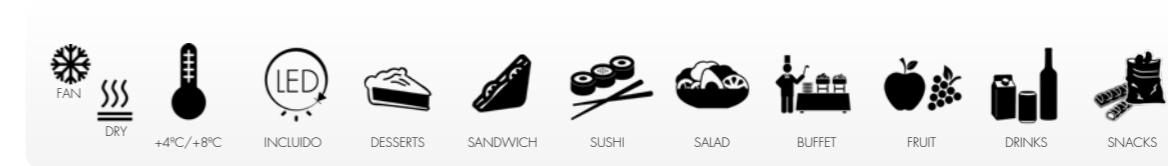

**VITRINA INTEGRA CON BASE 60**

	MEDIDAS	Nº ESTANTES REGULABLES	ACCESO FRONTAL	ACCESO TRASERO	TEMP. (FOOD ZONE)	RUEDAS	LEDS ESTANTE
<b>IN-60-110</b>	600x600x1100	2	NO	SI	+4/+8°C	SI	SI
<b>IN-60-140</b>	600x600x1400	3	NO	SI	+4/+8°C	SI	SI
<b>IN-60-140A</b>	600x600x1400	3	SI	SI	+4/+8°C	SI	SI
<b>IN-60-140G</b>	600x600x1400	3	ABIERTO	SI	+6/+10°C	SI	SI
<b>IN-60-110CG</b>	600x600x110	2	ABIERTO	SI	+60°C	SI	SI
<b>IN-60-110C</b>	600x600x1100	2	NO	SI	+60°C	SI	SI
<b>IN-60-140C</b>	600x600x1400	3	NO	SI	+60°C	SI	SI
<b>IN-60-140AC</b>	600x600x1400	3	SI	SI	+60°C	SI	SI
<b>IN-60-140GC</b>	600x600x1400	3	ABIERTO	SI	+60°C	SI	SI
<b>IN-60-110N</b>	600x600x1100	2	NO	SI	NEUTRAL	SI	SI
<b>IN-60-140N</b>	600x600x1400	3	NO	SI	NEUTRAL	SI	SI
<b>IN-60-140AN</b>	600x600x1400	3	SI	SI	NEUTRAL	SI	SI
<b>IN-60-140GN</b>	600x600x1400	3	SI	SI	NEUTRAL	SI	SI



IN-100-140



IN-100-140A



VITRINA INTEGRA CON BASE 100

	MEDIDAS	Nº ESTANTES REGULABLES	ACCESO FRONTAL	ACCESO TRASERO	TEMP. (FOOD ZONE)	RUEDAS	LEDS ESTANTE
<b>IN-100-140</b>	1000x600x1400	3	NO	SI	+4/+8°C	SI	SI
<b>IN-100-140A</b>	1000x600x1400	3	SI	SI	+4/+8°C	SI	SI
<b>IN-100-140CG</b>	1000x600x1400	3	ABIERTO	SI	+60°C	SI	SI
<b>IN-100-140C</b>	1000x600x1400	3	NO	SI	+60°C	SI	SI
<b>IN-100-140AC</b>	1000x600x1400	3	SI	SI	+60°C	SI	SI
<b>IN-100-140N</b>	1000x600x1400	3	NO	SI	NEUTRA	SI	SI
<b>IN-100-140PN</b>	1000x600x1400	3	SI	SI	NEUTRA	SI	SI



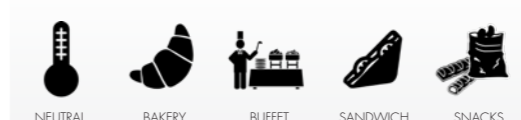
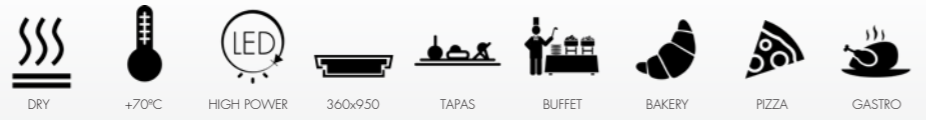

IN-100-90C

IN-100-90AC



IN-100-80N

IN-100-80AN



VITRINA INTEGRAL COMPACTA CALIENTE 100

	MEDIDAS	Nº ESTANTES REGULABLES	ACCESO FRONTAL	ACCESO TRASERO	TEMP. (FOOD ZONE)	RUEDAS	LEDS ESTANTE
<b>IN-100-90CG</b>	1000x600x950	3	ABIERTO	SI	+60°C	NO	SI
<b>IN-100-90C</b>	1000x600x900	3	NO	SI	+60°C	NO	SI
<b>IN-100-90AC</b>	1000x600x900	3	SI	SI	+60°C	NO	SI

VITRINA INTEGRAL COMPACTA NEUTRA 100

	MEDIDAS	Nº ESTANTES REGULABLES	ACCESO FRONTAL	ACCESO TRASERO	TEMP. (FOOD ZONE)	RUEDAS	LEDS ESTANTE
<b>IN-100-80N</b>	1000x600x820	3	NO	SI	NEUTRA	NO	SI
<b>IN-100-80AN</b>	1000x600x820	3	SI	SI	NEUTRA	NO	SI



IN-120-140



IN-120-140A



VITRINA INTEGRAL CON BASE 120

	MEDIDAS	Nº ESTANTES REGULABLES	ACCESO FRONTAL	ACCESO TRASERO	TEMP. (FOOD ZONE)	RUEDAS	LEDS ESTANTE
<b>IN-120-140</b>	1200x600x1400	3	NO	SI	+4/+8°C	SI	SI
<b>IN-120-140A</b>	1200x600x1400	3	SI	SI	+4/+8°C	SI	SI
<b>IN-120-140C</b>	1200x600x1400	3	NO	SI	+60°C	SI	SI
<b>IN-120-140AC</b>	1200x600x1400	3	SI	SI	+60°C	SI	SI
<b>IN-120-140N</b>	1200x600x1400	3	NO	SI	NEUTRA	SI	SI
<b>IN-120-140AN</b>	1200x600x1400	3	SI	SI	NEUTRA	SI	SI

SAYL  
INTEGRA LINE

INTEGRA

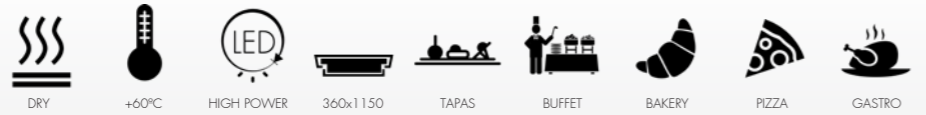

IN-120-90C



IN-120-90AC



IN-120-80N



IN-120-80AN



VITRINA INTEGRAL COMPACTA CALIENTE 120

	MEDIDAS	Nº ESTANTES REGULABLES	ACCESO FRONTAL	ACCESO TRASERO	TEMP. (FOOD ZONE)	RUEDAS	LEDS ESTANTE
<b>IN-120-90C</b>	1200x600x900	3	NO	SI	+60°C	NO	SI
<b>IN-120-90AC</b>	1200x600x900	3	SI	SI	+60°C	NO	SI

VITRINA INTEGRAL COMPACTA NEUTRA 120

	MEDIDAS	Nº ESTANTES REGULABLES	ACCESO FRONTAL	ACCESO TRASERO	TEMP. (FOOD ZONE)	RUEDAS	LEDS ESTANTE
<b>IN-120-80N</b>	1200x600x820	3	NO	SI	NEUTRA	NO	SI
<b>IN-120-80AN</b>	1200x600x820	3	SI	SI	NEUTRA	NO	SI

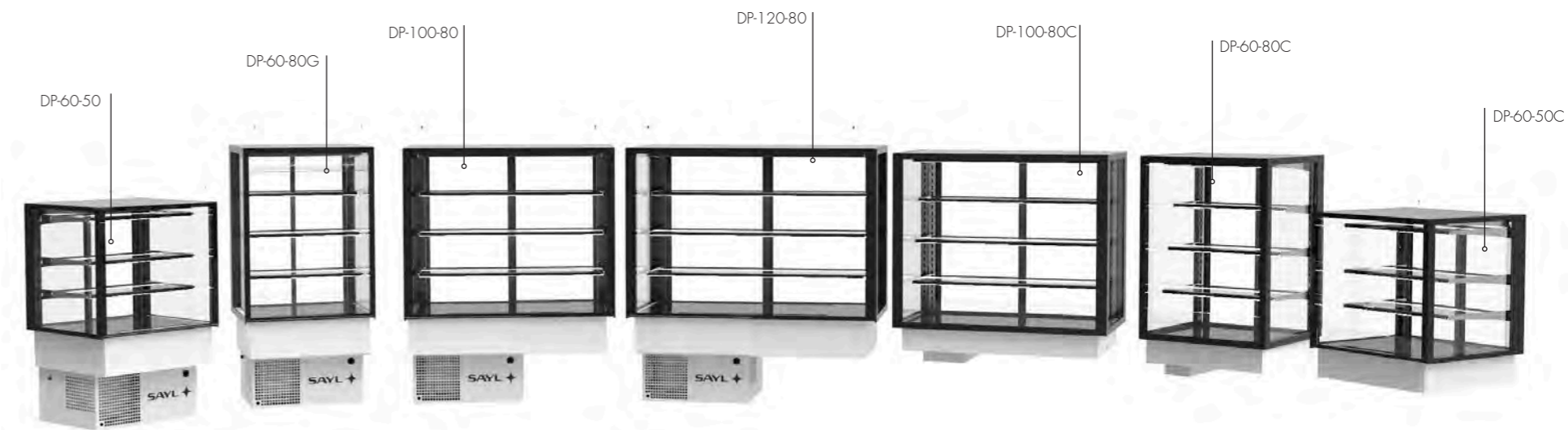
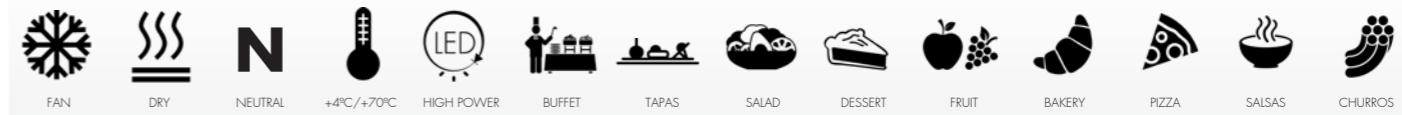

ES Vitrinas refrigeradas para incorporar en barra con el método drop-in, con idénticas características que nuestra gama Integra, cristales cámara, sin tornillería exterior, doble iluminación en cada estante, estantes regulables, potentes y con gran estabilidad de temperaturas.

Ideales para proyectos nuevos donde se requiera de una vitrina completamente integrada en la decoración del establecimiento.

Perfectamente combinables con los modelos caliente y neutro de la gama Integra.

Opción de doble puerta para autoservicio en todos los modelos excepto DP60-50.

ES

EN Refrigerated display cases to integrate in the counter with the drop-in method, with identical features to our Integra Line: tempered glasses, outside screw-less, double lighting in every shelf, adjustable shelves, powerful and steady temperatures.

Perfect for new projects that require a completely integration of the display case with the business decoration.

Combinable with the same version of heated and neutral Integra Line display cases

Self-service double door option in all models except DP60-50.

EN

FR Vitrine réfrigérée à incorporer dans un bar, système drop-in avec les mêmes caractéristiques que toute notre gamme Integra, double vitrage, sans visserie extérieure, double illumination à chaque étagère, étagères réglables, puissance et grande stabilité des températures.

Idéales pour un nouveau projet qui requiert une vitrine complémentaire. S'intègre dans la décoration de l'établissement.

Parfaitement combinable avec les vitrines chaudes et neutres de la gamme INTEGRA.

Option pour tous les modèles d'une double porte pour self service sauver DP60-50.

FR



SAYL

INTEGRA DROP-IN

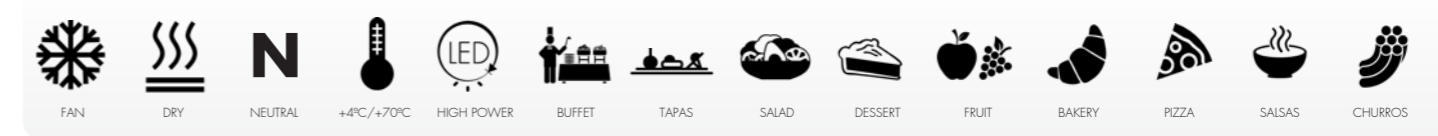

COMBINA ELEMENTOS ESTETICAMENTE IGUALES CON FUNCIONALIDADES DISTINTAS.  
 YOU CAN COMBINE VISUALLY IDENTICAL ELEMENTS THAT OFFER DIFFERENT FUNCTIONALITIES  
 COMBINAISON DES ÉLÉMENTS ESTHÉTIQUEMENT ÉGAUX AVEC LEUR PROPRE FONCTIONNALITÉ.

ESTANTES REGULABLES CON DOBLE ILUMINACIÓN INCORPORADA SIN CABLES  
 REGULABLE SHELVES WITH WIRELESS BUILT-IN DOUBLE LIGHTING  
 ÉTAGÈRES RÉGLABLES AVEC DOUBLE ILLUMINATION INCORPORÉE SANS CÂBLE.

ESPACIO MOTOR OCULTO AL CLIENTE  
 MOTOR SPACE HIDDEN TO THE CLIENT  
 ESPACE MOTEUR OCULTÉ AU CLIENT

LA SOLUCIÓN MÁS ADECUADA PARA CONSEGUIR LA MÁXIMA INTEGRACIÓN  
 THE MOST SUITABLE SOLUTION TO OBTAIN THE MAXIMUM INTEGRATION  
 LA SOLUTION LA PLUS ADÉQUATE POUR OBTENIR UN MAXIMUM D'INTÉGRATION

OLVÍDATE DE CONSTRUIR UNA VITRINA A MEDIDA, USANDO NUESTROS MODULOS DROP-IN GANARAS EN RAPIDEZ, COSTES, FIABILIDAD, FLEXIBILIDAD, PRESTACIONES Y CONSUMO  
 FORGET ABOUT BUILDING A CUSTOM MADE DISPLAY CASE, USING OUR DROP-IN MODULES YOU GAIN IN EFFECTIVENESS, RELIABILITY, FLEXIBILITY, PERFORMANCE AND CONSUMPTION  
 OUBLIEZ L'IDÉE D'UNE VITRINE SUR MESURE EN UTILISANT NOS MODULES DROP-IN VOUS GAGNEREZ EN RAPIDITÉ, COÛTS, FIABILITÉ, FLEXIBILITÉ, PRESTATIONS ET CONSOMMATION

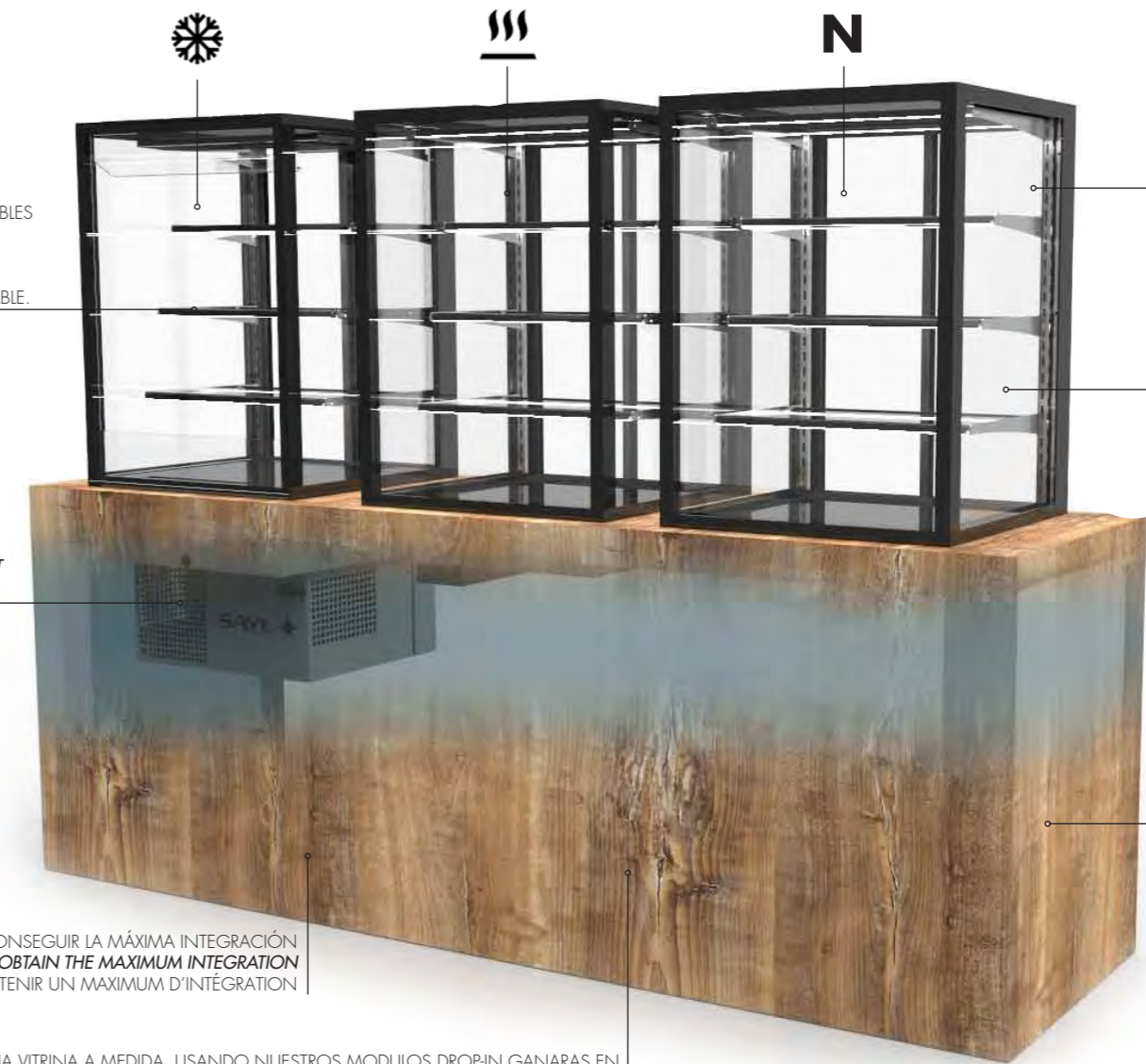

REFRIGERACIÓN, CALOR Y NEUTRO CON ACCESO GRAB&GO, AUTOSERVICIO O SERVICIO  
 REFRIGERATED, HEATED AND NEUTRAL GRAB&GO AND SELF-SERVICE OPTIONAL  
 RÉFRIGÉRATION, CHALEUR ET NEUTRE AVEC ACCÈS SELF-SERVICE OU SERVICE

EXTERIOR EN CRISTAL CÁMARA CON ACABADOS PREMIUM  
 DOUBLE GLAZED GLASSES AND QUALITY FINISHING  
 EXTÉRIEUR EN DOUBLE VITRAGE ET FINITIONS PREMIUM

MÁXIMA FACILIDAD DE INSTALACIÓN SISTEMAS COMPACTOS, COLOCAR Y FUNCIONAR!  
 MAXIMUM EASE OF INSTALLATION, COMPACT SYSTEMS, JUST PLUG&PLAY  
 MAXIMUM DE FACILITÉ D'INSTALLATION SYSTÈMES COMPACTS, INSTALLER ET FONCTIONNER

INTEGRA DROP IN

SIN COMPLICACIONES : CREA EL SOPORTE MÁS ADECUADO PARA TU NEGOCIO E INSERTA NUESTRAS DROP-IN  
 UNCOMPLICATED: BUILD THE MOST SUITABLE FURNITURE FOR YOUR BUSINESS AND JUST INSERT OUR DROP-IN  
 SANS COMPLICATIONS : CRÉEZ LE SUPPORT LE PLUS ADÉQUAT A VOTRE COMMERCE ET Y INSÉREZ NOS DROP-IN



CAJÓN GUIADO PARA FACILITAR EL ACCESO A LIMPIEZA DEL CONDENSADOR Y MANTENIMIENTO  
 GUIDED DRAWER TO FACILITATE THE ACCESS TO THE CONDENSER FOR CLEANING AND MAINTENANCE  
 TIROIR A GLISSIÈRE FACILITANT L'ACCÈS AU CONDENSATEUR POUR LE FONCTIONNEMENT ET LE NETTOYAGE



DP-60-80G



DP-60-80C



IN-60-80N



ZONA DIÁFANA  
 DIAPHANOUS AREA  
 ZONE DIAPHANE

ACCESO POSTERIOR A LOS CONTROLES DE LAS VITRINAS  
 REAR ACCESS TO THE DISPLAY CASE CONTROLS  
 ACCÈS ARRIÈRE AUX CONTRÔLES DES VITRINES

### INTEGRA DROP-IN REFRIGERADA

	MEDIDAS VITRINA	MEDIDA TOTAL	MEDIDA ENCASTE (A x B)	MEDIDA MAX. SOBRE (C)	Nº ESTANTES REGULABLES	MEDIDAS ESTANTE	ACCESO FRONTAL	ACCESO TRASERO	TEMP. (FOOD ZONE)	LEDS ESTANTE
<b>DP-60-50</b>	600x600x515	600x600x850	560x560	100mm	2	520x360	NO	SI	+4/+8°C	SI
<b>DP-60-50G</b>	600x600x515	600x600x850	560x560	100mm	1	520x360	GRAB&GO	SI	+6/+10°C	SI
<b>DP-60-80</b>	600x600x815	600x600x1200	560x560	100mm	3	520x360	NO	SI	+4/+8°C	SI
<b>DP-60-80A</b>	600x600x815	600x600x1200	560x560	100mm	3	520x360	SI	SI	+4/+8°C	SI
<b>DP-60-80G</b>	600x600x815	600x600x1200	560x560	100mm	3	520x300	GRAB&GO	SI	+6/+10°C	SI
<b>DP-100-80</b>	1000x600x815	1000x600x1200	960x560	100mm	3	920x360	NO	SI	+4/+8°C	SI
<b>DP-100-80A</b>	1000x600x815	1000x600x1200	960x560	100mm	3	920x360	SI	SI	+4/+8°C	SI
<b>DP-120-80</b>	1200x600x815	1200x600x1200	1160x560	100mm	3	1120x360	NO	SI	+4/+8°C	SI
<b>DP-120-80A</b>	1200x600x815	1200x600x1200	1160x560	100mm	3	1120x360	SI	SI	+4/+8°C	SI

\*modelos disponibles en grupo remoto.

### INTEGRA DROP-IN CALENTADOR

	MEDIDAS VITRINA	MEDIDA TOTAL	MEDIDA ENCASTE (A x B)	MEDIDA MAX. SOBRE (C)	Nº ESTANTES REGULABLES	MEDIDAS ESTANTE	ACCESO FRONTAL	ACCESO TRASERO	TEMP. (FOOD ZONE)	LEDS ESTANTE
<b>DP-60-50C</b>	600x600x515	600x600x680	560x560	100mm	2	520x360	NO	SI	+70°C	SI
<b>DP-60-50CG</b>	600x600x515	600x600x680	560x560	100mm	2	520x360	GRAB&GO	SI	+70°C	SI
<b>DP-60-80C</b>	600x600x815	600x600x980	560x560	100mm	3	520x360	NO	SI	+70°C	SI
<b>DP-60-80CA</b>	600x600x815	600x600x980	560x560	100mm	3	520x360	SI	SI	+70°C	SI
<b>DP-60-80CG</b>	600x600x815	600x600x980	560x560	100mm	3	520x300	GRAB&GO	SI	+70°C	SI
<b>DP-100-80C</b>	1000x600x815	1000x600x980	960x560	100mm	3	920x360	NO	SI	+70°C	SI
<b>DP-100-80CA</b>	1000x600x815	1000x600x980	960x560	100mm	3	920x360	SI	SI	+70°C	SI
<b>DP-100-80CG</b>	1000x600x815	1000x600x980	960x560	100mm	3	920x360	GRAB&GO	SI	+70°C	SI
<b>DP-120-80C</b>	1200x600x815	1200x600x980	1160x560	100mm	3	1120x360	NO	SI	+70°C	SI
<b>DP-120-80CA</b>	1200x600x815	1200x600x980	1160x560	100mm	3	1120x360	SI	SI	+70°C	SI

### INTEGRA NEUTRA

	MEDIDAS VITRINA	MEDIDA TOTAL	MEDIDA ENCASTE (A x B)	MEDIDA MAX. SOBRE (C)	Nº ESTANTES REGULABLES	MEDIDAS ESTANTE	ACCESO FRONTAL	ACCESO TRASERO	TEMP. (FOOD ZONE)	LEDS ESTANTE
<b>IN-60-50N</b>	600x600x515	600x600x515	SIN ENCASTE	100mm	2	520x360	NO	SI	NEUTRO	SI
<b>IN-60-80N</b>	600x600x815	600x600x815	SIN ENCASTE	100mm	3	520x360	NO	SI	NEUTRO	SI
<b>IN-60-80AN</b>	600x600x815	600x600x815	SIN ENCASTE	100mm	3	520x360	SI	SI	NEUTRO	SI
<b>IN-100-80N</b>	1000x600x815	1000x600x815	SIN ENCASTE	100mm	3	920x360	NO	SI	NEUTRO	SI
<b>IN-100-80AN</b>	1000x600x815	1000x600x815	SIN ENCASTE	100mm	3	920x360	SI	SI	NEUTRO	SI
<b>IN-120-80N</b>	1200x600x815	1200x600x815	SIN ENCASTE	100mm	3	1120x360	NO	SI	NEUTRO	SI
<b>IN-120-80AN</b>	1200x600x815	1200x600x815	SIN ENCASTE	100mm	3	1120x360	SI	SI	NEUTRO	SI

-  FAN
-  +4°C/+8°C
-  INCLUIDO
-  DESSERTS
-  SANDWICH
-  SUSHI
-  SALAD
-  BUFFET
-  FRUIT
-  DRINKS
-  SNACKS

PAK RECTA

COMPAK

PAK CURVADA





VISIBILIDAD TOTAL  
FULL VISIBILITY  
VISIBILITE TOTALE

La zona de exposición es optimizada al máximo eliminando el espacio visual del motor! Maximizando la zona más valiosa de los restauradores para mostrar sus productos!

*The exhibit area is increased through the elimination of the motor visual space, maximizing restaurateurs' most valued area to show their products!*

L'espace d'exposition est maximisée en éliminant l'espace visuel du moteur! En maximisant la zone la plus précieuse de les restaurateurs pour montrer ses produits!



RECLAMO TOTAL  
FULL ADVERTISING  
PUBLICITE TOTALE

Frontales y laterales con iluminación integrada RGB controlada con control remoto para conseguir el mayor impacto en el cliente.

*Integrated lighting on front and side RGB remote controlled to obtain the greatest possible impact on the client*

Façades et latéraux avec illumination intégrale RGB contrôlé avec télé-commande à distance pour obtenir le meilleur impact sur le client



ILUMINACIÓN TOTAL  
FULL LIGHTING  
ILLUMINATION TOTALE

Cada estante dispone de doble iluminación, específicamente colocada para exponer el producto en un inmejorable aspecto, evitando sombras y malas incidencias de luz.

*Every shelf of the pack has a double illumination system strategically placed to keep your products with an unbeatable appearance avoiding all kinds of shades.*

Chaque étagère de la Pak dispose d'une double illumination spécifiquement placée pour maintenir les produits dans un aspect parfait évitant des zones d'ombre et des mauvaises incidences de lumière.



AHORRO TOTAL  
FULL SAVINGS  
ECONOMIE TOTALE

Los cristales con cámara de hasta 22mm de aislamiento garantizan el máximo rendimiento con el mínimo consumo!

*The large double glazed glasses of 22 mm of thermal insulation ensure the highest performance with the lowest consumption*

Les grandes vitres double vitrage de 22mm d'isolation, garantissent un maximum de rendement avec un minimum de consommation !

ACCESIBILIDAD TOTAL  
FULL ACCESS  
ACCESSIBILITE TOTALE

PAK nos ofrece la opción de acceder a ella por ambos lados mediante puertas correderas (cristal cámara) que no invaden el espacio útil, ideal tanto para autoservicio, como para islas independientes, encastrable en barra delantera o contra barra.

*PAK offer us the option to access from both sides through sliding double glazed window doors Suitable for self-service, to create an independent island, or to be flush-mounted on the back/front counter bar*

PAK nous offre l'option d'accéder en elle des deux côtés au moyen des portes coulissantes (verre double vitrage) qui n'envahissent pas l'espace utile, idéale aussi bien pour self-service, qu'en îlots indépendants, encastrable devant un bar ou sur un arrière bar.



OPTIMIZACIÓN TOTAL  
FULL OPTIMIZATION  
OPTIMISATION TOTALE

Increíbles estantes regulables y extraíbles de gran capacidad, con iluminación integrada sin cables! No es magia! Es PAK!

*Incredible adjustable and removable high capacity shelves with integrated wireless lighting It is not magic! It is PAK!*

Incroyables étagères réglables et retirables de grande capacité, avec illumination intégrée sans câble ! Ce n'est pas de la magie! C'est PAK !





PAK LINE

PUERTAS DE CRISTAL CÁMARA CON SISTEMA AUTOCIERRE  
**SELF-CLOSING DOUBLE GLAZED DOORS**  
 PORTES EN VERRE DOUBLE VITRAGE AVEC SYSTÈME D'AUTO FERMETURE

SUPERFICIE SUPERIOR PLANA  
**FLAT TOP**  
 SURFACE SUPERIEURE PLANE

CONSTRUIDA ÍNTEGRAMENTE CON DOBLE CRISTAL  
**ALL THE GLASSES ARE DOUBLE GLAZED**  
 TOUS LES VITRES ONT DOUBLE VITRAGE

ILUMINACIÓN RGB  
 RECLAMO LATERAL  
**LATERAL LED LIGHTING**  
 AS ADVERTISEMENT  
 LED ILLUMINATION  
 COMME RÉCLAME



OPCIÓN AUTOSERVICIO  
**SELF-SERVICE OPTION**  
 OPTION SELF-SERVICE

PROTECTOR DE TENSIÓN  
 INCORPORADO.  
**BUILT-IN VOLTAGE CHANGE**  
 PROTECTOR  
 PROTECTEUR DE TENSION  
 MAXIMUM ET MINIMUM/INTENSITÉ  
 INCORPORÉE

MEDIDAS ESTANTES REGULABLES  
**SHELVES MEASURES ADJUSTABLE**  
 DIMENSIONS ÉTAGÈRES RÉGLABLE

900x200

900x300

900x360

RUEDAS  
**WHEELS**  
 ROUE

ESPECTACULAR DISPLAY TÁCTIL DE  
 GRAN TAMAÑO Y MUY INTUITIVO  
**LARGE SIZE INTUITIVE**  
 TOUCHSCREEN  
 SPECTACULAIRE DISPLAY TACTILE DE  
 GRAND VOLUME TRÈS INTUITIF



**PAK CURVADA**

	MEDIDAS	Nº ESTANTES REGULABLES	ACCESO FRONTAL	ACCESO TRASERO	TEMP. (FOOD ZONE)	LED FRONTAL RGB	DOBLE LEDS ESTANTE
<b>PAK - CAA</b>	1015x620x1240	3	SI	SI	+4/+8°C	INCLUIDO	SI
<b>PAK - CCA</b>	1015x620x1240	3	SI	NO	+4/+8°C	INCLUIDO	SI
<b>PAK - CAC</b>	1015x620x1240	3	NO	SI	+4/+8°C	INCLUIDO	SI

PAK



PAK LINE

POSIBILIDAD DE COMBINAR ESTANTES DE CRISTAL CON ESTANTES PARA BOTELLAS  
**POSSIBILITY TO COMBINE GLASS AND BOTTLE SHELVES**  
 POSSIBILITÉ DE COMBINER LES ÉTAGÈRES EN VERRE AVEC LES ÉTAGÈRES POUR BOUTEILLES

GRAN ACCESIBILIDAD CON PUERTAS TRASERAS Y DELANTERAS  
**FRONT AND REAR DOORS HIGHLY ACCESSIBLE**  
 GRANDE ACCESSIBILITÉ PORTES DERRIÈRE ET DEVANT

PUERTAS DE CRISTAL CÁMARA CON SISTEMA AUTOCIERRE  
**DOUBLE GLAZED DOORS WITH SELF-CLOSING**  
 PORTES EN VERRE DOUBLE VITRAGE AVEC SYSTÈME D'AUTO FERMETURE

MEDIDAS ESTANTES REGULABLES  
**SHELVES MEASURES ADJUSTABLE**  
 DIMENSIONS ÉTAGÈRES RÉGLABLE

900x360

900x360

900x360

CONSTRUIDA ÍNTEGRAMENTE CON DOBLE CRISTAL  
**ALL THE GLASSES ARE DOUBLE GLAZED**  
 TOUS LES VITRES ONT DOUBLE VITRAGE



SUPERFICIE SUPERIOR PLANA  
 FLAT TOP  
 SURFACE SUPERIEURE PLANE



RECLAMO LED FRONTAL  
**FRONT LED AS ADVERTISEMENT**  
 FRONTALE LED COMME RÉCLAME

PROTECTOR DE TENSIÓN INCORPORADO.  
**BUILT-IN VOLTAGE CHANGE PROTECTOR**  
 PROTECTEUR DE TENSION MAXIMUM ET MINIMUM/INTENSITÉ INCORPORÉE

ESPECTACULAR DISPLAY TÁCTIL DE GRAN TAMAÑO Y MUY INTUITIVO  
**LARGE SIZE INTUITIVE TOUCHSCREEN**  
 SPECTACULAIRE DISPLAY TACTILE DE GRAND VOLUME TRÈS INTUITIF



**PAK RECTA**

	MEDIDAS	Nº ESTANTES REGULABLES	ACCESO PARTE DELANTERA	ACCESO PARTE TRASERA	TEMP. (FOOD ZONE)	LED FRONTAL RGB	DOBLE LEDS ESTANTE
<b>PAK - RAA</b>	1015x620x1240	3	SI	SI	+4/+8°C	INCLUIDO	SI
<b>PAK - RCA</b>	1015x620x1240	3	SI	NO	+4/+8°C	INCLUIDO	SI
<b>PAK - RAC</b>	1015x620x1240	3	NO	SI	+4/+8°C	INCLUIDO	SI

PAK



VITRINA PERFECTA PARA INTEGRAR BAJOBARRA Y TRASBARRA  
**PERFECT TO USE AS WALL AND UNDER THE COUNTER DISPLAY**  
 VITRINE PARFAITE POUR INTÉGRER SOUS UN COMPTOIR DE BAR  
 ET DERRIÈRE UN COMPTOIR DE BAR

CONSTRUIDA ÍNTEGRAMENTE CON DOBLE CRISTAL  
**ALL THE GLASSES ARE DOUBLE GLAZED**  
 TOUS LES VITRES ONT DOUBLE VITRAGE

SUPERFICIE SUPERIOR PLANA  
**TOP FLAT**  
 SURFACE SUPERIEURE PLANE

ESTANTES ILUMINADOS DE GRAN CAPACIDAD  
**ILLUMINATED SHELVES WITH HIGH CAPACITY**  
 ETAGÈRES DE GRANDE CAPACITÉ AVEC ILLUMINATION

GRAN ACCESIBILIDAD PUERTAS TRASERAS Y DELANTERAS  
**FRONT AND REAR DOORS HIGHLY ACCESSIBLE**  
 GRANDE ACCESSIBILITÉ PORTES DERRIÈRE ET DEVANT

MÁXIMO APROVECHAMIENTO DEL ESPACIO DE EXPOSICIÓN  
**OPTIMUM USE OF THE EXHIBITION AREA**  
 APPROVISIONNEMENT MÁXIMUM DANS L'ESPACE INTÉRIEUR



RECLAMO RGB LED FRONTAL  
**FRONT LED AS ADVERTISEMENT**  
 FRONTALE LED COMME RÉCLAME

PROTECTOR DE TENSIÓN INCORPORADO.  
**BUILT-IN VOLTAGE CHANGE PROTECTOR**  
 PROTECTEUR DE TENSION MAXIMUM ET MINIMUM/INTENSITÉ INCORPORÉE

ESPECTACULAR DISPLAY TÁCTIL DE GRAN TAMAÑO Y MUY INTUITIVO  
**LARGE SIZE INTUITIVE TOUCHSCREEN**  
 SPECTACULAIRE DISPLAY TACTILE DE GRAND VOLUME TRÈS INTUITIF



**COMPAK**

	MEDIDAS	Nº ESTANTES CRISTAL	ACCESO PARTE DELANTERA	ACCESO PARTE TRASERA	TEMP. (FOOD ZONE)	LED RGB FRONTAL	LEDS DOBLE ESTANTE
<b>CPAK - RAA</b>	1015x620x950	2	SI	SI	+4/+8°C	SI	SI
<b>CPAK - RAC</b>	1015x620x950	2	NO	SI	+4/+8°C	SI	SI

COMPAK LINE

COMPAK



CAPACIDAD PARA 9 BOTELLAS POR ESTANTE  
 CAPACITY FOR 9 BOTTLES IN EVERY SHELF  
 CAPACITÉ DE 9 BOUTEILLES PAR ÉTAGÈRE

SUPERFICIE SUPERIOR PLANA  
 TOP FLAT  
 SURFACE SUPÉRIEURE PLANE

ESTANTE CON ILUMINACIÓN INCORPORADA  
 COMPATIBLE CON TODOS LOS MODELOS PAK Y COMPAK  
 SHELF WITH INCLUDED LIGHTING COMPATIBLE  
 WITH ALL PAK AND COMPAK MODELS  
 ÉTAGÈRE AVEC ILLUMINATION INCORPORÉE  
 COMPATIBLE AVEC TOUS LES MODÈLES PAK ET COMPAK

DISEÑADO PARA MANTENER EN CONTACTO  
 EL VINO CON EL CORCHO DE LA BOTELLA  
 DESIGNED TO KEEP THE CONTACT OF THE WINE WITH THE  
 CORK STOPPER  
 PRÉVU POUR MAINTENIR LE CONTACT DU VIN AVEC LE  
 BOUCHON DE LIÈGE DE LA BOUTEILLE.

ESTANTES REGULABLES  
 ADJUSTABLE SHELF  
 ÉTAGÈRES RÉGLABLES

POSIBILIDAD DE COMBINAR ESTANTES DE  
 CRISTAL CON ESTANTES PARA BOTELLAS  
 POSSIBILITY TO COMBINE GLASS AND BOTTLE SHELVES  
 POSSIBILITÉ DE COMBINER LES ÉTAGÈRES EN VERRE  
 AVEC LES ÉTAGÈRES POUR BOUTEILLES

RGB CONTROL



PROTECTOR DE TENSIÓN INCORPORADO.  
 BUILT-IN VOLTAGE CHANGE PROTECTOR  
 PROTECTEUR DE TENSION  
 MAXIMUM ET MINIMUM/INTENSITÉ INCORPORÉE



ESPECTACULAR DISPLAY TÁCTIL MUY INTUITIVO DE GRAN TAMAÑO  
 LARGE SIZE INTUITIVE TOUCHSCREEN  
 SPECTACULAIRE DISPLAY TACTILE DE GRAND VOLUME TRÈS INTUITIF

COMPAK	MEDIDAS	Nº ESTANTES VINO INCLUIDOS	CAPACIDAD MAXIMA	ACCESO PARTE DELANTERA	ACCESO PARTE TRASERA	TEMP. (FOOD ZONE)	LED FRONTAL	LEDS ESTANTE
PAK-RAA-W	1015x620x1240	3	50 BOTELLAS	SI	SI	+4/+8°C	SI	SI
PAK-RCA-W	1015x620x1240	3	50 BOTELLAS	SI	NO	+4/+8°C	SI	SI
PAK-RAC-W	1015x620x1240	3	50 BOTELLAS	NO	SI	+4/+8°C	SI	SI
CPAK -RAA-W	1015x620x950	2	40 BOTELLAS	SI	SI	+4/+8°C	SI	SI
CPAK-RAC-W	1015x620x950	2	40 BOTELLAS	NO	SI	+4/+8°C	SI	SI



**SUSHI**

**PASTELERIA**

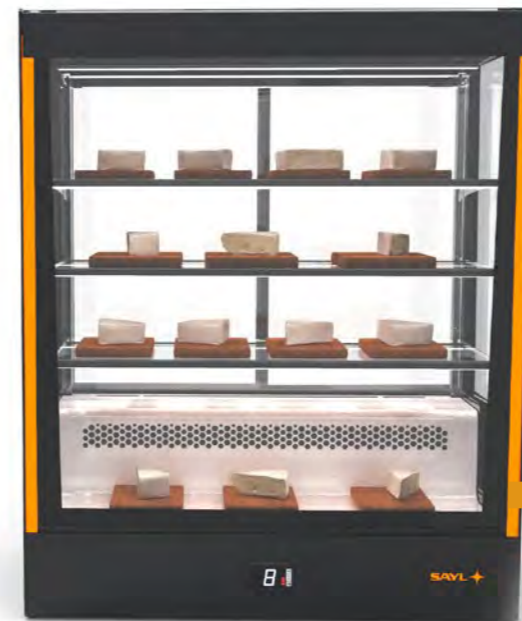

**TAKE-AWAY**

**QUESOS**



**ZUMOS**



**VINO**



**Y MUCHO MÁS...**

**VERSATILIDAD**

si tu negocio cambia, PAK cambia con él !



**TOWER LINE**

-  FAN
-  +4°C/+8°C
-  INCLUIDO
-  DESSERTS
-  SANDWICH
-  SUSHI
-  SALAD
-  BUFFET
-  FRUIT
-  DRINKS
-  SNACKS

ILUMINACIÓN INTEGRADA EN CADA ESTANTE  
 INTERIOR LIGHTING IN EVERY SHELF  
 ILLUMINATION INTÉRIEURE A CHAQUE ÉTAGE

CRISTAL SUPERIOR CÁMARA  
 DOUBLE GLAZED GLASSES  
 CHAMBRE FROIDE EN VERRE

**NEW**

CRISTAL FRONTAL CÁMARA  
 DOUBLE GLAZED GLASSES  
 CHAMBRE FROIDE EN VERRE

FABRICADAS EN ACERO INOX  
 MANUFACTURED IN STAINLESS STEEL  
 FABRIQUÉES EN ACIER INOXYDABLE

MOTOR OCULTO AL CLIENTE  
 MOTOR INVISIBLE TO THE CLIENT  
 MOTEUR INVISIBLE POUR LE CLIENT

BLANCO ÓPTICO  
 OPTICAL WHITE  
 BLANC OPTIQUE



**TWB**



**TW**

ES

Versátil vitrina refrigerada de gran capacidad de líneas rectas, ideal para sobre mostrador o empotrar con un diseño apto para los entornos más sobrios.

Dotada de 3 grandes estantes independientes de cristal, con máxima visibilidad + 2 niveles de exposición en la base.

Opcionalmente se pueden adquirir más estantes.

Potente grupo frigorífico y una sólida construcción en acero inoxidable y cristales templados

Sin necesidad de instalación.

EN

Versatile straight refrigerated display cabinet with high capacity, ideal for countertop use or to be flush mounted. Suitable for the most restrained environments.

3 large independent glass shelves with maximum visibility+ 2 exhibit levels on the base.

Optionally, you can order more shelves.

Powerful refrigerating unit and a robust structure manufactured in stainless steel and tempered glass.

No installation required.

FR

Vitrine réfrigérée versatile de grande capacité aux lignes droites, idéale pour comptoirs de bar ou dans un environnement plus sobre.

Equipée de 3 grandes étagères en verre indépendantes, maximum de visibilité + 2 niveaux d'exposition à la base.

Optionnellement on peut acquérir plus d'étagères

Groupe frigorifique puissant, solide construction en acier inoxydable et vitres en verre trempé

Sans nécessité d'installation

SIN NECESIDAD DE DESAGÜE NI INSTALACIÓN  
NO NEED OF INSTALLATION AND DRAINAGE  
PAS DE DRAINAGE OU D'INSTALLATION

ZONA DE SERVICIO  
SERVICE AREA  
ZONE DE SERVICE

ESTANTES REGULABLES  
ADJUSTABLE SHELF  
ÉTAGÈRES RÉGLABLES

ESTANTE  
(250X670mm)  
SHELF  
(250X670mm)  
ÉTAGÈRE  
(250X670mm)

ILUMINACIÓN INTERIOR EN CADA ESTANTE  
INTERIOR LIGHTING IN EVERY SHELF  
ILLUMINATION INTÉRIEURE A CHAQUE ÉTAGE

PLANO SUPERIOR 700X300  
700 X 300 FLAT TOP  
PLAN SUPÉRIEUR 700X300

CRISTALES TEMPLADOS  
TEMPERED GLASS  
VITRE EN VERRE TREMPÉ



MÁXIMO APROVECHAMIENTO DEL ESPACIO DE EXPOSICIÓN  
OPTIMUM USE OF THE EXHIBITION AREA  
APPROVISIONNEMENT MÁXIMUM DANS L'ESPACE INTÉRIEUR

**TOWER**

	MEDIDAS	ESTANTES (x3)	TEMP.	C.HUMEDAD	COLOR	LED ESTANTES
<b>TW</b>	710X535X900	695X250	+4/+8°C	NO	NEGRO	SI
<b>TWB</b>	710X535X900	695X250	+4/+8°C	NO	BLANCO	SI

SAYL

TOWER LINE

TOWER



ESPECTACULAR CONSTRUCCIÓN SIN TORNILLERÍA EXTERIOR PARA FACILITAR SU LIMPIEZA  
 SPECTACULAR CONSTRUCTION WITHOUT EXTERNAL SCREWS TO FACILITATE THE CLEANING  
 SPECTACULAIRE CONSTRUCTION SANS VISSERIE EXTERIEURE POUR FACILITER LE NETTOYAGE



ACRISTALAMIENTO COMPLETO CON VIDRIOS CÁMARA  
 ALL THE GLASSES ARE DOUBLE GLAZED  
 TOUS LES VITRES ONT DOUBLE VITRAGE

ESPACIO MOTOR OCULTO AL CLIENTE  
 MOTOR INVISIBLE TO THE CLIENT  
 MOTEUR INVISIBLE AU CLIENT

Vitrina refrigerada completamente construida con cristales cámara para evitar condensación y mantener siempre una visibilidad del producto expuesto impecable, además de conseguir un ahorro energético excelente.

Capacidad para 2 estantes regulables de cristal, con máxima visibilidad + 2 niveles de exposición en la base.

Iluminación en cada línea de exposición regulable y sin cables.

Vitrina compacta y versátil apta para conservar todo tipo de productos con una visibilidad e iluminación excepcional.

Refrigerated display entirely built with double glazed windows to avoid condensation, encourage energy saving and help you to give great visibility to your product.

Capacity for 2 adjustable glass shelves with maximum visibility and 2 display levels on the base.

Wireless lighting in every display level.

Compact and versatile display case suitable to preserve all kind of products with exceptional lighting and visibility.

Vitrine réfrigérée entièrement construite avec double vitrage pour éviter la condensation et maintenir toujours une visibilité impeccable du produit exposé, ce qui favorise en plus une excellente économie énergétique.

Capacité pour 2 étagères réglables en verre avec un maximum de visibilité + 2 niveaux d'exposition à la base.

Illuminatión sans câble à chaque ligne d'exposition réglable.

Vitrine compacte et versatile apte à conserver tous types de produits avec une visibilité et une illumination exceptionnelles.





ZONA DE SERVICIO  
SERVICE AREA  
ZONE DE SERVICE

CRISTALES TEMPLADOS  
TEMPERED GLASS  
VITRES EN VERRE TREMPÉ

TERMOSTATO ELECTRÓNICO REGULABLE "SAYL BLUE"  
"SAYL-BLUE" ADJUSTABLE ELECTRONIC THERMOSTAT  
THERMOSTAT ELECTRONIQUE RÉGLABLE "SAYL BLUE"

DISEÑO "CÓMPRAME" ENFOCADO AL CLIENTE  
"BUY ME" DESIGN FOCUSED ON THE CLIENT  
DESIGN "ACHÈTE MOI" VISANT LE CLIENT

MÁXIMA VERSATILIDAD PARA EXPONER CUALQUIER TIPO DE PRODUCTO  
MAXIMUM VERSATILITY TO EXPOSE ANY KIND OF PRODUCT  
VARIÉTÉ MAXIMALE POUR EXPOSER N'IMPORTE QUEL TYPE DE PRODUIT

PUERTAS EN CRISTAL CÁMARA  
DOUBLE GLAZED GLASS DOORS  
PORTES EN VERRE DOUBLE VITRAGE

SOBRE MOLDEADO DE UNA SOLA PIEZA  
ONE-PIECE COVER  
MOULÉ D'UNE SEULE PIÈCE



ESTANTES ILUMINADOS DE GRAN CAPACIDAD  
ILLUMINATED SHELVES WITH HIGH CAPACITY  
ÉTAGÈRES DE GRANDE CAPACITÉ AVEC ILLUMINATION

VITRINA CON MÁXIMA VISIBILIDAD  
MAXIMUM VISIBILITY DISPLAY CABINET  
VITRINE AVEC UN MAXIMUM DE VISIBILITÉ

EXTERIOR TOTALMENTE EN CRISTAL CON ACABADOS PREMIUM  
COMPLET GLASS EXTERIOR AND PREMIUM FINISHINGS  
EXTÉRIEUR COMPLET EN VERRE ET FINITIONS PREMIUM

ESTANTES REGULABLES  
ADJUSTABLE SHELF  
ÉTAGÈRES RÉGLABLES

ACCESORIO  
ACCESSORY  
ACCESSOIRE  
PGS. 178



SIN NECESIDAD DE DESAGÜE NI INSTALACIÓN  
NO NEED OF INSTALLATION AND DRAINAGE  
PAS DE DRAINAGE OU D'INSTALLATION

VELA

	MEDIDAS	ESTANTES (x2)	TEMP.	ESTANTES REGULABLES	CRISTALES CÁMARA	ILUMINACIÓN
VV	800x700x740	700x250	+2/+6°C	SI	SI	SI

SAYL

VELA LINE

VELA

65



QBO lleva la exposición a otro nivel;  
Convierte tus elaboraciones en verdaderas joyas.

*QBO brings display to a whole new level.  
It turns your products into authentic jewels.*

QBO apporte l'exposition à un niveau totalement nouveau.  
Transforme votre produit en bijoux authentiques.

QBO LINE



BASE COMPLETAMENTE RETROILUMINADA  
**BACKLIGHTED BASE**  
BASE COMPLÈTEMENT RÉTRO ILLUMINÉE

RECLAMO ASEGURADO PARA SU LOCAL  
**GREAT ADVERTISEMENT FOR YOUR BUSINESS**  
ATTRAIT ASSURÉ POUR N'IMPORTE QUEL LOCAL

**ES** Vitrina refrigerada completamente construida con cristales cámara para evitar condensación y mantener siempre la máxima visibilidad del producto expuesto, además de favorecer a un ahorro energético excelente.

Diseño de última generación de líneas rectas y angulosas con una gran apertura trasera a 90° que facilita tanto su uso como su limpieza.

Perfecta para exponer productos gourmet, tales como quesos, caviar, vino, champagne, postres, frutas exóticas, ensaladas realzando la importancia de estos.

Base completamente retro iluminada, con posibilidad de iluminación con RGB lo que la convierte en la vitrina más camaleónica jamás construida.

**EN** Refrigerated display case entirely built with double glazed windows to avoid condensation, encourage energy saving and help you to give great visibility to your product.

Latest technology angular designed in straight lines with a large 90° back opening to facilitate the use and the cleaning of the display case.

The perfect way to expose gourmet products such as cheese, caviar, champagne and exotic fruits.

Backlighted base with optional RGB what makes this display case the most chameleonic of the market.

**FR** Vitrine réfrigérée entièrement construite avec double vitrage pour éviter la condensation et maintenir toujours une visibilité impeccable du produit exposé, ce qui favorise en plus une excellente économie énergétique.

Design de dernière génération en lignes droites et anguleuses avec une grande ouverture arrière de 90° qui facilite aussi bien l'usage que le nettoyage.

Parfaite pour exposer plats cuisinés, fromages, caviar, vin, champagne, desserts, fruits, salades... et rehausser leur importance.

Base complètement rétro illuminée avec possibilité d'illumination RGB ce qui la rend caméléonique (multicolore) jamais construite.

MÁXIMA VERSATILIDAD PARA EXPONER CUALQUIER TIPO DE PRODUCTO  
**MAXIMUM VERSATILITY TO EXPOSE ANY KIND OF PRODUCT**  
 VARIÉTÉ MAXIMALE POUR EXPOSER N'IMPORTE QUEL TYPE DE PRODUIT

EXTERIOR COMPLETO EN CRISTAL CÁMARA CON ACABADOS PREMIUM  
**DOUBLE GLAZED GLASSES AND QUALITY FINISHING**  
 EXTÉRIEUR COMPLET EN DOUBLE VITRAGE ET FINITIONS PREMIUM

SIN NECESIDAD DE DESAGÜE NI INSTALACIÓN  
**NO NEED OF DRAINAGE AND INSTALLATION**  
 SANS NÉCESSITÉ DE DÉGIVRAGE NI INSTALLATION

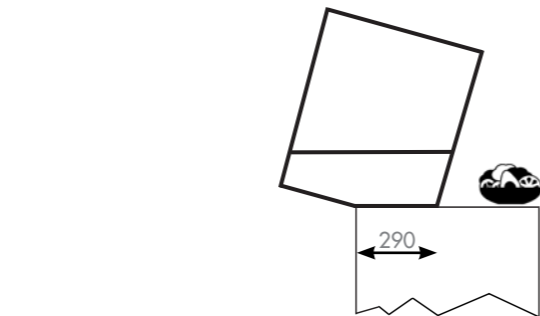

EL EFECTO LEVITANTE DE QBO, NOS PERMITE COLOCARLA EN BARRAS DE LA MANERA MÁS LLAMATIVA, CONSIGUIENDO UN ESPACIO DE TRABAJO MUY ÚTIL EN SU PARTE POSTERIOR  
**MAXIMUM VERSATILITY TO EXPOSE ANY KIND OF PRODUCT**  
 L'EFFET DE LÉVITATION DE QBO PERMET DE L'INSTALLER DE FAÇON PLUS CONSTANTE AFIN D'OBTENIR UN ESPACE DE TRAVAIL TRÈS UTILE DANS SA PARTIE ARRIÈRE

**70%**  
 EXPO  
**RECLAIM 30%**



RGB REMOTE CONTROL



AHORRO ENERGÉTICO Y GAS ECOLÓGICO  
**ENERGY SAVING AND ECOLOGIC GAS**  
 ÉCONOMIE ÉNERGÉTIQUE ET GAZ ÉCOLOGIQUE



ESPECTACULAR CONSTRUCCIÓN SIN TORNILLERÍA EXTERIOR PARA FACILITAR SU LIMPIEZA  
**SPECTACULAR CONSTRUCTION WITHOUT EXTERNAL SCREWS TO FACILITATE THE CLEANING**  
 SPECTACULAIRE CONSTRUCTION SANS VISSERIE EXTERIEURE POUR FACILITER LE NETTOYAGE



1 ESTANTE /SHELF/ ÉTAGÈRE  
 2 ESTANTES /SHELVES/ ÉTAGÈRES  
 420mm x 220mm

MÁXIMO ANGULO DE APERTURA PARA FACILITAR LA MANIPULACIÓN DE TODO TIPO DE PRODUCTOS  
**MAXIMUM OPENING ANGLE TO FACILITATE THE HANDLING OF ALL KINDS OF PRODUCTS**  
 ANGLE D'OUVRETURE MAXIMUM POUR FACILITER LA MANIPULATION DE TOUS TYPES DE PRODUITS

AMPLIA ZONA DE SERVICIO  
**WIDE SERVICE ÁREA**  
 ZONE DE SERVICE

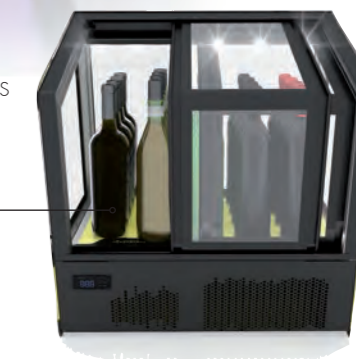

QBO

	MEDIDAS	ESTANTE	TEMP.	BASE RETROILUMINADA	RGB
QBO	620x670x670	OPCIONAL	+4/+8°C	NO	NO
QBO-L	620x670x670	OPCIONAL	+4/+8°C	SI	NO
QBO-R	620x670x670	OPCIONAL	+4/+8°C	SI	SI

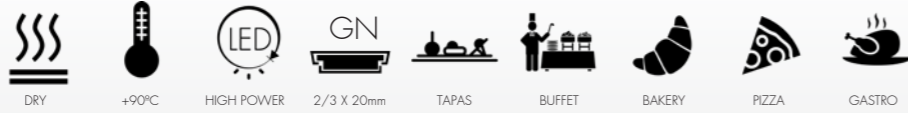

Con sus líneas sugerentes HONDA podrá elevar la temperatura de su interior para mantener sus productos calientes con una imagen exuberante.

*With its lines HONDA will raise its interior temperature to maintain the products hot with an exuberant character*

Avec ses lignes suggestives HONDA pourra élever la température de son intérieur pour maintenir ses produits chauds avec une image exubérante.

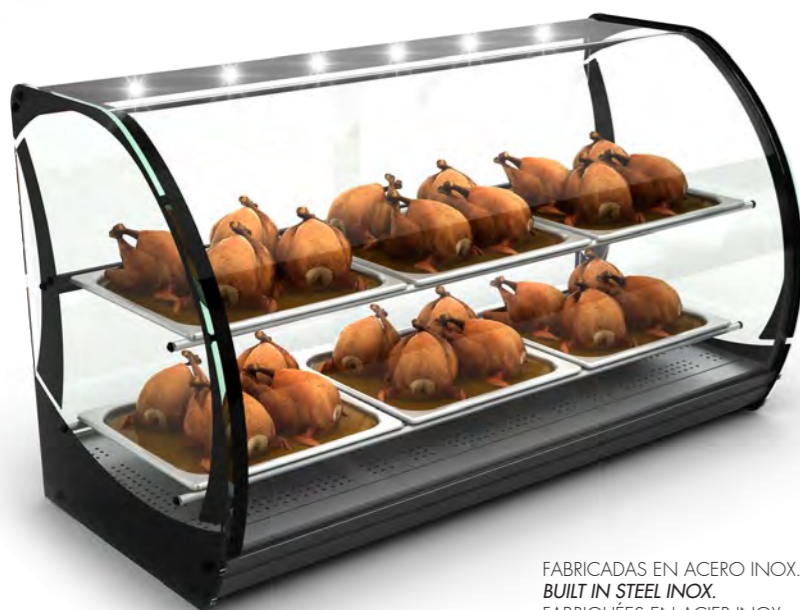

FABRICADAS EN ACERO INOX.  
BUILT IN STEEL INOX.  
FABRIQUÉES EN ACIER INOX

HIGH POWER LEDS EN LOS DOS PISOS  
HIGH POWER LEDS ON BOTH FLOORS  
LUMIÈRE LEDS AUX DEUX ÉTAGES



VISIÓN PANORÁMICA  
PANORAMIC VISION  
VISION PANORAMIQUE

INTERIOR DESMONTABLE SU LIMPIEZA  
REMOVABLE INTERIOR FOR CLEANING  
INTÉRIEUR DÉMONTABLE POUR LE NETTOYAGE

PUERTAS TRASERAS DE CRISTAL TEMPLADO  
TEMPERED GLASS REAR DOORS  
PORTES ARRIÈRE EN VERRE TREMPÉ



BANDEJAS INCLUIDAS GN 2/3 X 20  
TRAYS INCLUDED GN 2/3 X 20  
BACS INCLUS GN 2/3 X 20



CRISTAL ABATIBLE  
FOLDING GLASS  
VITRE ABATTABLE

BANDEJA DE AGUA PARA EVITAR RESECAR LOS ALIMENTOS EXPUESTOS  
TRAY WITH WATER TO PREVENT DRYING OF THE FOOD DISPLAYED  
PLATEAU A EAU AFIN D'ÉVITER LE DESSÈCHEMENT DES ALIMENTS EXPOSÉS



CRISTALES TEMPLADOS  
TEMPERATE GLASS  
VITRES EN VERRE TREMPÉ

RESISTENCIAS BLINDADAS  
ARMoured RESISTANCES  
RÉSISTANCES BLINDÉES



ACCESORIO  
ACCESSORY  
ACCESSOIRE

**HONDA**

	MEDIDA	TIPO	BANDEJAS	POTENCIA	TEMP	LED
<b>HONDA</b>	1100x510x635	CALOR SECO	6GN 2/3 x 20	1.650 W	+30 +90°C	SI
<b>HONDA-N</b>	1100x510x635	NEUTRO	6GN 2/3 x 20	50 W	NEUTRO	SI



"PARA HACER UNA TARTA DE MANZANA PRIMERO TIENES QUE CREAR UN UNIVERSO"

**CARL SAGAN** (FÍSICO-ASTRÓNOMO)

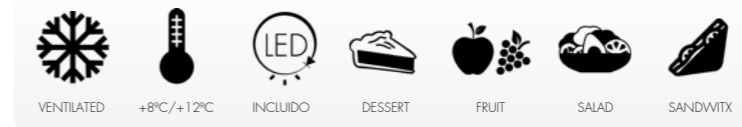

FLUJO DE AIRE SUPER LENTO PARA EVITAR RESECAR EL PRODUCTO  
 SUPER SLOW AIRFLOW TO KEEP THE PRODUCT FROM DRYING OUT  
 FLUX D'AIR SUPER LENT ÉVITANT LE DESSÈCHEMENT DU PRODUIT.

FRONTAL DE CRISTAL  
 FRONT PART MADE OF GLASS  
 DEVANTURE EN VERRE

POTENTES LEDS DE 4000K  
 POWERFUL LED LIGHTS 4000K  
 PUISSANCE DES LEDS 4000K

GRUPO MOTOR MÁS REDUCIDO  
 MORE REDUCED ENGINE SPACE  
 GROUPE MOTEUR PLUS RÉDUIT



ESTANTE DE CRISTAL EFECTO FLOTANTE  
 GLASS FLYING SHELVES  
 ÉTAGÈRE TOURNANTE EN VERRE

APERTURA DE PUERTAS DE 175° PARA FACILITAR LA LIMPIEZA Y ACCESO  
 DOOR OPENING AT 175° TO EASE CLEANING  
 OUVERTURE DES PORTES A 175° FACILITANT LE NETTOYAGE

ESTANTES REGULABLES EN ALTURA  
 ADJUSTABLE HEIGHT SHELVES  
 ÉTAGÈRES RÉGLABLES EN HAUTEUR

MEJOR CONSUMO  
 LESS ENERGY CONSUMPTION  
 CONSOMMATION MOINDRE

**DOLCE**

	MEDIDA	ESTANTES	TEMP.	ESTANTES CRISTAL	LED	PVP - ESTANTE EXTRA
<b>VD</b>	435x435x900	Ø 315	+8/+12°C	3	SI	

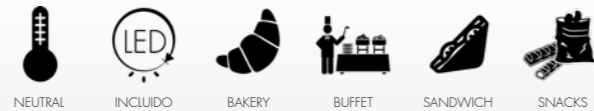

FRONTAL DE CRISTAL  
FRONT PART MADE OF GLASS  
DEVANTURE EN VERRE



POTENTES LEDS DE 4000K  
POWERFUL LED LIGHTS 4000K  
PUISSANCE DES LEDS 4000K

APERTURA DE PUERTAS DE 180°  
PARA FACILITAR LA LIMPIEZA  
DOOR OPENING AT 180°  
TO EASE CLEANING OUVERTURE  
DES PORTES A 180° FACILITANT LE  
NETTOYAGE

**EXPOSITOR DOLCE**

	MEDIDAS	ESTANTES (x4)	TEMPERATURA	LED
<b>EDL</b>	435x435x710	Ø 315	NEUTRA	SI

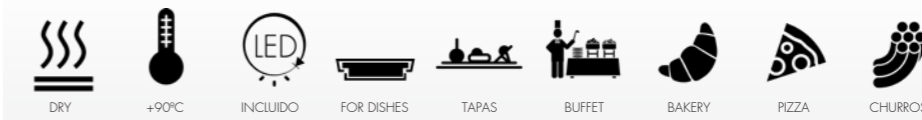

FRONTAL DE CRISTAL  
FRONT PART MADE OF GLASS  
DEVANTURE EN VERRE



POTENTES LEDS DE 4000K  
POWERFUL LED LIGHTS 4000K  
PUISSANCE DES LEDS 4000K

APERTURA DE PUERTAS DE 180°  
PARA FACILITAR LA LIMPIEZA  
DOOR OPENING AT 180°  
TO EASE CLEANING OUVERTURE  
DES PORTES A 180° FACILITANT LE  
NETTOYAGE

**CALENTADOR DOLCE**

	MEDIDAS	ESTANTES (x4)	TEMPERATURA	LED
<b>CEDL</b>	435x435x710	Ø 315	+60°C	SI

SAYL ✦



Show Must Go On !

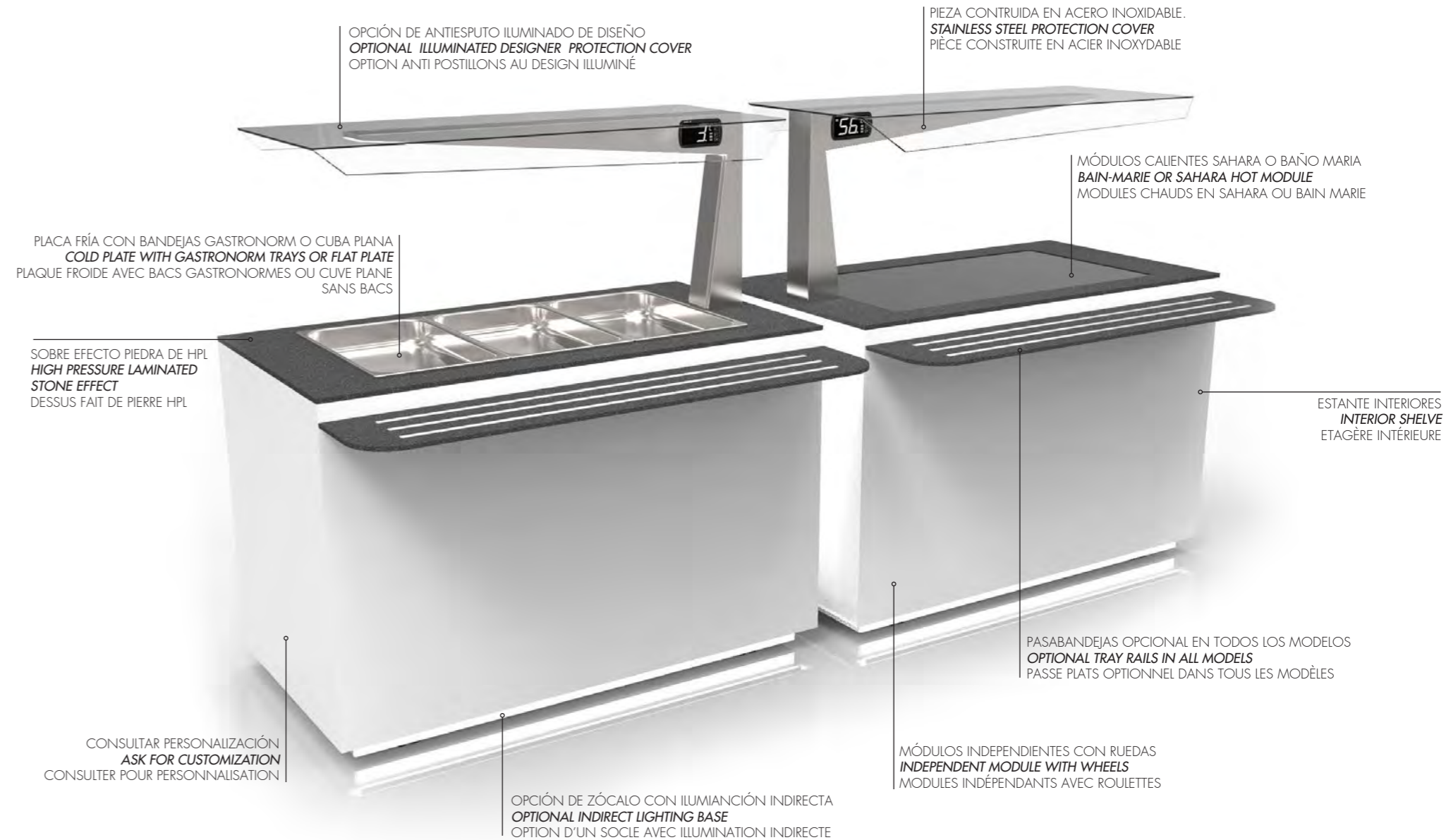
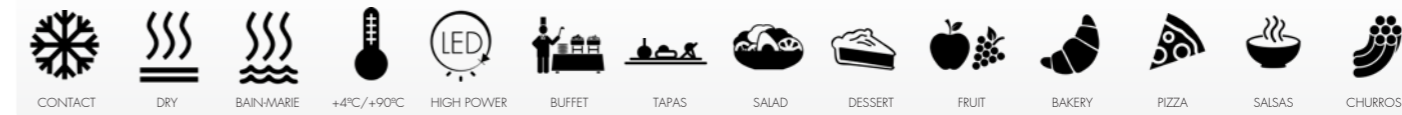

OPCIÓN DE ANTIESPUITO ILUMINADO DE DISEÑO  
 OPTIONAL ILLUMINATED DESIGNER PROTECTION COVER  
 OPTION ANTI POSTILLONS AU DESIGN ILLUMINÉ

PIEZA CONTRUIDA EN ACERO INOXIDABLE.  
 STAINLESS STEEL PROTECTION COVER  
 PIÈCE CONSTRUITE EN ACIER INOXYDABLE

MÓDULOS CALIENTES SAHARA O BAÑO MARIA  
 BAIN-MARIE OR SAHARA HOT MODULE  
 MODULES CHAUDS EN SAHARA OU BAIN MARIE

PLACA FRÍA CON BANDEJAS GASTRONORM O CUBA PLANA  
 COLD PLATE WITH GASTRONORM TRAYS OR FLAT PLATE  
 PLAQUE FROIDE AVEC BACS GASTRONORMES OU CUVE PLANE SANS BACS

SOBRE EFECTO PIEDRA DE HPL  
 HIGH PRESSURE LAMINATED  
 STONE EFFECT  
 DESSUS FAIT DE PIERRE HPL

ESTANTE INTERIORES  
 INTERIOR SHELVES  
 ETAGÈRE INTÉRIEURE

PASABANDEJAS OPCIONAL EN TODOS LOS MODELOS  
 OPTIONAL TRAY RAILS IN ALL MODELS  
 PASSE PLATS OPTIONNEL DANS TOUS LES MODÈLES

MÓDULOS INDEPENDIENTES CON RUEDAS  
 INDEPENDENT MODULE WITH WHEELS  
 MODULES INDÉPENDANTS AVEC ROULETTES

OPCIÓN DE ZÓCALO CON ILUMIANCIÓN INDIRECTA  
 OPTIONAL INDIRECT LIGHTING BASE  
 OPTION D'UN SOCLE AVEC ILLUMINATION INDIRECTE

CONSULTAR PERSONALIZACIÓN  
 ASK FOR CUSTOMIZATION  
 CONSULTER POUR PERSONNALISATION

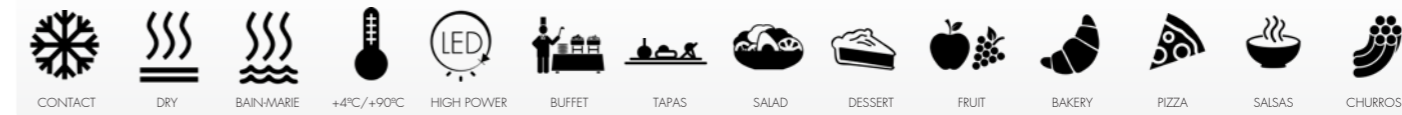

**ES** Sayl ha diseñado complementos para dar soluciones en la presentación y conservación a temperatura óptima, para pequeños cócteles, buffet y autoservicio, tanto para alimentos como en todo tipo de bebidas.

**EN** Sayl has designed accessories to provide solutions for the presentation and preservation of food & beverages for cocktails, buffets and self-service.

**FR** Sayl a dessiné des compléments pour des solutions dans la présentation et la conservation à température optimale pour petits cocktails, buffets et auto-services aussi bien pour les aliments que pour tous types de boissons.



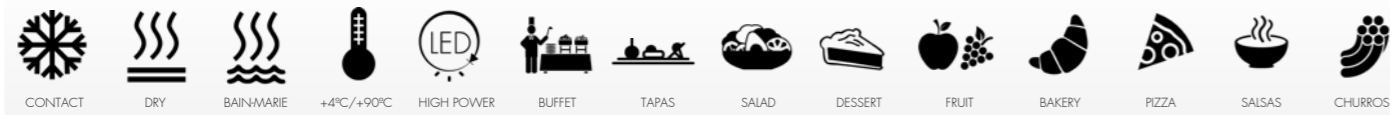

TU BUFFET, A TU GUSTO!  
 YOUR BUFFET, AT YOUR TASTE!  
 VOTRE BUFFET, A VOTRE GOÛT!

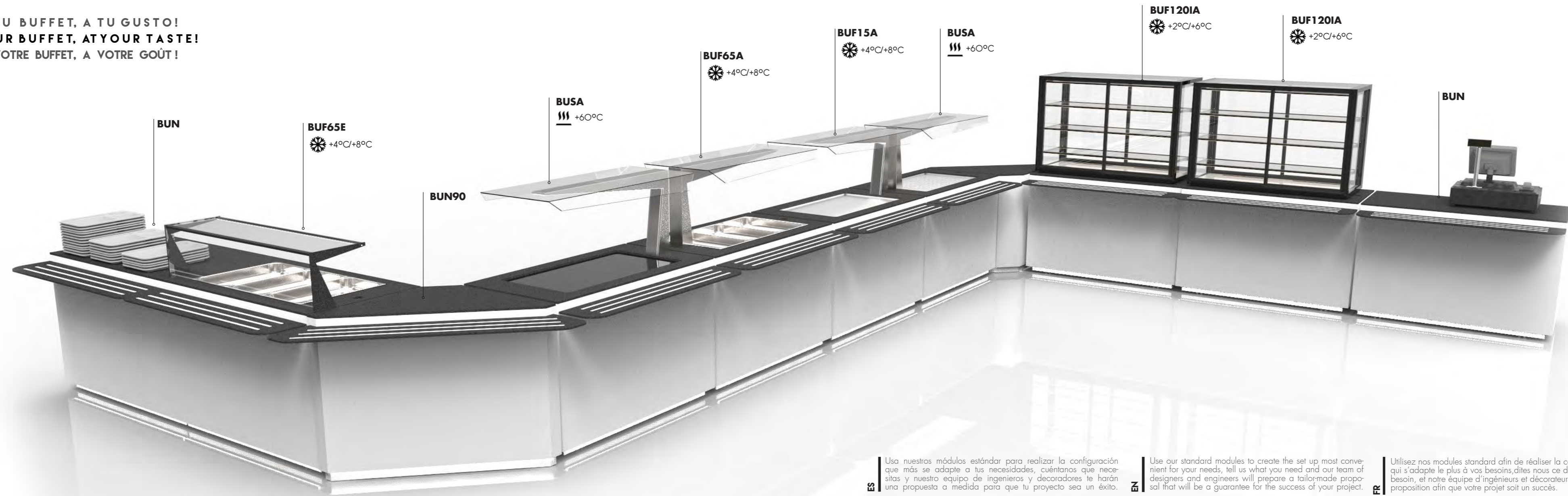

**ES** Usa nuestros módulos estándar para realizar la configuración que más se adapte a tus necesidades, cuéntanos que necesitas y nuestro equipo de ingenieros y decoradores te harán una propuesta a medida para que tu proyecto sea un éxito.

**EN** Use our standard modules to create the set up most convenient for your needs, tell us what you need and our team of designers and engineers will prepare a tailor-made proposal that will be a guarantee for the success of your project.

**FR** Utilisez nos modules standard afin de réaliser la configuration qui s'adapte le plus à vos besoins, dites nous ce dont vous avez besoin, et notre équipe d'ingénieurs et décorateurs vous fera une proposition afin que votre projet soit un succès.



**BUFFET LINE**

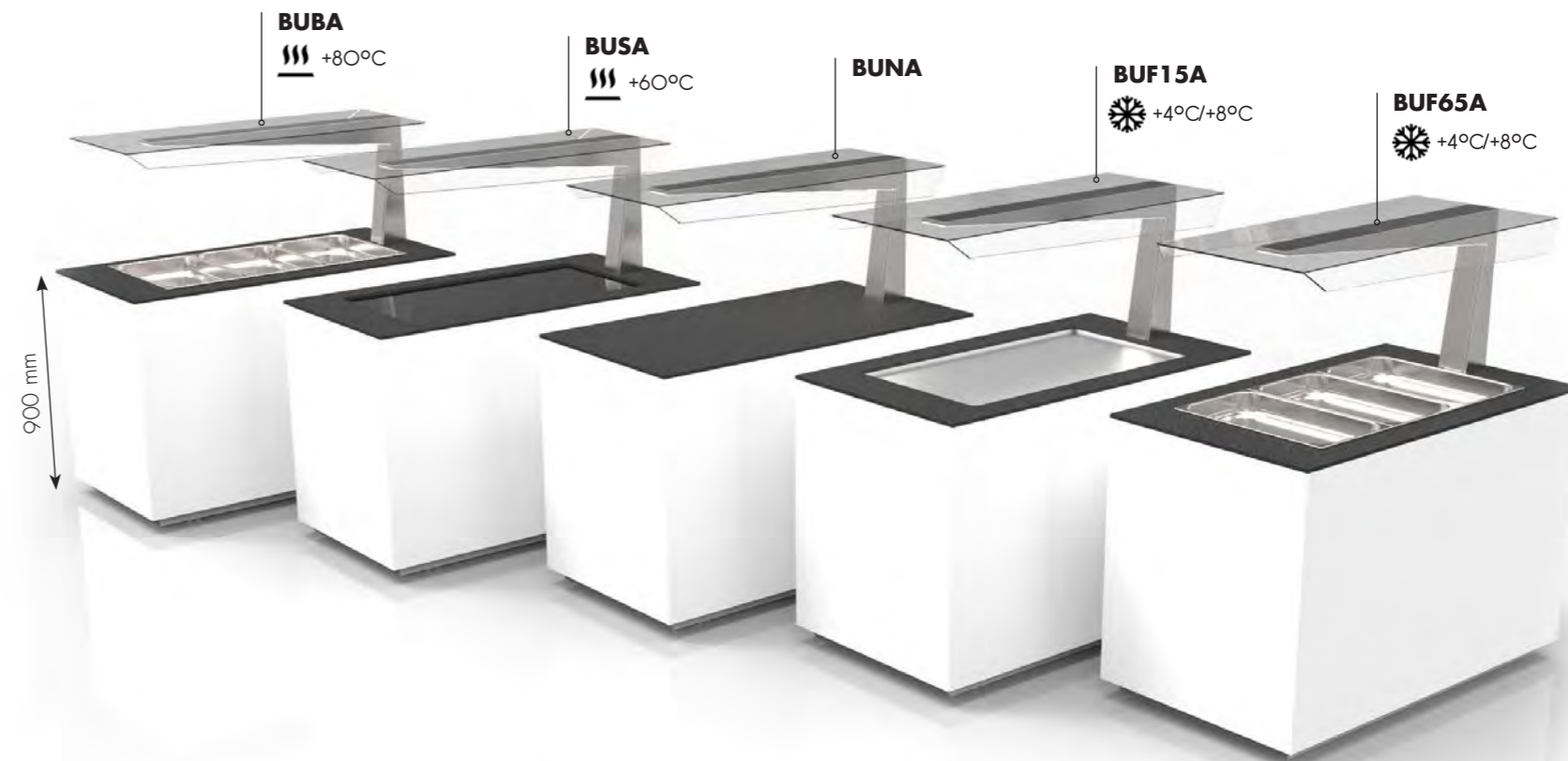
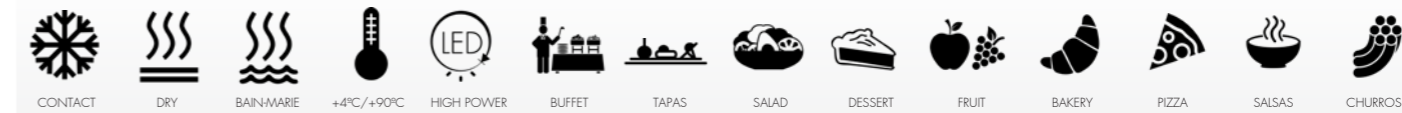

**BUFFETS CON AUTOSERVICIO**

	MEDIDAS VITRINA	TIPO	TERMOSTATO DIGITAL	ESTANTE INTERIOR	RUEDAS	TEMP. (FOOD ZONE)	BANDEJAS INCLUIDAS	LED
<b>BUF65A</b>	1300x700	PLACA FRÍA	SI	1	SI	+4/+8°C	3GN 1/1x65	SI
<b>BUF15A</b>	1300x700	PLACA FRÍA	SI	1	SI	+4°C/+8°C	NO	SI
<b>BUNA</b>	1300x700	NEUTRAL	NO	1	SI	NEUTRA	NO	SI
<b>BUSA</b>	1300x700	PLACA CALIENTE	SI	1	SI	+60°C	NO	SI
<b>BUBA</b>	1300x700	BAÑO MARIA	SI	1	SI	+80°C	3GN 1/1x65	SI

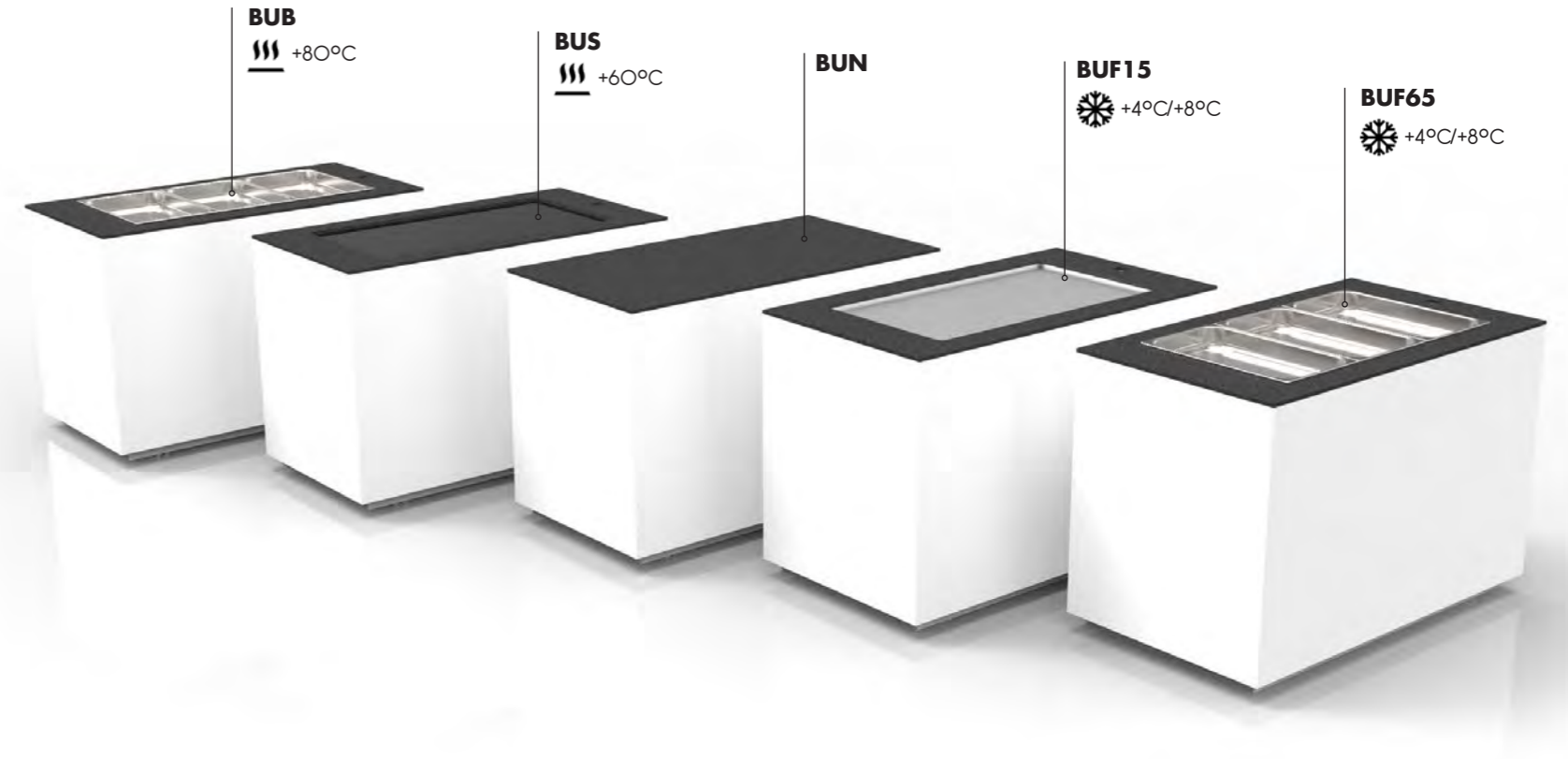
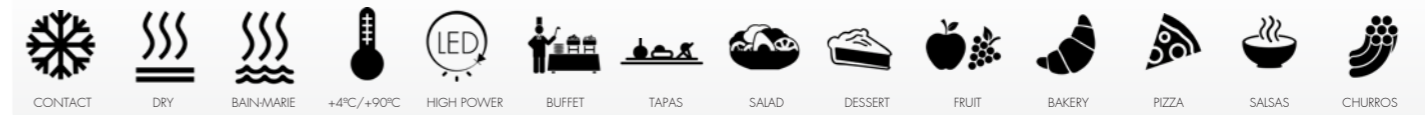
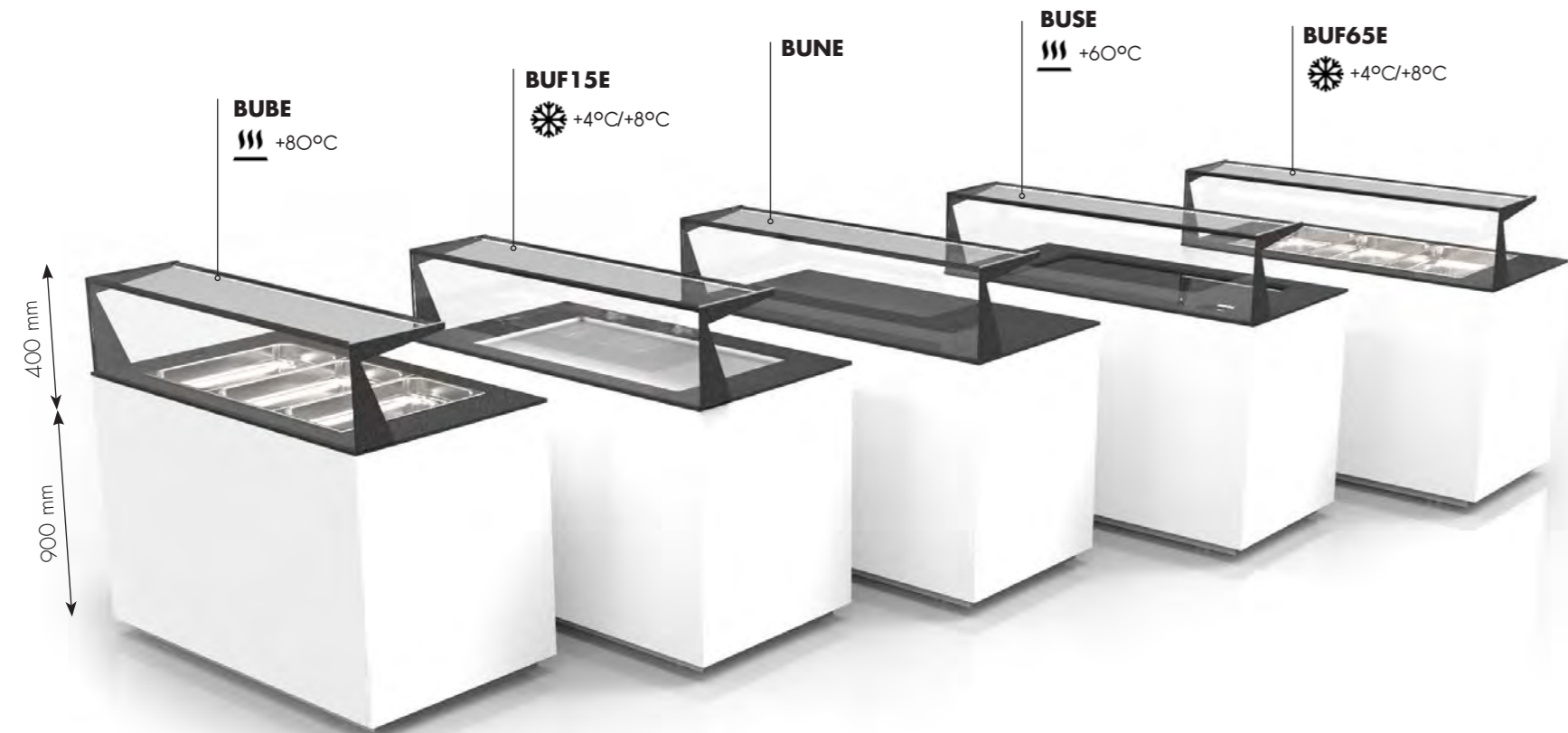
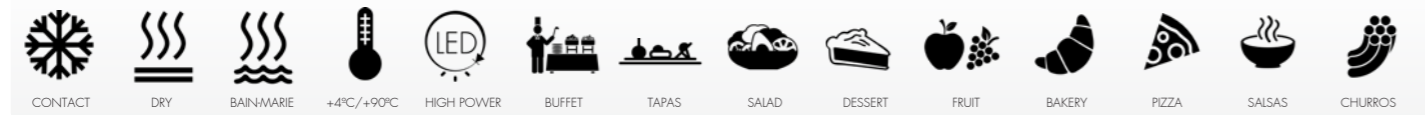

SAYL

BUFFET LINE

**BUFFETS SERVICIO**

	MEDIDAS VITRINA	TIPO	TERMOSTATO DIGITAL	ESTANTE INTERIOR	RUEDAS	TEMP. (FOOD ZONE)	BANDEJAS INCLUIDAS	LED
<b>BUF65E</b>	1300x700x1300	PLACA FRÍA	SI	1	SI	+4/+8°C	3GN 1/1x65	SI
<b>BUF15E</b>	1300x700x1300	PLACA FRÍA	SI	1	SI	+4°C/+8°C	NO	SI
<b>BUNE</b>	1300x700x1300	NEUTRAL	NO	1	SI	NEUTRA	NO	SI
<b>BUSE</b>	1300x700x1300	PLACA CALIENTE	SI	1	SI	+60°C	NO	SI
<b>BUBE</b>	1300x700x1300	BAÑO MARIA	SI	1	SI	+80°C	3GN 1/1x65	SI

**BUFFETS BASE**

	MEDIDAS VITRINA	TIPO	TERMOSTATO DIGITAL	ESTANTE INTERIOR	RUEDAS	TEMP. (FOOD ZONE)	BANDEJAS INCLUIDAS	LED
<b>BUF65</b>	1300x700x900	PLACA FRÍA	SI	1	SI	+4/+8°C	3GN 1/1x65	NO
<b>BUF15</b>	1300x700x900	PLACA FRÍA	SI	1	SI	+4°C/+8°C	NO	NO
<b>BUN</b>	1300x700x900	NEUTRAL	NO	1	SI	NEUTRA	NO	NO
<b>BUS</b>	1300x700x900	PLACA CALIENTE	SI	1	SI	+60°C	NO	NO
<b>BUB</b>	1300x700x900	BAÑO MARIA	SI	1	SI	+80°C	3GN 1/1x65	NO
<b>BUN90</b>	1300x700x900	NEUTRAL	NO	0	SI	NEUTRA	NO	NO

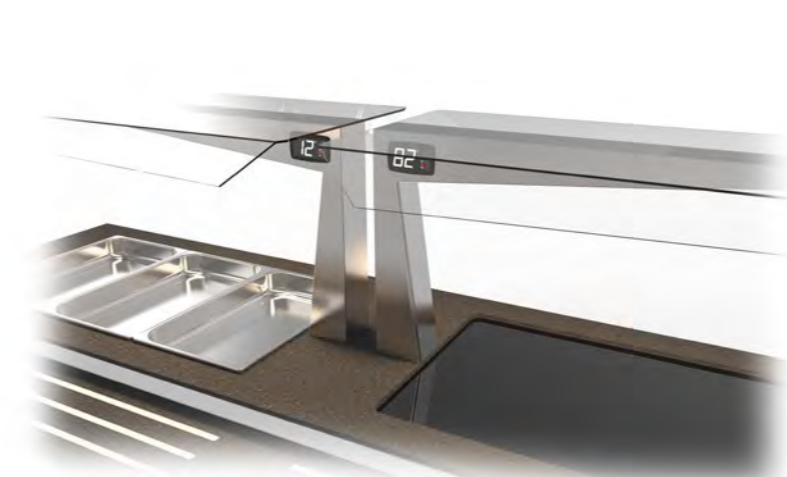
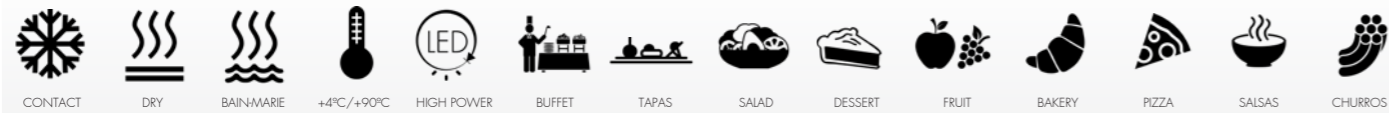

ESPECTACULAR TERMOSTATO DE GRAN TAMAÑO EN ANTIESPUTO  
**BIG SIZE THERMOSTAT ON THE PROTECTION COVER**  
 THERMOSTAT SPECTACULAIRE DE GRANDE DIMENSION ANTI-POSTILLONS



GRAN ILUMINACIÓN INTEGRADA EN ANTIESPUTO  
**GREAT LIGHTING INTEGRATED ON THE PROTECTION COVER**  
 ILLUMINATION IMPORTANTE INTÉGRÉE DANS LA PROTECTION ANTI POSTILLONS



PERFECTAMENTE COMBINABLE CON LA GAMA BUFFET 360  
**EASILY COMBINABLE WITH BUFFET 360 LINE**  
 PARFAITEMENT COMBINABLE AVEC LA GAMME BUFFET 360°



INTERIORES DE LOS BUFFETS ILUMINADOS CON ESTANTES PARA ALMACENAJE  
**BUFFET INNER PART LIGHT WITH SHELVES FOR STOCKING**  
 INTÉRIEURS DES BUFFETS AVEC ÉTAGÈRES POUR STOCKER.

**BUFFETS POSTRES**

	MEDIDAS	TIPO	TERMOSTATO DIGITAL	ESTANTE INTERIOR	RUEDAS	TEMP. (FOOD ZONE)	ESTANTES ILLUMINADOS
<b>BUF60I</b>	1300x700x1700	FRIJO VENTILADO	SI	1	SI	+4°C/+8°C	3
<b>BUF60IA</b>	1300x700x1700	FRIJO VENTILADO	SI	1	SI	+4°C/+8°C	3
<b>BUF60IG</b>	1300x700x1700	FRIJO VENTILADO	SI	1	SI	+6°C/+10°C	3
<b>BUF120I</b>	1300x700x1700	FRIJO VENTILADO	SI	1	SI	+4°C/+8°C	3
<b>BUF120IA</b>	1300x700x1700	FRIJO VENTILADO	SI	1	SI	+4°C/+8°C	3

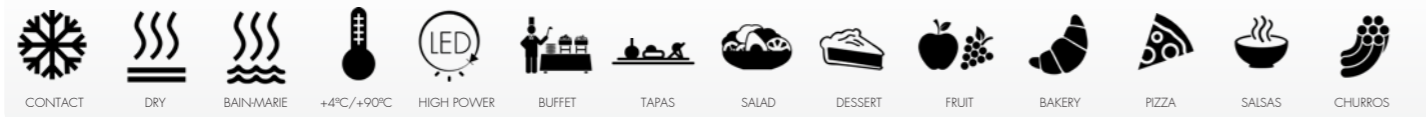

CRISTALES TEMPLADOS CERRADOS CON PASAPLATOS DE SERVICIO  
 TEMPERED GLASSES CLOSED WITH SERVICE PADS  
 LUNETTES TREMPÉES FERMÉES AVEC DES PADS DE SERVICE



TRIPLE ILUMINACIÓN  
 TRIPLE ILUMINACIÓN  
 ÉCLAIRAGE TRIPLE

OPCIONES BUFFET SERVICIO CERRADO "COVID"  
 BUFFET OPTIONS CLOSED SERVICE "COVID"  
 OPTIONS DE BUFFET SERVICE FERMÉ "COVID"



OPCIÓN DE ZÓCALO ILUMINADO PARA UNA MAYOR SENSACIÓN DE LIGEREZA.  
 OPTIONAL INDIRECT LIGHTING BASE FOR A LIGHTNESS SENSATION  
 OPTION SOCLE ILLUMINÉ POUR UNE MEILLEURE SENSATION DE LÉGÈRETÉ.

REALIZACIÓN DE PROYECTOS A MEDIDA -  
 TAILOR-MADE PROJECTS -  
 RÉALISATION DE PROJETS SUR MESURES.



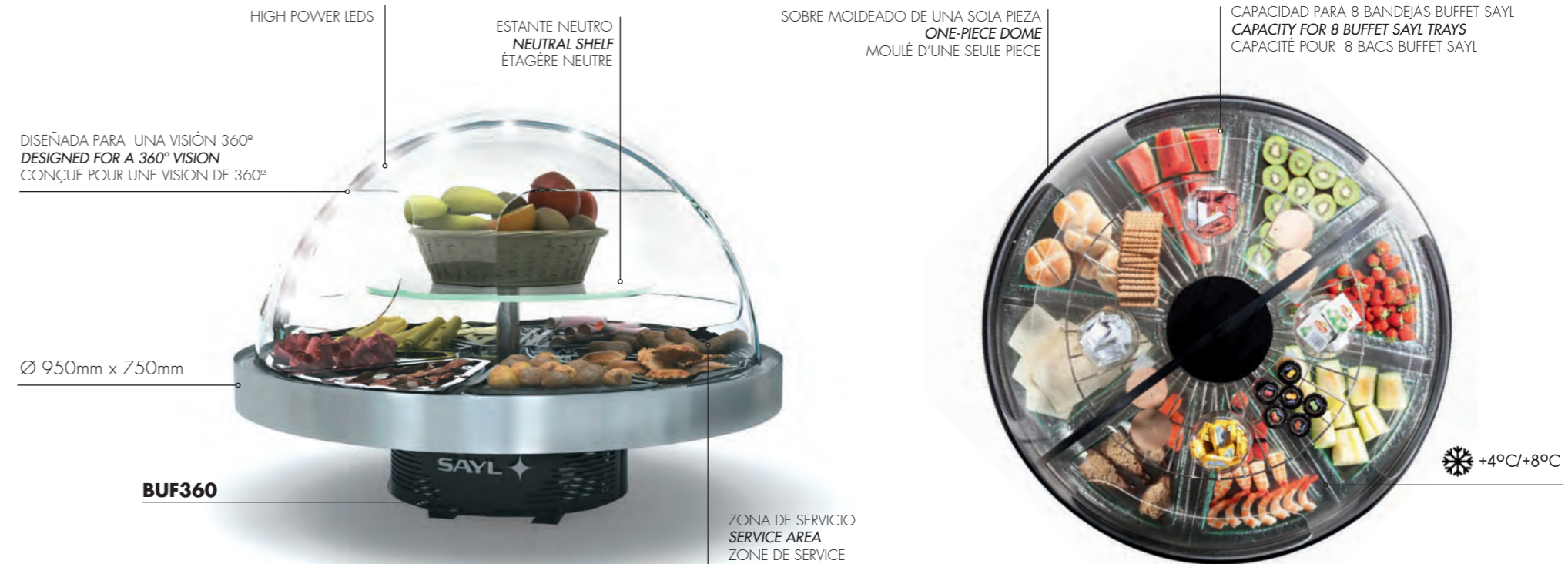

**BUF360**

**ES** Espectacular vitrina circular, especial para autoservicio en buffets. Muy versátil por sus pequeñas dimensiones, pero de gran capacidad.

Opcional : bandejas especiales diseño buffet para optimizar el espacio interior.

Construidas en acero inoxidable con desagüe incorporado.

Estante intermedio neutro para aumentar su capacidad.

Sistema de iluminación de última generación; HIGH POWER LEDS.

Modelo compacto de sobre mostrador, sin necesidad de instalación con patas regulables.

Cúpula de metacrilato fácilmente extraíble para su limpieza.

**EN** Spectacular circular display cabinet for self-service. Versatile thanks to its high capacity in a reduced size .

Optional special buffet glass design trays to optimize the interior space.

Middle neutral glass shelf to improve the capacity.

Compact models designed for countertop use no installation needed, adjustable legs.

Removable methacrylate dome for easy cleaning.

Strategically placed openings to improve the access to the food without the need to withdraw the protective dome.

**FR** Spectaculaire vitrine circulaire, spéciale pour auto-service en buffet, très versatile par ses petites dimensions mais de grande capacité.

En option bacs spéciaux design buffet pour optimiser l'espace intérieur.

Construite en acier inoxydable avec vidange incorporée.

Etagère intermédiaire neutre pour augmenter sa capacité.

Système d'illumination de dernière génération HIGH POWER LEDS.

Modèle compact de comptoirs de bar, sans nécessité d'installation, avec pieds réglables.

Coupole en méthacrylique facilement retirable pour le nettoyage.

**BUFFET 360 LINE**

**BUFFETS 360**

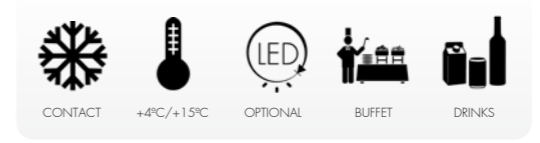

NEW

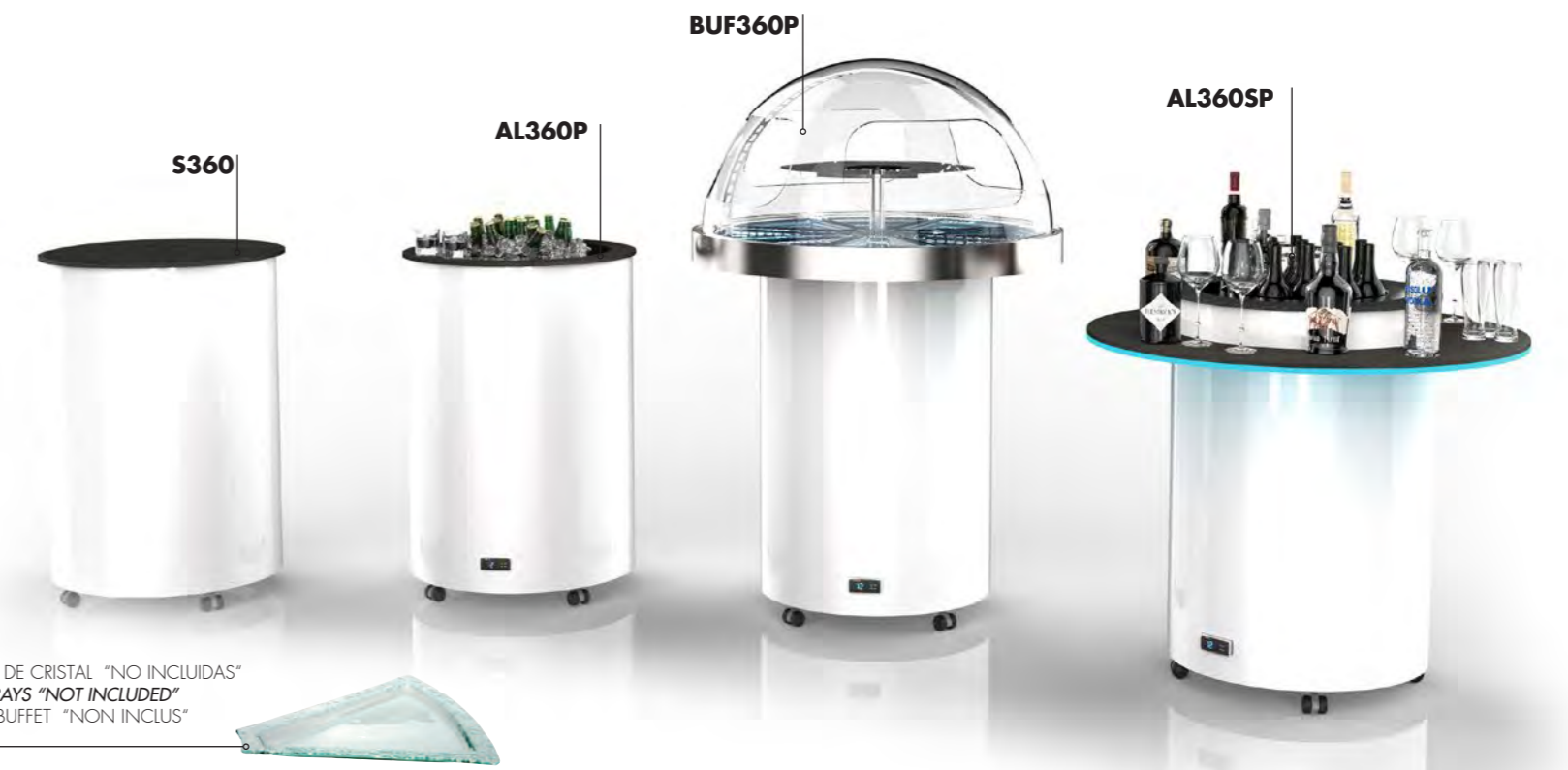

BANDEJA DISEÑO BUFFET DE CRISTAL "NO INCLUIDAS"  
 BUFFET GLASS DESIGN TRAYS "NOT INCLUDED"  
 BACS EN VERRE DESIGN BUFFET "NON INCLUS"

**BUFFETS 360**

	MEDIDAS VITRINA	BANDEJAS OPCIONALES	CUBA EMBUTIDA	ENCIMERA HPL	TERMOSTATO	PROFUNDIDAD CUBA	RUEDAS	DESAGUE	TEMP. (FOOD ZONE)	RGB
<b>S360</b>	600x600x920	NO	SI	SI	NO	NO	SI	NO	NEUTRO	NO
<b>AL360NP</b>	600x600x920	NO	SI	SI	NO	200mm	SI	SI	NEUTRO	NO
<b>AL360FP</b>	600x600x920	NO	SI	SI	SI	200mm	SI	SI	+2/+6°C	NO
<b>AL360NSP</b>	1000x600x920	NO	SI	SI	NO	200mm	SI	SI	NEUTRO	OPCIONAL
<b>AL360FSP</b>	1000x600x920	NO	SI	SI	SI	200mm	SI	SI	+2/+6°C	OPCIONAL
<b>BUF360</b>	950x950x750	8 UNIDADES	SI	NO	SI	35mm	NO	SI	+4/+8°C	NO
<b>BUF360P</b>	950x950x1350	8 UNIDADES	SI	NO	SI	35mm	SI	SI	+4/+8°C	OPCIONAL

SAYL  
**BUFFET 360 LINE**

BUFFETS 360

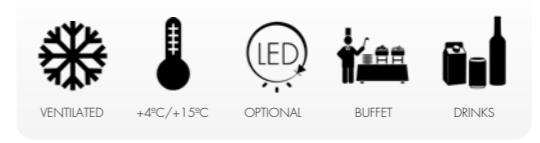

**ES** Sayl ha diseñado complementos para dar soluciones en la presentación y conservación a temperatura óptima, para pequeños cócteles, buffet y autoservicio, tanto en alimentos como en todo tipo de bebidas.

**EN** Sayl has designed accessories to provide solutions for the presentation and preservation of food & beverages for cocktails, buffets and self-service.

**FR** Sayl a dessiné des compléments pour des solutions dans la présentation et la conservation à température optimale pour petits cocktails, buffets et auto-services aussi bien pour les aliments que pour tous types de boissons.



DESEÑADA PARA UNA VISIÓN 360° DE LAS BOTELLAS  
DESIGNED FOR A 360° VISION OF THE BOTTLES  
CONÇUE POUR UNE VISION DES BOUTEILLES A 360°



"SAYL BLUE" DIGITAL CONTROL



POSIBILIDAD DE ILUMINACIÓN CON LED  
POSSIBILITY OF LED LIGHTING  
POSSIBILITÉ ÉCLAIRAGE LED

**ES** Capacidad para 8 botellas. MEDIDAS : 435x435x370mm  
Espectacular y atractivo diseño que dan prestigio y elegancia a su establecimiento.  
Posibilidad de iluminación con LEDs.  
Gran visibilidad de la marca del producto expuesto con visión de 360° lo que lo convierte en un magnífico reclamo publicitario.

**EN** Capacity for 8 bottles. Measures : 435 x 435 x 370 mm  
Spectacular and attractive design that gives prestige and elegance to your establishment.  
Possibility of LED lighting.  
Great visibility of the product brand thanks to the 360° vision what makes it a commercial claim .

**FR** Capacité pour 8 bouteilles DIMENSIONS 435x435x370mm  
Design spectaculaire et attractif ce qui donne prestige et élégance à votre établissement  
Possibilité éclairage LEDs  
Grande visibilité de la marque du produit exposé avec une vision de 360° offrant une magnifique publicité

**VITRINA ALEGRIA**

	MEDIDAS	CAPACIDAD	TEMP. (FOOD ZONE)	LED
<b>AL</b>	435x435x370	8BOTELLAS 90mm	+7/+1.5°C	NO
<b>ALL</b>	435x435x370	8BOTELLAS 90mm	+7/+1.5°C	SI



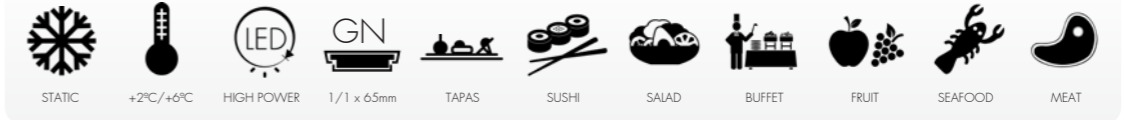

AHORA CON GUÍAS DE ACERO  
NOW WITH STEEL GUIDES  
MAINTENANT AVEC DES GUIDES EN ACIER

PLACA FRÍA Y EVAPORADOR ESTÁTICO  
COLD TRAY AND STATIC EVAPORATOR  
PLAQUE FROIDE ET EVAPORATEUR STATIQUE

HIGH POWER LEDS

CRISTAL CORREDERO  
SLIDING GLASS  
VITRE COULISSANTE



ESPACIO MOTOR OCULTO AL CUENTE  
MOTOR INVISIBLE TO THE CLIENT  
MOTEUR INVISIBLE AU CLIENT

FABRICADAS EN ACERO INOX. AISI 316  
MANUFACTURED IN AISI 316 STAINLESS STEEL  
FABRIQUÉES EN ACIER INOX AISI316

CRISTALES TEMPLADOS  
TEMPERED GLASS  
VITRES EN VERRE TREMPÉ

VISIÓN PANORÁMICA  
PANORAMIC VISION  
VISION PANORAMIQUE

SAYL  
XL  
LINE

DISPONIBLE EN 3 COLORES  
AVAILABLE IN 3 COLORS  
DISPONIBLE EN 3 COLORIS



VX3S

DOBLE ZONA DE SERVICIO  
DOUBLE SERVICE AREA  
DOUBLE ZONE DE SERVICE



CARRO ACERO INOX

BANCO DE TRABAJO PLANO DE ACERO  
FLAT STAINLESS STEEL WORKBENCH  
PLAN DE TRAVAIL EN ACIER

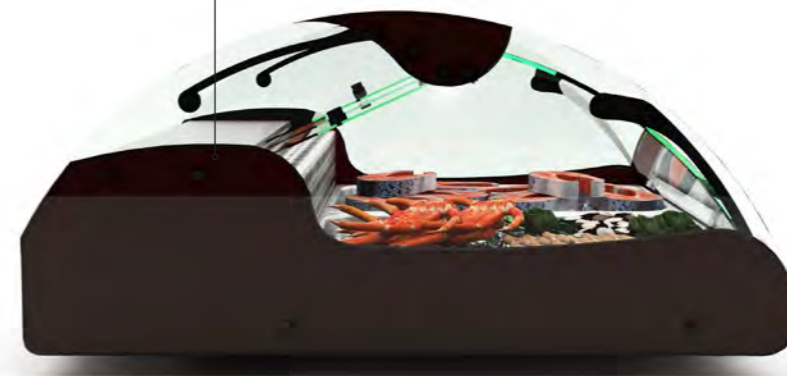

ACERO ESPECIAL PARA PESCADO  
SPECIAL STEEL FOR FISH  
ACIER SPÉCIAL POISSONS



VX2S

DISPONIBLE EN 2 TAMAÑOS (2GN 1/1 Y 3GN 1/1)  
AVAILABLE IN 2 GN 1/1 AND 3 GN 1/1  
DISPONIBLE EN 2 DIMENSIONS (2GN 1/1 ET 3GN 1/1)



ACCESORIO  
ACCESSORY  
ACCESSOIRE  
PGS. 185



"SAYL BLUE" DIGITAL CONTROL

Vitrina refrigerada de doble acceso para la exposición de pescados, ensaladas, postres y alimentos frescos en general.

Equipada con placa fría + evaporador estático para garantizar el frío en toda la "food zone" sin reseca el producto.

Modelos especiales contruidos en acero inoxidable AISI316 para ambientes salinos (pescados, mariscos...)

ES Sin necesidad de instalación

Double access refrigerated display cabinet for the exhibition of fish, salads, desserts and fresh food in general

Equipped with a cold tray and a static evaporator to ensure coolness at the "food zone" without making the product dry

Special models manufactured in AISI 316 stainless steel appropriate for saline environments

EN No need of installation

Vitrine réfrigérée à double accès pour l'exposition de poissons, salades, desserts et aliments frais en général.

Equipée d'une plaque froide + évaporateur statique garantissant le froid dans toute la zone des aliments sans assécher le produit.

Modèles spéciaux construits en acier inoxydable AISI316 pour ambiances salées (poissons, crustacés)

FR Sans nécessité d'installation

XL

	MEDIDAS	ACERO	TEMP. (FOOD ZONE)	COLORES	BANDEJA	POWER LED
<b>VX2S</b>	680x882x400	AISI 316	+2 / +6 °C		2 GN 1/1x65	SI
<b>VX3S</b>	1000x882x400	AISI 316	+2 / +6 °C		3 GN 1/1x65	SI

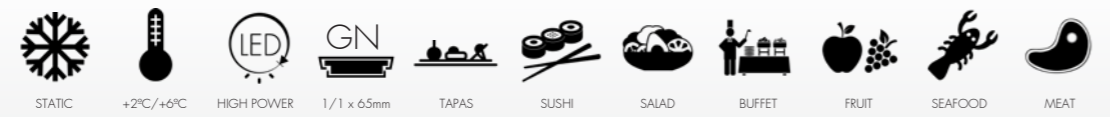

CRISTAL CORREDERO  
SLIDING GLASS  
COULISSANTE EN VERRE

HIGH POWER LEDS

ESTANTE INTERMEDIO DE CRISTAL  
MIDDLE GLASS SHELF  
ÉTAGÈRE INTERMÉDIAIRE EN VERRE

PLANO SUPERIOR  
TOP FLAT  
PLAN SUPÉRIEUR

ROBUSTA GUÍA DE ACERO INOX.  
SOLID STAINLESS STEEL GUIDE  
GLISSIÈRE ROBUSTE EN ACIER INOXYDABLE



FABRICADAS EN ACERO INOX. AISI 316  
MANUFACTURED IN AISI 316 STAINLESS STEEL  
FABRIQUÉES EN ACIER INOX. AISI 316

ACERO ESPECIAL PARA PESCADO  
SPECIAL STEEL FOR FISH  
ACIER SPÉCIAL POISSONS

CRISTALES TEMPLADOS  
TEMPERED GLASS  
VITRES EN VERRE TREMPÉ

PLACA FRÍA Y EVAPORADOR ESTÁTICO  
COLD TRAY AND STATIC EVAPORATOR  
PLAQUE FROIDE ET ÉVAPORATEUR STATIQUE



ACCESORIO  
ACCESSORY  
ACCESSOIRE  
PGS. 185

ESPACIO MOTOR OCULTO AL CLIENTE  
MOTOR INVISIBLE TO THE CLIENT  
MOTEUR INVISIBLE AU CLIENT

3 BANDEJAS INCLUIDAS GN 1/1 X 65  
3 GN 1/1 X 65 TRAYS INCLUDED  
3 BACS INCLUS GN 1/1 X 65

2 BANDEJAS INCLUIDAS GN 1/1 X 65  
2 GN 1/1 X 65 TRAYS INCLUDED  
2 BACS INCLUS GN 1/1 X 65

TERMOSTATO ELECTRÓNICO REGULABLE  
ADJUSTABLE ELECTRONIC THERMOSTAT  
THERMOSTAT ELECTRONIQUE REGLABLE

ESTANTE - 990 X195mm



BLK3

ESTANTE - 670 X195mm



BLK2

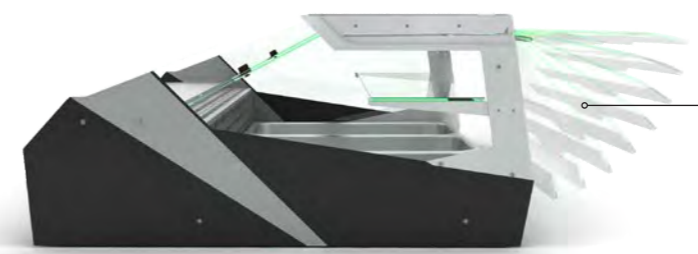

CRISTAL DELANTERO ABATIBLE Y OCULTABLE, DEJANDO LA VITRINA COMPLETAMENTE ABIERTA  
FOLDING AND CONCEALABLE FRONT GLASS THAT LEAVES THE DISPLAY CABINET COMPLETELY OPENED  
VITRE AVANT ABATTABLE ET OCCULTABLE LAISSANT LA VITRINE COMPLÈTEMENT OUVERTE

**BLOCK**

	MEDIDAS	ACERO	TEMP. (FOOD ZONE)	BANDEJA	POWER LED
<b>BLK2</b>	680x882x400	AISI 316	+2 /+6 °C	2 GN 1/1x65	SI
<b>BLK3</b>	1000x882x400	AISI 316	+2 /+6 °C	3 GN 1/1x65	SI



ES

Modelos con apertura delantera y trasera, ideales para autoservicio o doble servicio.

Vitrinas de gran capacidad para bandejas gastronómicas GN1/1x65mm

Opción de estante superior para aumentar su capacidad.

Construidas en acero inoxidable y cristales templados.

Sistema de iluminación de última generación HIGH POWER LEDS.

Modelos compactos de sobremostrador, sin necesidad de instalación y con patas regulables.

Desagüe incorporado para facilitar su limpieza.

EN

Models with front and back opening, ideal for self-service or double service.

Three large capacity models for GN 1/6x65 trays

Optional top shelf to increase capacity

Manufactured in stainless steel and tempered glass

Latest technology HIGH POWER LEDS lighting system

Compact models designed for countertop use ( no need of installation) , adjustable legs

Easy cleaning drainage

FR

Vitrine réfrigérée à double accès pour l'exposition de poissons, salades, desserts et aliments frais en général.

Trois modèles de grande capacité pour plateaux gastronomiques GN1/1-65mm

Construit en acier inoxydable et verre trempé.

Étage du milieu du verre trempé pour la capacité accrue.

Système d'éclairage de dernière génération HIGH POWER LEDS.

Modèles de comptoir compacts, sans installation, avec pieds réglables

Construit avec vidange pour un nettoyage facile.



90°C

90°C

+2°C/+6°C

650mm



**AVMX2 - AVMX3**  
 OPCIONAL: ESTANTE CRISTAL SUPERIOR  
 OPTIONAL: TOP GLASS SHELF  
 OPTION: TOP PLATEAU EN VERRE



ESPACIO MOTOR "MINI"  
 "MINI" SPACE MOTOR  
 ESPACE MOTEUR "MINI"

ACERO ESPECIAL PARA PESCADO  
 SPECIAL STEEL FOR FISH  
 ACIER SPÉCIAL POISSONS

PUERTA DELANTERA PARA AUTOSERVICIO  
 FRONT DOOR FOR SELF-SERVICE  
 PORTA AVANT POUR L'AUTO

HIGH POWER LEDS

CRISTALES TEMPLADOS  
 TEMPERED GLASS  
 VITRES EN VERRE TREMPÉ

FABRICADAS EN ACERO AISI 316  
 MANUFACTURED IN AISI 316 STAINLESS STEEL  
 FABRIQUÉ EN ACIER INOX AISI316



AHORA CON GUIAS DE ACERO  
 NOW WITH STEEL GUIDES  
 MAINTENANT AVEC DES GUIDES EN ACIER



"SAYL BLUE"  
 DIGITAL CONTROL

BANDEJAS INCLUIDAS GN 1/1 X 65  
 GN 1/1 X 65 TRAYS INCLUDED  
 PLATEAU INCLUS GN 1/1 X 65



ZONA DE SERVICIO  
 SERVICE AREA  
 ZONE DE SERVICE



ACCESORIO  
 ACCESSORY  
 ACCESSOIRE  
 PGS. 185

**MAXISELF TAPAS**

	MEDIDAS	ACCESORIO ESTANTE	BANDEJA	TEMP. (FOOD ZONE)	LED
<b>VMX2</b>	880x650x320	NO	2 GN 1/1x65	+2°C / +6°C	SI
<b>VMX3</b>	1210x650x320	NO	3 GN 1/1x65	+2°C / +6°C	SI
<b>VMX2E</b>	880x650x320	SI	2 GN 1/1x65	+2°C / +6°C	SI
<b>VMX3E</b>	1210x650x320	SI	3 GN 1/1x65	+2°C / +6°C	SI

MODELOS DISPONIBLES EN CUBA PLANA - .MODELS ALSO AVAILABLE IN FLAT VAT - MODÈLES DISPONIBLES EN CUVE PLANE (SANS BAC)

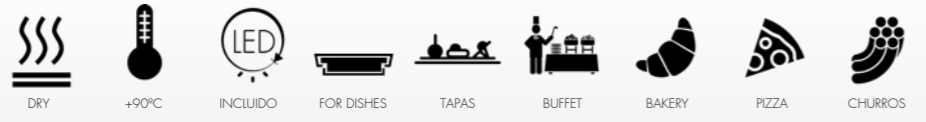

**ACMX2 - ACMX3**  
 OPCIONAL: ESTANTE CRISTAL SUPERIOR  
 OPTIONAL: TOP GLASS SHELF  
 OPTION: TOP PLATEAU EN VERRE



CRISTALES TEMPLADOS  
 TEMPERED GLASS  
 TEMPÉRÉE VERRE

FABRICADAS EN ACERO AISI 304  
 MANUFACTURED IN AISI 304 STAINLESS STEEL  
 FABRIQUÉ EN ACIER INOX AISI 304

PUERTA DELANTERA PARA AUTOSERVICIO  
 FRONT DOOR FOR SELF-SERVICE  
 PORTA AVANT POUR L'AUTO



INTERIOR DESMONTABLE PARA LIMPIEZA  
 REMOVABLE INTERIOR FOR EASY CLEANING  
 NETTOYAGE INÉRIEUR DÉMONTABLE



BANDEJAS INCLUIDAS GN 1/1 X 65  
 GN 1/6 X 65 TRAYS INCLUDED  
 PLATEAU INCLUS GN 1/1 X 65



PUERTA DELANTERA PARA AUTOSERVICIO  
 FRONT DOOR FOR SELF-SERVICE  
 PORTA AVANT POUR L'AUTO

INTERIOR DESMONTABLE PARA LIMPIEZA  
 REMOVABLE INTERIOR FOR EASY CLEANING  
 NETTOYAGE INÉRIEUR DÉMONTABLE



ACCESORIO  
 ACCESSORY  
 ACCESSOIRE  
 PGS.185



**ACMX2 - ACMX3**  
 OPCIONAL: ESTANTE CRISTAL SUPERIOR  
 OPTIONAL: TOP GLASS SHELF  
 OPTION: TOP PLATEAU EN VERRE



FABRICADAS EN ACERO AISI 304  
 MANUFACTURED IN AISI 304 STAINLESS STEEL  
 FABRIQUÉ EN ACIER INOX AISI 304

**MAXISELF SAHARA**

	MEDIDAS	ACCESORIO ESTANTE	POTENCIA	TEMP.	LED
<b>CSMX2</b>	690x650x320	NO	1.210W	90°C	SI
<b>CSMX3</b>	1020x650x320	NO	1.210W	90°C	SI
<b>CSMX2E</b>	690x650x320	SI	1.210W	90°C	SI
<b>CSMX3E</b>	1020x650x320	SI	1.210W	90°C	SI

**MAXISELF BAÑO MARIA**

	MEDIDAS	ACCESORIO ESTANTE	BANDEJAS	POTENCIA	TEMP.	LED
<b>CMX2</b>	690x650x320	NO	2 GN 1/1x65	1.210W	90°C	SI
<b>CMX3</b>	1020x650x320	NO	3 GN 1/1x65	1.210W	90°C	SI
<b>CMX2E</b>	690x650x320	SI	2 GN 1/1 x65	1.210W	90°C	SI
<b>CMX3E</b>	1020x650x320	SI	3 GN 1/1 1x65	1.210W	90°C	SI

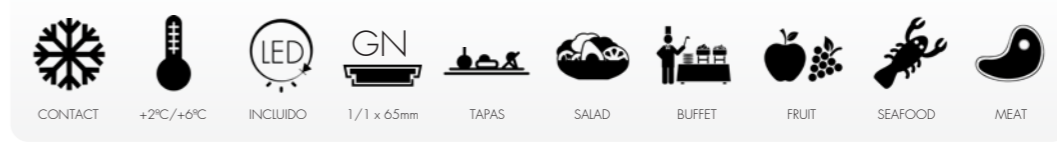

90°C

90°C

+2°C/+6°C

650mm

ACERO ESPECIAL PARA PESCADO  
SPECIAL STEEL FOR FISH  
ACIER SPÉCIAL POISSONS



HIGH POWER LEDS

ESPACIO MOTOR "MINI"  
"MINI" SPACE MOTOR  
ESPACE MOTEUR "MINI"

SAYL BLUE" DIGITAL CONTROL

+2°C/+6°C

BANDEJAS INCLUIDAS GN 1/1 X 65  
GN 1/6 X 65 TRAYS INCLUDED  
BACS INCLUS GN 1/1 X 65

FABRICADAS EN ACERO AISI 316  
MANUFACTURED IN AISI 316 STAINLESS STEEL  
FABRIQUÉES EN ACIER INOX AISI 316

CRISTAL ABATIBLE  
FOLDING GLASS  
VITRE ABATTABLE



ZONA DE SERVICIO  
SERVICE AREA  
ZONE DE SERVICE

**SPLENDID TAPAS**

	MEDIDAS	ESTANTE NEUTRO	BANDEJA	TEMP. (FOOD ZONE)	LED
<b>VS2</b>	880x650x420	600x195	2 GN 1/1x65	+2/+6 °C	SI
<b>VS3</b>	1210x650x420	1000x195	3 GN 1/1x65	+2/+6 °C	SI

MODELOS DISPONIBLES EN CUBA PLANA - AVAILABLE ALSO IN FLAT PLATE MODELS - MODÈLES DISPONIBLES EN CUVE PLANE (SANS BAC)

SAYL  
LINE  
SPLENDID

**ES** Seis modelos de gran capacidad para bandejas gastronorm GN1/1x65mm  
Construidas en acero inoxidable y cristales templados.  
Estante intermedio de cristal templado para aumentar su capacidad.  
Sistema de iluminación de última generación HIGH POWER LEDS.  
Modelos compactos de sobremostrador, sin necesidad de instalación y con patas regulables.  
Desagüe incorporado para facilitar la limpieza.

**EN** Six large capacity models for GN 1/6x65 trays.  
Manufactured in stainless steel and tempered glass.  
Middle tempered glass shelf designed to improve capacity  
Latest technology high power leds lighting system  
Compact models designed for countertop use no need of installation, adjustable legs  
Easy cleaning drainage

**FR** Six modèles de grande capacité pour bacs gastronorm GN1/1-65mm.  
Construites en acier inoxydable et vitres en verre trempé.  
Étagère intermédiaire en verre trempé pour augmenter sa capacité.  
Système d'illumination de dernière génération  
Modèles compacts de comptoirs de bars sans nécessité d'installation  
Vidange incorporée facilitant le nettoyage.

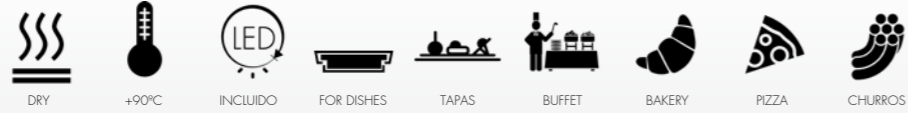

CRISTAL ABATIBLE  
FOLDING GLASS  
PLIANTE VERRE

INTERIOR DESMONTABLE PARA SU LIMPIEZA  
REMOVABLE INTERIOR FOR EASY CLEANING  
NETTOYAGE INÉRIEUR DÉMONTABLE



90°C



DIGITAL CONTROL

FABRICADAS EN ACERO AISI 304  
MANUFACTURED IN AISI 304 STAINLESS STEEL  
FABRIQUÉ EN ACIER INOX AISI 304



HIGH POWER LEDS

CRISTAL ABATIBLE  
FOLDING GLASS  
PLIANTE VERRE

INTERIOR DESMONTABLE PARA SU LIMPIEZA  
REMOVABLE INTERIOR FOR EASY CLEANING  
NETTOYAGE INÉRIEUR DÉMONTABLE



90°C



DIGITAL CONTROL

FABRICADAS EN ACERO AISI 304  
MANUFACTURED IN AISI 304 STAINLESS STEEL  
FABRIQUÉ EN ACIER INOX AISI 304



BANDEJAS INCLUIDAS GN 1/1 X 65  
GN 1/1 X 65 TRAYS INCLUDED  
PLATEAU INCLUS GN 1/1 X 65

SAYL  
LINE  
SPLENDID

**SPLENDID SAHARA**

	MEDIDAS	ESTANTE	BANDEJAS	POTENCIA	TEMP.	LED
<b>CS2S</b>	690x650x420	670x195	2 GN 1/1x65	1.210W	90°C	SI
<b>CS3S</b>	1020x650x420	1000x195	3 GN 1/1x65	1.210W	90°C	SI

**SPLENDID BAÑO MARIA**

	MEDIDAS	ESTANTE	BANDEJAS	POTENCIA	TEMP.	LED
<b>CS2</b>	690x650x420	670x195	2 GN 1/1x65	1.210W	90°C	SI
<b>CS3</b>	1020x650x420	1000x195	3 GN 1/1x65	1.210W	90°C	SI





HIGH POWER LEDS  
CRISTAL TEMPLADO  
TEMPERED GLASS  
VITRE EN VERRE TREMPÉ

CRISTAL ABATIBLE  
FOLDING GLASS  
VITRE ABATTABLE

ACCESORIO  
ACCESSORY  
ACCESSOIRE  
PGS. 185

CAPACIDAD PARA 8 BANDEJAS GN1/6 X 65  
CAPACITY FOR 8 GN 1/6X65 TRAYS  
CAPACITÉ POUR 8 BACS GN 1/6 X 65

BANDEJAS INCLUIDAS (PC)  
TRAYS INCLUDED (PC)  
BACS INCLUS (PC)

SISTEMA DE CIERRE EN ACERO PARA MANTENER RESGUARDADO EL PRODUCTO EN LOS MOMENTOS DE NO USO  
STAINLESS CLOSING SYSTEM TO MAINTAIN THE PRODUCT PROTECTED AT NON-USE PERIODS  
SYSTÈME DE FERMETURE EN ACIER INOXYDABLE POUR PROTEGER LE PRODUIT EN PÉRIODE DE NON UTILISATION

ACABADO EN FORMA DE DIAMANTE PARA LA OPTIMIZACIÓN DEL ESPACIO VISUAL  
FINISHED IN DIAMOND SHAPE TO OPTIMIZE VISUAL SPACE.  
FINITION EN FORME DE DIAMANT POUR L'OPTIMISATION DE L'ESPACE VISUEL

TERMOSTATO ELECTRÓNICO REGULABLE  
ADJUSTABLE ELECTRONIC THERMOSTAT  
THERMOSTAT ELECTRONIQUE REGLABLE

Espectacular diseño de expositor refrigerado, muy versátil, para alojar los ingredientes topping (frutas, chocolates...) de yogures y helados.

Ideal para heladerías, yogurterías o buffets de desayuno, en tamaño muy reducido para adaptarse a cualquier espacio.

8 Bandejas gastronorm GN1/6 X 65mm

Construidas en acero inoxidable y cristal templado.

Sistema de iluminación de última generación HIGH POWER LEDS.

Modelos compactos de sobre mostrador, sin necesidad de instalación.

Posibilidad de personalización para grandes series.

Spectacular refrigerated display cabinet design, very versatile to accommodate the topping ingredients (fruits, chocolate) of yoghourts and ice creams.

Ideal for yoghourt and ice cream shops, breakfast buffets, in a very compact size to fit in any space size.

8 GN 1/6X65 trays included.

Manufactured in stainless steel and tempered glass.

Latest technology HIGH POWER LEDS lighting system.

Compact models for countertop use No need of installation.

Customisation possible for large orders.

Design spectaculaire d'exposition réfrigérée, très versatile, pour y loger les ingrédients topping (fruits, chocolats) yaourts

Idéale pour yaourteries ou buffets de petits déjeuners, avec un volume très réduit s'adaptant dans n'importe quel espace.

8 Bacs gastronorm GN1/6 - 65mm

Construites en acier inoxydable et vitres en verre trempé

Système d'illumination de dernière génération HIGH POWER LEDS

Modèles compacts de comptoirs sans nécessité d'installation

Possibilité de personnalisation pour grandes séries.

#### TOPPING BOX

	MEDIDAS	BANDEJA	TEMP. (FOOD ZONE)	LED
TBT	785 X 675 X 525/300	8 GN 1/6X65	+2/+6°C	SI



CAPACIDAD PARA 6 BANDEJAS GN1/6 X 65 (PC)  
CAPACITY FOR FOR 6 GN 1/6X65 TRAYS (PC)  
CAPACITÉ POUR 6 BACS GN 1/6 X 65 (PC)

SERIGRAFÍA VITRIFICADA  
VITRIFIED SCREENPRINT  
ÉCRAN VITRIFIÉ

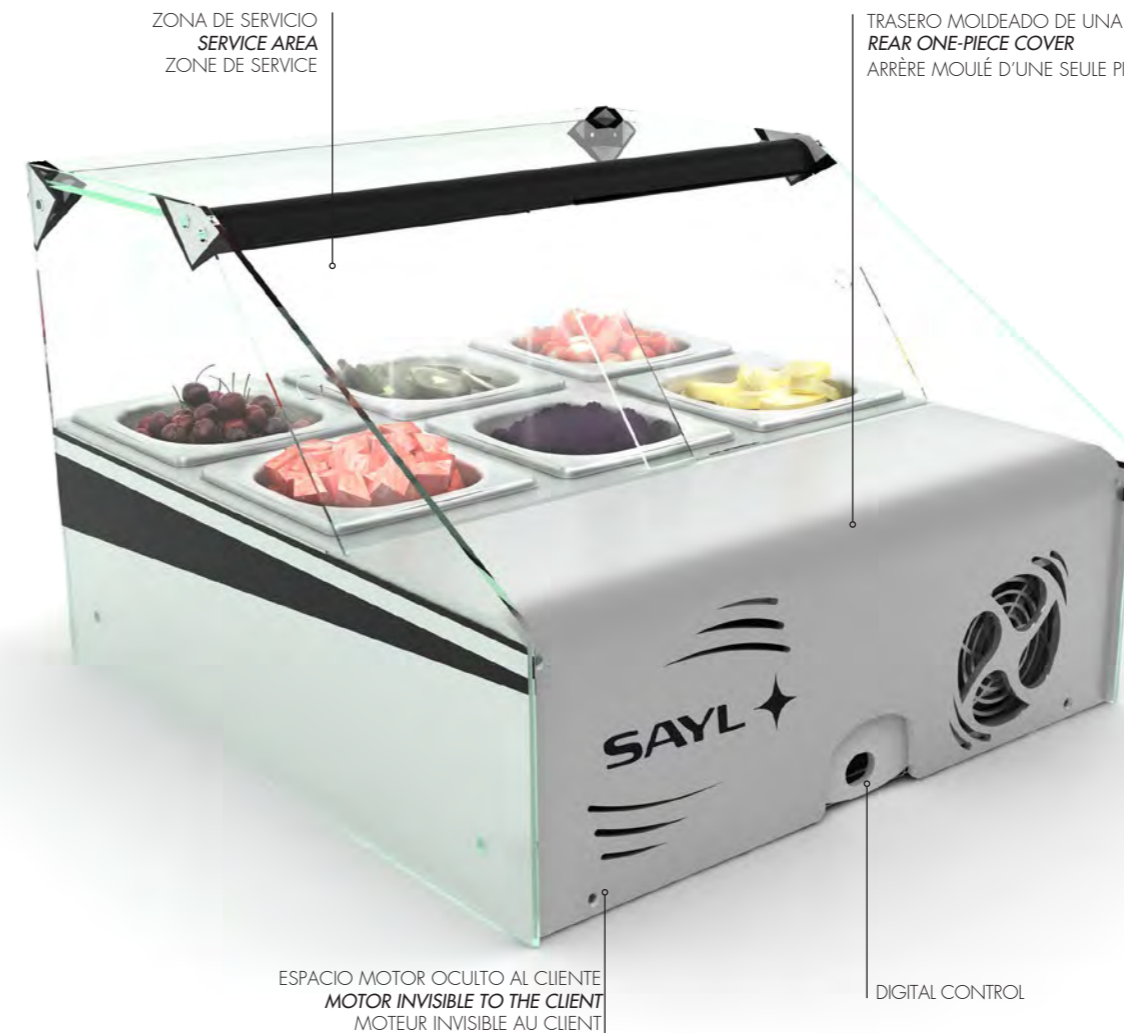

**TOPPING MINI**

	MEDIDAS	BANDEJA	TEMP. (FOOD ZONE)	LED
<b>TBM</b>	575 X 610 X 400	6 GN 1/6X65	+4/+8°C	SI

Práctico diseño de expositor refrigerado, muy versátil, para alojar los ingredientes topping (frutas, chocolates...) de yogures y helados

Ideal para heladerías, yogurterías o buffets de desayuno, en tamaño muy reducido para adaptarse a cualquier espacio.

6 Bandejas gastronorm GN1/6 X 65mm

Construidas en acero inoxidable y cristales templados.

Sistema de iluminación de última generación HIGH POWER LEDS.

Modelos compactos de sobre mostrador, sin necesidad de instalación.

Posibilidad de personalización para grandes series.

Funny refrigerated display cabinet design, very versatile to accommodate the topping ingredients (fruits, chocolate) of yoghourts and ice creams.

Ideal for yoghourt and ice cream shops, breakfast buffets, in a very compact size to fit in any space size.

8 GN 1/6X65 trays included.

Manufactured in stainless steel and tempered glass.

Last generation lighting system HIGH POWER LEDS .

Compact models for countertop use No need of installation.

Customisation possible for large orders

Design sympathique d'exposition réfrigérée, très versatile, pour y loger les ingrédients topping (fruits, chocolats) yaourts

Ideal pour yaourteries ou buffets de petits déjeuners, avec un volume très réduit s'adaptant dans n'importe quel espace.

6 Bacs gastronorme GN1/6 - 65mm

Construites en acier inoxydable et vitres en verre trempé

Système d'illumination de dernière génération HIGH POWER LEDS

Modèles compacts de comptoirs de bars sans nécessité d'installation

Possibilité de personnalisation pour grandes séries

# TAPAS



4B



6B



8B



10B



CUBA EMBUTIDA AISI304 SIN ÁNGULOS  
*AISI304 PRESSED VAT WITHOUT ANGLES*  
 CUVE MARQUETÉE AISI304 SANS ANGLE.



POSIBILIDAD DE CUBA PLANA  
*POSSIBILITY OF FLAT VAT*  
 POSSIBILITÉ DE CUVE PLANE (SANS BAC)



PIES REGULABLES  
*ADJUSTABLE LEGS*  
 PIEDS RÉGLABLES



TERMOSTATO ELECTRÓNICO REGULABLE "SAYL-BLUE"  
*"SAYL-BLUE" ADJUSTABLE ELECTRONIC THERMOSTAT*  
 THERMOSTAT ÉLECTRONIQUE RÉGLABLE "SAYL-BLUE"



ZONA MOTOR PROTEGIDA  
*MOTOR AREA PROTECTED*  
 ZONE DU MOTEUR PROTÉGÉE



SUPERFICIE SUPERIOR PLANA  
*FLAT TOP SURFACE*  
 SURFACE SUPÉRIEURE PLANE

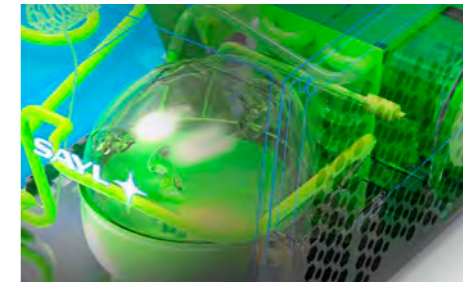

COMPONENTES DE MÁXIMA CALIDAD  
*HIGHEST QUALITY COMPONENTS*  
 LES PLUS ÉLEVÉS DES COMPOSANTS DE QUALITÉ



JUEGO DE SOPORTES VOLADIZOS COMPATIBLES  
*CANTILEVER SUPPORT SET COMPATIBLE*  
 JEU DE SUPPORTS EN SAILLIE COMPATIBLE

## LOGIC TRIPLE

## SLIM

## CUBE

## SHARK -2P

## DOS PISOS

## LOGIC SUSHI

## SHARK

## SELF-SERVICE

## STANDARD

## LOGIC

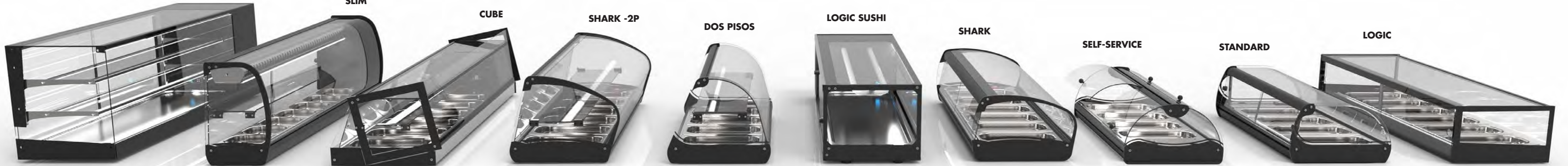



SAYL  
LOGIC LINE



MODELOS LOGIC



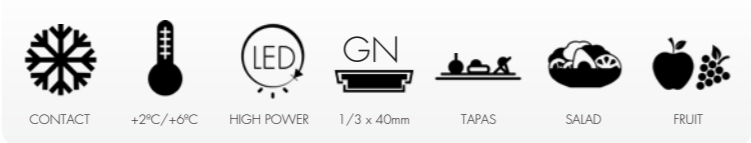

AMPLIA SUPERFICIE SUPERIOR PLANA  
FLAT TOP SURFACE  
SURFACE SUPÉRIEURE PLANE

CRISTALES TEMPLADOS  
TEMPERED GLASS  
VITRES EN VERRE TREMPÉ

CRISTAL FRONTAL COMPLETO  
COMPLETE FRONT GLASS  
VITRE FRONTALE COMPLÈTE

GRUPO MOTOR MÁS REDUCIDO DEL MERCADO  
THE MOST REDUCED ENGINE OF THE MARKET  
GROUPE MOTEUR LE PLUS RÉDUIT DU MARCHÉ

OPCIÓN MOTOR EN EL LADO CONTRARIO  
OPTIONAL SIDE OPTION  
OPTION MOTEUR A CÔTÉ OPPOSÉ



**VTLG8**

BANDEJAS INCLUIDAS GN 1/3 X 40  
GN 1/3 x 40 TRAYS INCLUDED  
BACS INCLUS GN 1/3 X 40



**VTLG8**

PIES REGULABLES  
ADJUSTABLE LEGS  
PIEDS RÉGLABLES

VITRINA CON MÁXIMA VISIBILIDAD  
MAXIMUM VISIBILITY DISPLAY CABINET  
VITRINE AVEC UN MAXIMUM DE VISIBILITÉ



**VTLG6**

DESAGÜE INCORPORADO  
BUILT-IN DRAINAGE  
VIDANGE INCORPORÉ

CUBA EMBUTIDA AISI304 SIN ÁNGULOS  
AISI304 PRESSED VAT WITHOUT ANGLES  
CUVE MARQUETÉE AISI304 SANS ANGLE

SISTEMA "LIMPIEZA FÁCIL"  
SIN ÁNGULOS EN LA CUBA  
"EASY TO CLEAN" SYSTEM  
VAT WITHOUT ANGLES  
SYSTÈME "NETTOYAGE FACILE"  
SANS ANGLE DANS LA CUVE

VITRINA INTEGRABLE EN BARRA  
CAN BE INTEGRATED INTO THE COUNTERTOP  
VITRINE INTÉGRABLE SUR COMPTOIR DE BAR



**VTLG8P**

PERFIL PROTECTOR DE CRISTAL  
GLASS PROTECTIVE PROFILE  
PROFILÉ PROTECTEUR DES VITRES



DISPONIBLE EN GRUPO REMOTO  
AVAILABLE IN REMOTE GROUP  
DISPONIBLE AU GROUPE À DISTANCE



TERMOSTATO ELECTRÓNICO REGULABLE "SAYL-BLUE"  
"SAYL-BLUE" ADJUSTABLE ELECTRONIC THERMOSTAT  
THERMOSTAT ÉLECTRONIQUE RÉGLABLE "SAYL-BLUE"



**VTLG6**



**VTLG6-I**



SUPERFICIE SUPERIOR PLANA  
TOP FLAT  
SURFACE SUPÉRIEURE PLANE

**LOGIC TAPAS**

	MEDIDAS	CRISTAL TEMPLADO	BANDEJA	TEMP. (FOOD ZONE)	LED
<b>VTLG4</b>	970x380x225	SI	4 GN 1/3x40	+2/+6°C	SI
<b>VTLG6</b>	1320x380x225	SI	6 GN 1/3x40	+2/+6°C	SI
<b>VTLG8</b>	1680x380x225	SI	8GN 1/3x40	+2/+6°C	SI
<b>VTLG4P</b>	970x380x225	SI	CUBA PLANA	+2/+6°C	SI
<b>VTLG6P</b>	1320x380x225	SI	CUBA PLANA	+2/+6°C	SI
<b>VTLG8P</b>	1680x380x225	SI	CUBA PLANA	+2/+6°C	SI



NEW



CALENTADOR LOGIC 1P SAHARA

	MEDIDAS	TIPO DE CALOR	BANDEJAS	POTENCIA	TEMP.(MAX)	LED
<b>CLO4S</b>	840x395x225	SECO	SIN BANDEJAS	800W	90°C	NO
<b>CLO6S</b>	1190x395x225	SECO	SIN BANDEJAS	1.000W	90°C	NO
<b>CLO4SL</b>	840x395x225	SECO	SIN BANDEJAS	800W	90°C	SI
<b>CLO6SL</b>	1190x395x225	SECO	SIN BANDEJAS	1.000W	90°C	SI



CALENTADOR LOGIC 1P BAÑO MARIA

	MEDIDAS	TIPO DE CALOR	BANDEJAS	POTENCIA	TEMP. (MAX)	LED
<b>CLO4B</b>	840x395x225	BAÑO MARIA	4 GN 1/3x40	800W	90°C	NO
<b>CLO6B</b>	1190x395x225	BAÑO MARIA	6 GN 1/3x40	1.000W	90°C	NO
<b>CLO4BL</b>	840x395x225	BAÑO MARIA	4 GN 1/3x40	800W	90°C	SI
<b>CLO6BL</b>	1190x395x225	BAÑO MARIA	6 GN 1/3x40	1.000W	90°C	SI



La única vitrina sushi del mercado construida en cristales dobles.

Porque siempre mantengo una perfecta visibilidad del producto sin producir condensación en los cristales, tengo una mejor estabilidad de temperatura interior y consumo mucha menos energía!

*The only sushi display case of the market built with double glazed glass.*

Perfect visibility in unfavorable humidity conditions, greater temperature stability and reduced energy consumption.

L'unique vitrine à Sushi sur le marché fabriquée en double vitrage.

Parce que je maintiens toujours une parfaite visibilité des aliments présentés sans produire de condensation sur les vitres, j'ai une meilleure stabilité de température intérieure et je consomme beaucoup moins d'énergie !



LOGIC LINE

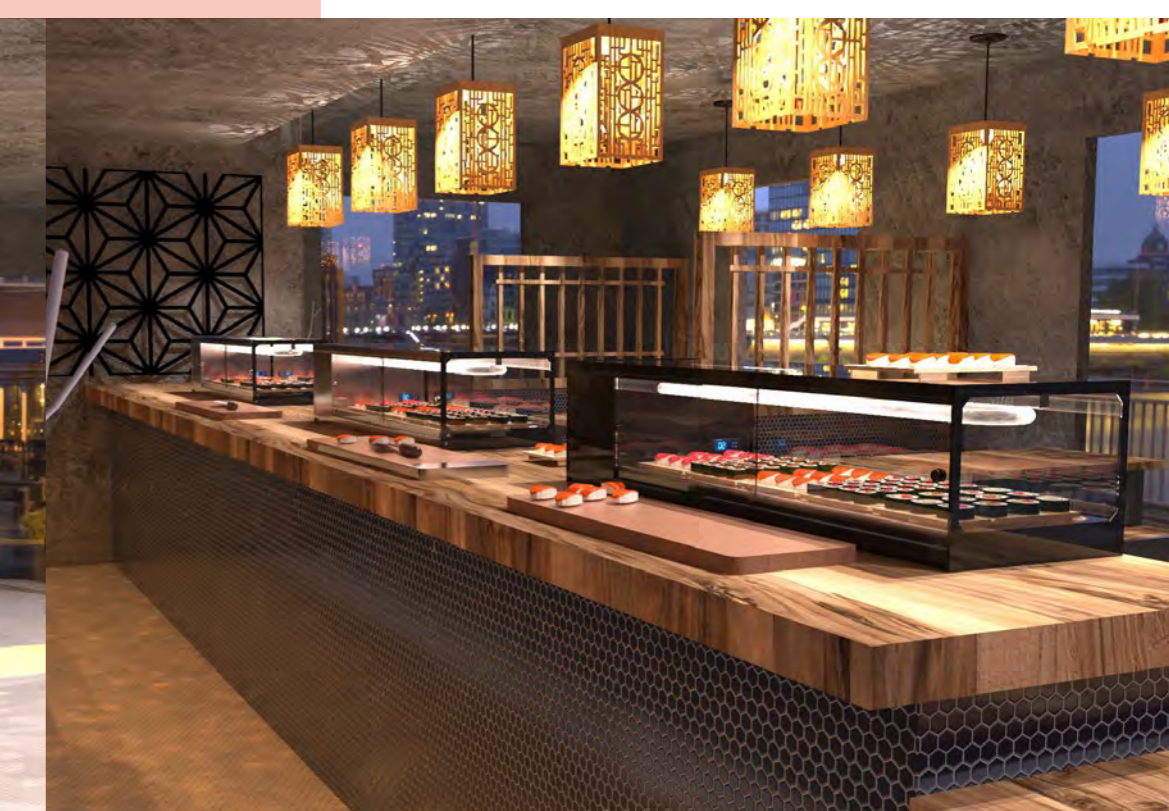
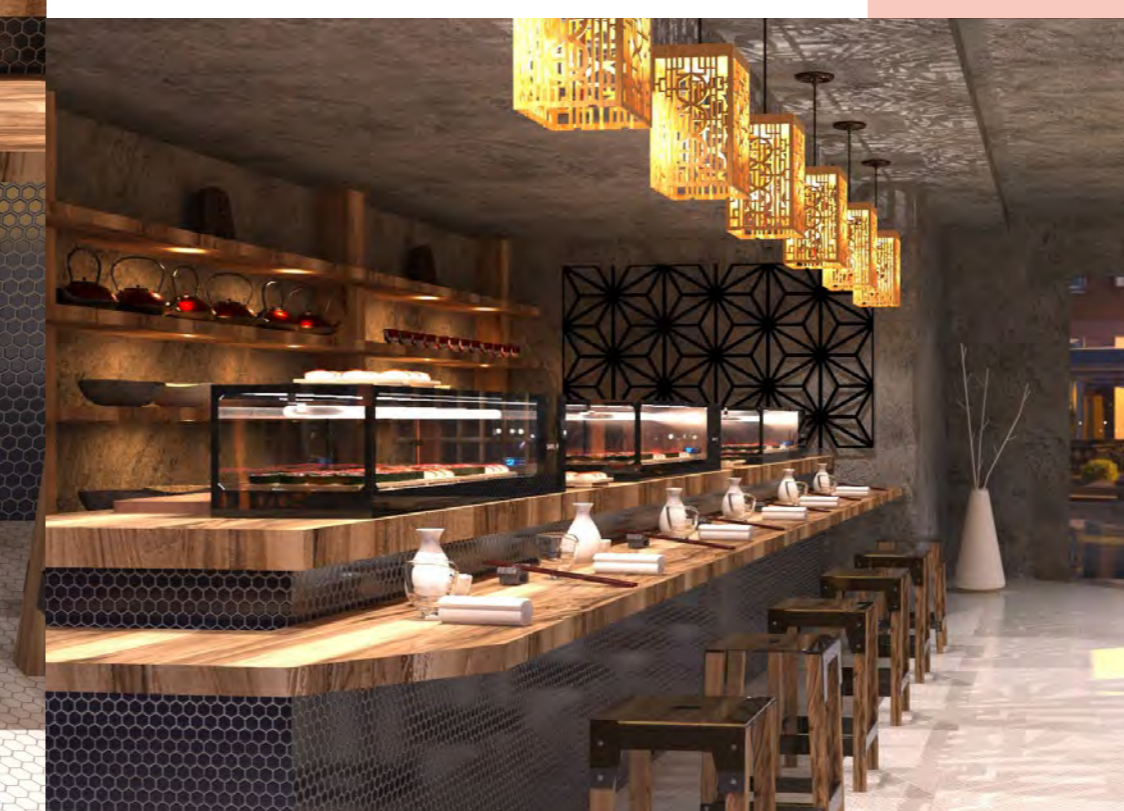



UNICA VITRINA SUSHI CONSTRUIDA CON CRISTAL CÁMARA  
**THE ONLY SUSHI DISPLAY CASE OF THE MARKET BUILT WITH DOUBLE GLAZED GLASS**  
 UNIQUE VITRINE SUSHI CONSTRUITE EN VERRE DOUBLE VITRAGE



CRISTAL FRONTAL COMPLETO  
**COMPLETE FRONT GLASS**  
 VITRE FRONTALE COMPLÈTE

+0°/+4°C

GRUPO MOTOR MÁS REDUCIDO DEL MERCADO  
**THE MOST REDUCED ENGINE OF THE MARKET**  
 GROUPE MOTEUR LE PLUS RÉDUIT DU MARCHÉ

SUPERIOR CRISTAL CÁMARA  
**TOP DOUBLE GLAZED GLASS**  
 VITRE SUPÉRIEURE EN VERRE DOUBLE VITRAGE



MÁXIMA VISIBILIDAD INCLUSO EN CONDICIONES DE HUMEDAD DESFAVORABLES  
**MAXIMUM VISIBILITY EVEN UNDER HUMIDITY UNFAVOURABLE CONDITIONS**  
 VISIBILITÉ MAXIMALE AVEC DES CONDITIONS DÉFAVORISANT L' HUMIDITÉ

LATERAL EN CRISTAL CÁMARA  
**LATERAL DOUBLE GLAZED GLASS**  
 LATÉRAL EN VERRE DOUBLE VITRAGE



SAYL

LOGIC LINE



**ZONA SUPERIOR PLANA**  
**FLAT TOP SURFACE**  
**ZONE SUPERIEURE PLANE**

VIDRIO TEMPLADO PARA GANAR MÁS ESPACIO DE TRABAJO  
**TEMPERED CRYSTALS TO GAIN MORE WORKSPACE ON TOP**  
 VERRE TREMPÉ POUR GAGNER PLUS D'ESPACE DE TRAVAIL



**DOBLE ILUMINACIÓN**  
**DOUBLE LIGHTING**  
**DOUBLE ECLAIRAGE**

SIN SOMBRAS INDESEADAS EN TU PRODUCTO  
**ALWAYS WITHOUT UNDESIRABLE SHADOWS ON THE PRODUCT**  
 POUR NE PAS CRÉER DE ZONES D'OMBRES SUR LES PRODUITS.



**GRAN ALTURA DE ACCESO**  
**ACCESS HEIGHT**  
**GRANDE HAUTEUR D'ACCES**

PARA PODER TRABAJAR EN SU INTERIOR CÓMODAMENTE  
**TO WORK COMFORTABLY INSIDE.**  
 POUR TRAVAILLER FACILEMENT À L'INTÉRIEUR DE LA VITRINE.



**FÁCIL DE LIMPIAR**  
**EASY TO CLEAN**  
**NETTOYAGE FACILE**

CUBA INTERIOR EMBUTIDA SIN ÁNGULOS Y CON DESAGÜE  
**PRESSED VAT PROVIDED WITH DRAINAGE, WITHOUT ANGLES**  
 CUVE INTÉRIÈRE MARQUETÉE SANS ANGLE ET AVEC ÉVACUATION



AMPLIA SUPERFICIE SUPERIOR PLANA  
**FLAT TOP SURFACE**  
 SURFACE SUPÉRIEURE PLANE

POTENTE EVAPORADOR DE FÁCIL LIMPIEZA  
**EASY-CLEANING POWERFUL EVAPORATOR**  
 PUISSANT ÉVAPORATEUR FACILITANT LE NETTOYAGE

**LOGIC SUSHI**

	MEDIDAS	CRISTAL TEMPLADO	BANDEJA	TEMP. (FOOD ZONE)	LED
<b>VTLG6S</b>	1320x380x300	SI	6 GN 1/3x40	+0/+4°C	SI
<b>VTLG6SP</b>	1320x380x300	SI	CUBA PLANA	+0/+4°C	SI





LOGIC TRIPLE  
SAHARA  
70°C



LOGIC TRIPLE  
BAÑO MARÍA  
80°C



LOGIC TRIPLE  
TAPAS  
+2°C / +6°C



ES

Termostato electrónico ajustable con lectura digital constante.  
Sensores electrónicos ocultos fuera de posibles manipulaciones.  
Cuba embutida provistas de desagüe y sin ángulos que facilitan la limpieza.  
Puertas correderas de fácil extracción y limpieza.  
Cubierta de cristal vitrificado resistente a golpes, roces, ácidos y detergentes habituales.  
Conserva los alimentos entre 2°C y 6°C en la "food zone".  
Compresor hermético silencioso con doble condensador turbo ventilado de alta calidad Danfoss.  
Cuba con capacidad para 4,6 y 8 bandejas gastronorm 1/3 - 40 AISI INOX incluidas.  
Todos los modelos disponibles con cuba plana.  
Construidas en acero inoxidable y cristales templados.  
Modelos compactos de sobremostrador, sin necesidad de instalación con patas regulables.

EN

Adjustable electronic thermostat with constant digital reading.  
Hidden electronic sensors without possibility of handling.  
Pressed vat provided with drainage, without angles for easy cleaning.  
Sliding doors easy to extract and clean.  
Vitrified glass cover resistant to shock, friction, acids and detergents  
Food preservation from 2°C to 6°C at the "food zone".  
High-quality watertight silent compressor Danfoss with a ventilated dual turbo condenser.  
Vat capacity for 4, 6,8 trays included (gastronorm 1/3-40 inox aisi)  
All models are available on flat vat .  
Manufactured in stainless steel and tempered glass.  
Compact models designed for countertop use no need of installation, adjustable legs.

FR

Thermostat électronique réglable avec lecture digitale constante.  
Capteurs électroniques invisibles hors de possibles manipulations.  
Cuve marquetée, équipée pour la vidange de l'eau et sans angle, facilitant le nettoyage.  
Portes coulissantes avec extraction et nettoyage faciles.  
Verre vitrifié résistant aux coups, aux frottements, aux acides et détergents habituels.  
Conservation des aliments entre 2°C et 6°C dans la zone des bacs.  
Compresseur hermétique silencieux avec double condensateur ventilé de haute qualité Danfoss.  
Cuve avec une capacité de 4,6,8 bacs gastronorme 1/3 - 40 AISI INOX inclus.  
Tous les modèles disponibles avec cuve plane (sans bac).  
Construites en acier inoxydable et vitres en verre trempé.  
Modèles compacts de comptoirs, sans nécessité d'installation avec pieds réglables.



LED SUPERIOR  
SUPERIOR LED  
SUPERIEURELED

SUPERFICIE SUPERIOR PLANA  
TOP FLAT  
SURFACE SUPERIEURE PLANE

GRUPO MOTOR MÁS REDUCIDO DEL MERCADO  
THE MOST REDUCED ENGINE OF THE MARKET  
GROUPE MOTEUR LE PLUS RÉDUIT DU MARCHÉ

DOBLE LED EN CADA ALTURA  
DOUBLE LED IN EVERY SHELF  
DOUBLE LEDS A CHAQUE ÉTAGE

ESTANTES REGULABLES  
REGULABLE SHELVES  
ÉTAGÈRES RÉGULABLES



CRISTAL FRONTAL COMPLETO  
COMPLETE FRONT GLASS  
VITRE FRONTALE COMPLÈTE

+4°C/+8°C

PERFIL PROTECTOR DE CRISTAL  
GLASS PROTECTIVE PROFILE  
PROFILÉ PROTECTEUR DES VITRES

VITRINA CON MÁXIMA VISIBILIDAD  
MAXIMUM VISIBILITY DISPLAY CABINET  
VITRINE AVEC UN MAXIMUM DE VISIBILITÉ

MAXIMA VISIBILIDAD E ILUMINACIÓN I



ESCOGE UNO O DOS ESTANTES :



VERSIONES BANDEJAS GN



BANDEJAS INCLUIDAS GN 1/3 X 40  
GN 1/3 x 40 TRAYS INCLUDED  
BACS INCLUS GN 1/3 X 40

VERSIONES CUBA PLANA



CUBA EMBUTIDA AISI304 SIN ÁNGULOS  
AISI304 PRESSED VAT WITHOUT ANGLES  
CUVE MARQUETÉE AISI304 SANS ANGLE



VTLG24



VTLG26



VTLG28

PIES REGULABLES  
ADJUSTABLE LEGS  
PIEDS RÉGLABLES

VITRINAS LOGIC 2P - COMPACTAS - REGULABLES.

	MEDIDAS	CRISTAL TEMPLADO	BANDEJA	TEMP. (FOOD ZONE)	LED
<b>VTLG24</b>	970x380x460	SI	4 GN 1/3x40	+2/+6°C	SI
<b>VTLG26</b>	1320x380x460	SI	6 GN 1/3x40	+2/+6°C	SI
<b>VTLG28</b>	1680x380x460	SI	8GN 1/3x40	+2/+6°C	SI
<b>VTLG24P</b>	970x380x460	SI	CUBA PLANA	+2/+6°C	SI
<b>VTLG26P</b>	1320x380x460	SI	CUBA PLANA	+2/+6°C	SI
<b>VTLG28P</b>	1680x380x460	SI	CUBA PLANA	+2/+6°C	SI



DISPONIBLE EN GRUPO REMOTO  
EN VISIONES CALENTADOR Y NEUTRO .

LOGIC TRIPLE

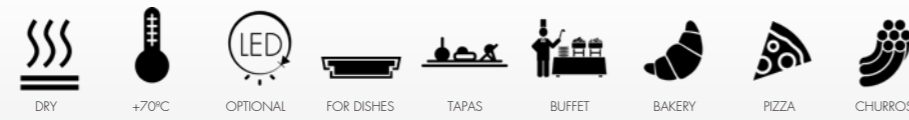

NEW

DOBLE LED EN CADA ALTURA  
DOUBLE LED IN EVERY SHELF  
DOUBLE LEDS A CHAQUE ÉTAGE



TEMPERATURA REGULABLE  
TEMPERATURE-CONTROLLED  
TEMPÉRATURE RÉGLABLE

FABRICADAS EN ACERO AISI 304  
MANUFACTURED IN AISI 304 STAINLESS STEEL  
FABRIQUÉES EN ACIER INOXYDABLE AISI 304

INTERIOR DESMONTABLE PARA LIMPIEZA  
REMOVABLE INTERIOR FOR EASY CLEANING  
INTÉRIEUR DÉMONTABLE POUR LE NETTOYAGE

+++  
+70°C

CLO26S

ESTANTES REGULABLES  
REGULABLE SHELVES  
ÉTAGÈRES RÉGLABLES



CRISTALES TEMPLADOS  
TEMPERED GLASS  
TEMPÉRÉE VERRE

DOBLE LED EN CADA ALTURA  
DOUBLE LED IN EVERY SHELF  
DOUBLE LEDS A CHAQUE ÉTAGE

DESAGÜE PARA FACILITAR LA LIMPIEZA  
EASY CLEANING DRAINAGE  
ÉGOUTTER POUR UN NETTOYAGE FACILE

+++  
+80°C

CLO26B

ESTANTES REGULABLES  
REGULABLE SHELVES  
ÉTAGÈRES RÉGLABLES



HIGH POWER LEDS



BANDEJAS INCLUIDAS GN 1/3 X 40  
GN 1/3 X 40 TRAYS INCLUDED  
PLATEAU INCLUS GN 1/3 X 40



TEMPERATURA REGULABLE  
TEMPERATURE-CONTROLLED  
TEMPÉRATURE RÉGLABLE



CALENTADOR LOGIC 2P - SAHARA

	MEDIDAS	TIPO DE CALOR	BANDEJAS	POTENCIA	TEMP.(MAX)	LED
<b>CLO24S</b>	840x395x460	SECO	SIN BANDEJAS	800W	70°C	SI
<b>CLO26S</b>	1190x395x460	SECO	SIN BANDEJAS	1.000W	70°C	SI

CALENTADOR LOGIC 2P - BAÑO MARIA

	MEDIDAS	TIPO DE CALOR	BANDEJAS	POTENCIA	TEMP.(MAX)	LED
<b>CLO24B</b>	840x395x460	BAÑO MARIA	4 GN 1/3x40	800W	80°C	SI
<b>CLO26B</b>	1190x395x460	BAÑO MARIA	6 GN 1/3x40	1.000W	80°C	SI

SAYL  
LOGIC TRIPLE



TRIPLE EXPOSICIÓN EN EL MISMO ESPACIO  
TRIPLE EXHIBITION ON THE SAME SPACE  
TRIPLE EXPOSITION LE MÊME ESPACE

PLANO SUPERIOR  
FLAT TOP  
PLAN SUPÉRIEUR

ESTANTE INTERMEDIO DE CRISTAL  
MIDDLE GLASS SHELF  
ÉTAGÈRE EN VERRE INTERMÉDIAIRE

HIGH POWER LEDS

"SAYL BLUE" DIGITAL CONTROL



+2°C/+6°C



ESPECTACULAR DISEÑO CUBE  
SPECTACULAR CUBE DESIGN  
SPECTACULAIRE DESIGN DE LA VITRINE CUBE

FABRICADAS EN ACERO INOX  
MANUFACTURED IN STAINLESS STEEL  
FABRIQUÉES EN ACIER INOXYDABLE

BANDEJAS INCLUIDAS GN 1/3 X 40  
GN 1/3 x 40 TRAYS INCLUDED  
BACS INCLUS GN 1/3 X 40



VCB4



VCB6



VCB8

DOBLE ESTANTE DE CRISTAL TEMPLADO  
DOUBLE TEMPERED GLASS SHELF  
DOUBLE EN VERRE TREMPÉ



CUBE	MEDIDAS	ESTANTE NEUTRO	BANDEJA	TEMP. (FOOD ZONE)	LED
VCB4	1085x395x350	720x195	4 GN 1/3x40	+2/+6°C	SI
VCB6	1438x395x350	1075x195	6 GN 1/3x40	+2/+6°C	SI
VCB8	1788x395x350	1425x195	8 GN 1/3x40	+2/6°C	SI
VCB4P	1085x395x350	720x195	CUBA PLANA	+2/+6°C	SI
VCB6P	1438x395x350	1075x195	CUBA PLANA	+2/+6°C	SI
VCB8P	1788x395x350	1425x195	CUBA PLANA	+2/6°C	SI

POSIBILIDAD DE ILUMINACIÓN EN EL ESTANTE (DOBLE ILUMINACIÓN) OPCIONAL - OPTIONAL DOUBLE LIGHTING ON THE SHELF - EN OPTION : POSSIBILITÉ DE DOUBLE ILLUMINATION SUR L'ÉTAGÈRE

SAYL  
LINE  
CUBE

CUBE  
135



SAYL ✦  
LINE  
**SHARK**

SHARK TAPAS 1P  
+2°C / +6°C



SHARK SUSHI 1P  
+2°C / +6°C



SHARK TAPAS 2P  
+2°C / +6°C



SHARK SUSHI 2P  
+2°C / +6°C

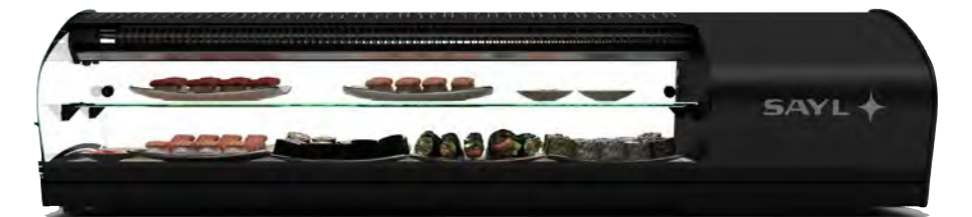

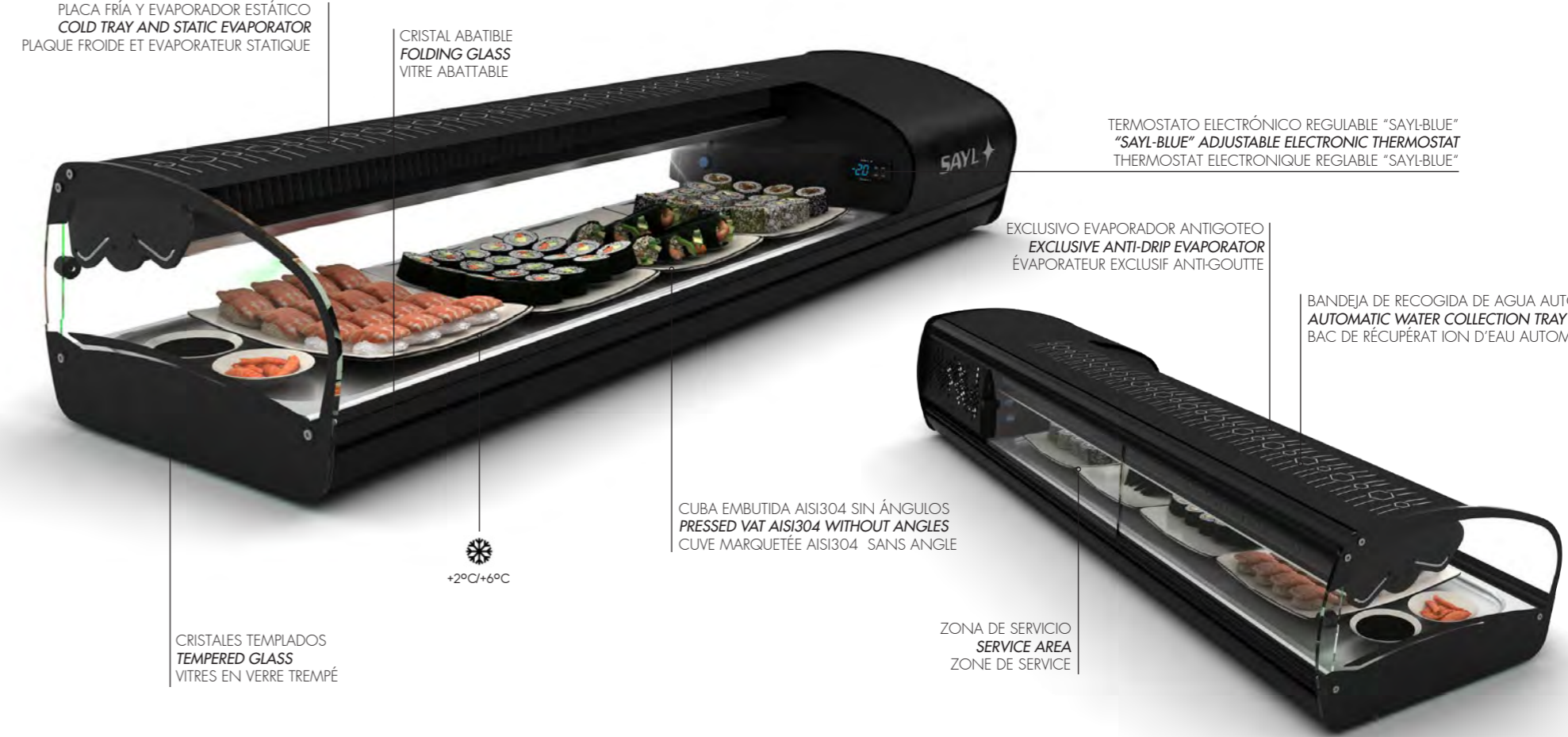
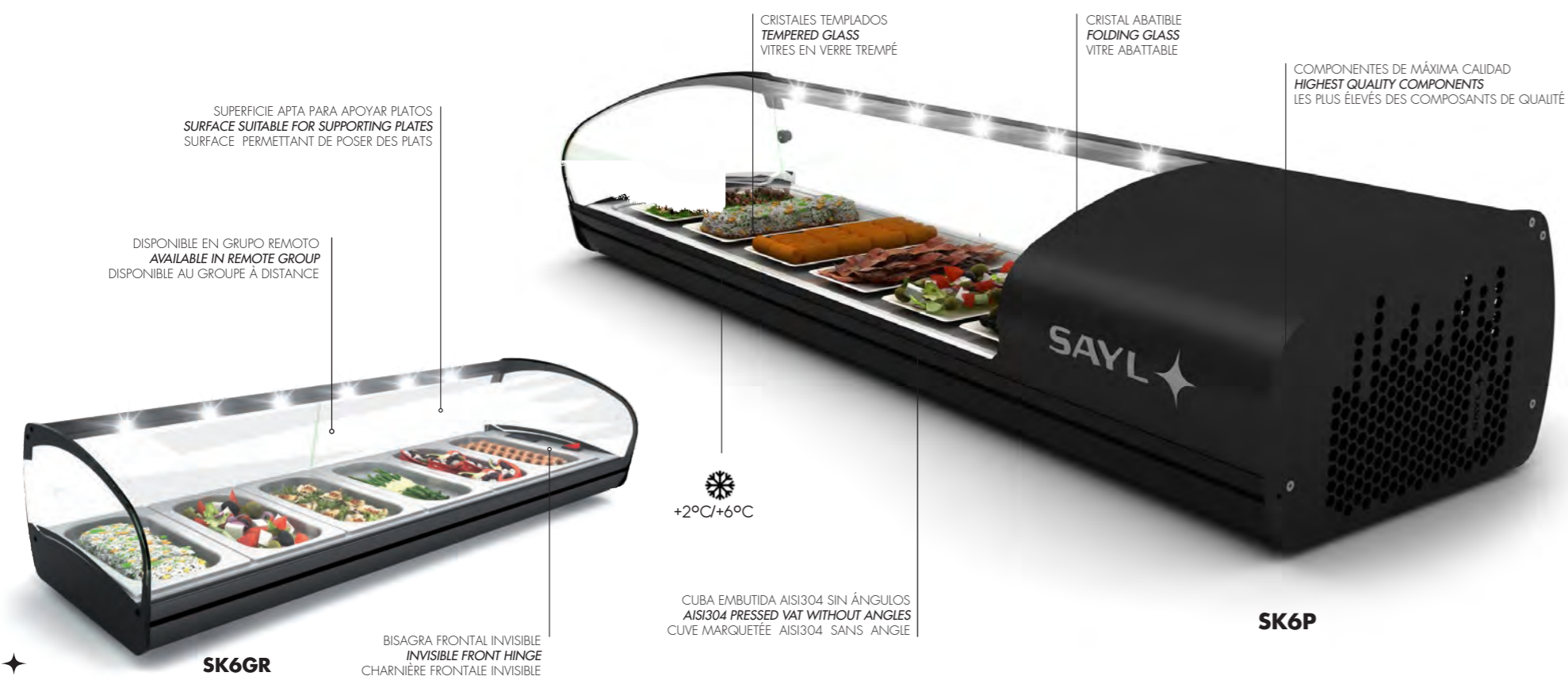

SUPERFICIE APTA PARA APOYAR PLATOS  
SURFACE SUITABLE FOR SUPPORTING PLATES  
SURFACE PERMETTANT DE POSER DES PLATS

DISPONIBLE EN GRUPO REMOTO  
AVAILABLE IN REMOTE GROUP  
DISPONIBLE AU GROUPE À DISTANCE

CRISTALES TEMPLADOS  
TEMPERED GLASS  
VITRES EN VERRE TREMPÉ

CRISTAL ABATIBLE  
FOLDING GLASS  
VITRE ABATTABLE

COMPONENTES DE MÁXIMA CALIDAD  
HIGHEST QUALITY COMPONENTS  
LES PLUS ÉLEVÉS DES COMPOSANTS DE QUALITÉ

PLACA FRÍA Y EVAPORADOR ESTÁTICO  
COLD TRAY AND STATIC EVAPORATOR  
PLAQUE FROIDE ET EVAPORATEUR STATIQUE

CRISTAL ABATIBLE  
FOLDING GLASS  
VITRE ABATTABLE

TERMOSTATO ELECTRÓNICO REGULABLE "SAYL-BLUE"  
"SAYL-BLUE" ADJUSTABLE ELECTRONIC THERMOSTAT  
THERMOSTAT ELECTRONIQUE REGLABLE "SAYL-BLUE"

+2°C/+6°C

CUBA EMBUTIDA AISI304 SIN ÁNGULOS  
AISI304 PRESSED VAT WITHOUT ANGLES  
CUVE MARQUETÉE AISI304 SANS ANGLE

SK6P

CRISTALES TEMPLADOS  
TEMPERED GLASS  
VITRES EN VERRE TREMPÉ

+2°C/+6°C

CUBA EMBUTIDA AISI304 SIN ÁNGULOS  
PRESSED VAT AISI304 WITHOUT ANGLES  
CUVE MARQUETÉE AISI304 SANS ANGLE

EXCLUSIVO EVAPORADOR ANTIGOTEÓ  
EXCLUSIVE ANTI-DRIP EVAPORATOR  
ÉVAPORATEUR EXCLUSIF ANTI-GOUTTE

BANDEJA DE RECOGIDA DE AGUA AUTOMÁTICA  
AUTOMATIC WATER COLLECTION TRAY  
BAC DE RÉCUPÉRAT ION D'EAU AUTOMATIQUE

ZONA DE SERVICIO  
SERVICE AREA  
ZONE DE SERVICE

SHARK 1P TAPAS

	MEDIDAS	PROFUNDIDAD CUBA	BANDEJA	TEMP. (FOOD ZONE)	LED
SK6	1438x395x270	40mm	6 GN 1/3x40	+2/+6°C	SI
SK8	1788x395x270	40mm	8 GN 1/3x40	+2/+6°C	SI
SK6P	1438x395x270	15mm	SIN BANDEJAS	+2/+6°C	SI
SK8P	1788x395x270	15mm	SIN BANDEJAS	+2/+6°C	SI

SHARK 1P DOBLE FRIO

	MEDIDAS	PROFUNDIDAD CUBA	BANDEJA	TEMP. (FOOD ZONE)	LED
SK6S	1438x395x270	40mm	6 GN 1/3x40	+2/+6°C	SI
SK8S	1788x395x270	40mm	8 GN 1/3x40	+2/+6°C	SI
SK6SP	1438x395x270	15mm	SIN BANDEJAS	+2/+6°C	SI
SK8SP	1788x395x270	15mm	SIN BANDEJAS	+2/+6°C	SI

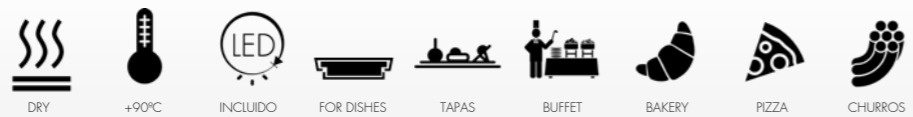

INTERIOR DESMONTABLE PARA LIMPIEZA  
REMOVABLE INTERIOR FOR EASY CLEANING  
INTÉRIEUR DÉMONTABLE POUR LE NETTOYAGE

SUPERFICIE APTA PARA APOYAR PLATOS  
SURFACE SUITABLE FOR SUPPORTING PLATES  
SURFACE PERMETTANT DE POSER DES PLATS

CRISTAL ABATIBLE  
FOLDING GLASS  
PLANTE VERRE

HIGH POWER LEDS



+++  
+90°C

CONTROL DIGITAL  
TEMPERATURA REGULABLE  
TEMPERATURE-CONTROLLED  
TEMPÉRATURE RÉGLABLE

FABRICADAS EN ACERO AISI 304  
MANUFACTURED IN AISI 304 STAINLESS STEEL  
FABRIQUÉ EN ACIER INOX 304

BANDEJA RECOGEMIGAS  
REMOVABLE CRUMB TRAY  
BAC RAMASSE MIETTES

#### SHARK 1P SAHARA

	MEDIDAS	TIPO DE CALOR	BANDEJAS	POTENCIA	TEMP. (MAX.)	LED
<b>SHK4</b>	840x395x270	SECO	SIN BANDEJAS	800W	90°C	NO
<b>SHK6</b>	1190x395x270	SECO	SIN BANDEJAS	1.000W	90°C	NO
<b>SHK4L</b>	840x395x270	SECO	SIN BANDEJAS	800W	90°C	SI
<b>SHK6L</b>	1190x395x270	SECO	SIN BANDEJAS	1.000W	90°C	SI



CRISTALES TEMPLADOS  
TEMPERED GLASS  
VITRES EN VERRE TREMPÉ

HIGH POWER LEDS

FABRICADAS EN ACERO AISI 304  
MANUFACTURED IN AISI 304  
STAINLESS STEEL  
FABRIQUÉ EN ACIER INOX 304

CRISTAL ABATIBLE  
FOLDING GLASS  
VITRE ABATTABLE

TEMPERATURA REGULABLE  
TEMPERATURE-CONTROLLED  
TEMPÉRATURE RÉGLABLE



+++  
+90°C

DESAGÜE PARA FACILITAR SU LIMPIEZA  
EASY CLEANING DRAINAGE  
VIDANGE POUR UN NETTOYAGE FACILE

INTERIOR DESMONTABLE PARA SU LIMPIEZA  
REMOVABLE INTERIOR FOR EASY CLEANING  
NETTOYAGE INTÉRIEUR DÉMONTABLE

BANDEJAS INCLUIDAS GN 1/3 X 40  
GN 1/3 X 40 TRAYS INCLUDED  
PLATEAU INCLUS GN 1/3 X 40

#### SHARK 1P BAÑO MARIA

	MEDIDAS	TIPO DE CALOR	BANDEJAS	POTENCIA	TEMP. (MAX)	LED
<b>CK4</b>	840x395x270	BAÑO MARIA	4 GN 1/3x40	800W	90°C	NO
<b>CK6</b>	1190x395x270	BAÑO MARIA	6 GN 1/3x40	1.000W	90°C	NO
<b>CK4L</b>	840x395x270	BAÑO MARIA	4 GN 1/3x40	800W	90°C	SI
<b>CK6L</b>	1190x395x270	BAÑO MARIA	6 GN 1/3x40	1.000W	90°C	SI



VITRINA CON MÁXIMA VISIBILIDAD  
MAXIMUM VISIBILITY DISPLAY CABINET  
VITRINE MAXIMUM DE VISIBILITÉ

ESTANTE INTERMEDIO DE CRISTAL  
MIDDLE GLASS SHELF  
ÉTAGÈRE INTERMÉDIAIRE EN VERRE

CRISTAL ABATIBLE  
FOLDING GLASS  
VITRE ABATTABLE



SK26P

CUBA EMBUTIDA AISI304 SIN ÁNGULOS  
AISI304 PRESSED VAT WITHOUT ANGLES  
CUVE MARQUETÉE AISI304 SANS ANGLE

DISPONIBLE EN GRUPO REMOTO  
AVAILABLE IN REMOTE GROUP  
DISPONIBLE AU GROUPE À DISTANCE



SK26GR

BANDEJAS INCLUIDAS GN 1/3 X 40  
GN 1/3 X 40 TRAYS INCLUDED  
BACS INCLUS GN 1/3 X 40

SHARK 2P TAPAS

	MEDIDAS	PROFUNDIDAD CUBA	BANDEJA	TEMP. (FOOD ZONE)	TEMP. (ESTANTE)	LED
SK26	1438x395x340	40mm	6 GN 1/3x40	+2/+6°C	NEUTRA	SI
SK28	1788x395x340	40mm	8 GN 1/3x40	+2/+6°C	NEUTRA	SI
SK26P	1438x395x340	15mm	SIN BANDEJAS	+2/+6°C	NEUTRA	SI
SK28P	1788x395x340	15mm	SIN BANDEJAS	+2/+6°C	NEUTRA	SI

POSIBILIDAD DE ILUMINACIÓN EN EL ESTANTE (DOBLE ILUMINACIÓN) OPCIONAL - OPTIONAL DOUBLE LIGHTING ON THE SHELF - EN OPTION : POSSIBILITÉ DE DOUBLE ILLUMINATION SUR L'ÉTAGÈRE



EXCLUSIVO EVAPORADOR ANTIGOTEÓ  
EXCLUSIVE ANTI-DRIP EVAPORATOR  
ÉVAPORATEUR EXCLUSIF ANTI-GOUTTE

LA ÚNICA VITRINA SUSHI 2 PISOS  
THE ONLY 2 FLOOR SUSHI DISPLAY  
L'UNIQUE VITRINE SUSHI 2 ÉTAGES

ESTANTE INTERMEDIO DE CRISTAL  
MIDDLE GLASS SHELF  
ÉTAGÈRE INTERMÉDIAIRE EN VERRE

PLACA FRÍA Y EVAPORADOR ESTÁTICO  
COLD TRAY AND STATIC EVAPORATOR  
PLAQUE FROIDE ÉVAPORATEUR STATIQUE

COMPONENTES DE MÁXIMA CALIDAD  
HIGHEST QUALITY COMPONENTS  
COMPOSANTS DE QUALITÉ MAXIMALE



SK26SP

BANDEJA DE RECOGIDA DE AGUA AUTOMÁTICA  
AUTOMATIC WATER COLLECTION TRAY  
BAC DE RÉCUPÉRATION D'EAU AUTOMATIQUE

+2°C /+6°C  
+8°C /+12°C

CRISTAL ABATIBLE  
FOLDING GLASS  
VITRE ABATTABLE

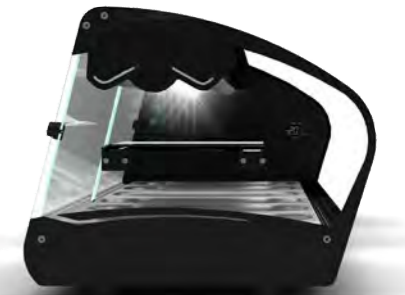

SK26S

SHARK 2P DOBLE FRIO

	MEDIDAS	PROFUNDIDAD CUBA	BANDEJA	TEMP. (FOOD ZONE)	TEMP. (ESTANTE)	LED
SK26S	1438x395x340	40mm	6 GN 1/3x40	+2/+6°C	+8/+12°C	SI
SK28S	1788x395x340	40mm	8 GN 1/3x40	+2/+6°C	+8/+12°C	SI
SK26SP	1438x395x340	15mm	SIN BANDEJAS	+2/+6°C	+8/+12°C	SI
SK28SP	1788x395x340	15mm	SIN BANDEJAS	+2/+6°C	+8/+12°C	SI

POSIBILIDAD DE ILUMINACIÓN EN EL ESTANTE (DOBLE ILUMINACIÓN) OPCIONAL-POSSIBILITY OF LIGHTING ON THE SHELF (DOUBLE ILLUMINATION) OPTIONAL - EN OPTION : POSSIBILITÉ DE DOUBLE ILLUMINATION SUR L'ÉTAGÈRE





DOS NIVELES DE EXPOSICIÓN REFRIGERADA  
TWO LEVELS OF REFRIGERATED EXHIBITION  
DEUX NIVEAUX D'EXPOSITION RÉFRIGÉRÉE

CRISTAL ABATIBLE  
FOLDING GLASS  
VITRE ABATTABLE

COMPONENTES DE MÁXIMA CALIDAD  
HIGHEST QUALITY COMPONENTS  
COMPOSANTS DE QUALITE MAXIMALE



**V46**

CAPACIDAD PARA 6 BANDEJAS GN 1/6 X 40 + 4 BANDEJAS 1/3 X 40  
CAPACITY FOR 6 GN 1/6X40 TRAYS + 4 GN 1/3X40 TRAYS  
CAPACITÉ POUR 6 BACS GN 1/6X 40 + 4 BACS 1/3 X 40



+2°C/+6°C

+2°C/+6°C



CRISTALES TEMPLADOS  
TEMPERED GLASS  
VITRE EN VERRE TREMPÉ

+2°C/+6°C

+2°C/+6°C

CAPACIDAD PARA 8 BANDEJAS GN 1/6 X 40 + 6 BANDEJAS 1/3 X 40  
CAPACITY FOR 8 GN 1/6X40 TRAYS + 6 GN 1/3X40 TRAYS  
CAPACITÉ POUR 8 BACS GN 1/6X 40 + 6 BACS 1/3 X 40

CUBA EMBUTIDA AISI304 SIN ÁNGULOS  
AISI304 PRESSED VAT WITHOUT ANGLES  
CUVE MARQUETÉE AISI304 SANS ANGLE

HIGH POWER LEDS EN LOS DOS PISOS  
HIGH POWER LEDS IN BOTH LEVELS  
HIGH POWER LEDS SUR LES DEUX ÉTAGES!

ZONA DE SERVICIO  
SERVICE AREA  
ZONE DE SERVICE

DOS NIVELES DE EXPOSICIÓN REFRIGERADA  
TWO LEVELS OF REFRIGERATED EXHIBITION  
DEUX NIVEAUX D'EXPOSITION RÉFRIGÉRÉE



**V68**

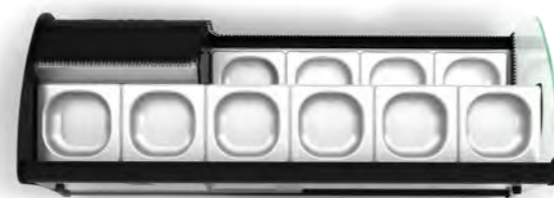

**SHARK 46 - 68**

	MEDIDAS	PROFUNDIDAD CUBA	BANDEJAS	TEMP. (FOOD ZONE)	TEMP. (ESTANTE)	DOBLE LED
<b>V46</b>	1084x395x340	40mm	INCLUIDAS	+2°C/+6°C	+2°C/+6°C	SI
<b>V68</b>	1438x395x340	40mm	INCLUIDAS	+2°C/+6°C	+2°C/+6°C	SI

MODELOS DISPONIBLES EN CUBA PLANA - AVAILABLE ALSO IN FLAT PLATE MODELS - MODÈLES DISPONIBLES EN CUVE PLANE (SANS BAC)



ESTANTE INTERMEDIO DE CRISTAL  
INTERMEDIATE GLASS SHELF  
ÉTAGÈRE INTERMÉDIAIRE EN VERRE

CRISTAL ABATIBLE  
FOLDING GLASS  
VITRE ABATTABLE

HIGH POWER LEDS

CONTROL DIGITAL  
TEMPERATURA REGULABLE  
TEMPERATURE-CONTROLLED  
TEMPÉRATURE RÉGLABLE



SHK26L

FABRICADAS EN ACERO AISI 304  
MANUFACTURED IN AISI 304 STAINLESS STEEL  
FABRIQUÉES EN ACIER INOXYDABLE AISI 304

INTERIOR DESMONTABLE PARA LIMPIEZA  
REMOVABLE INTERIOR FOR EASY CLEANING  
INTÉRIEUR DÉMONTABLE POUR LE NETTOYAGE



+90°C

BANDEJA RECOGEMIGAS  
REMOVABLE CRUMB TRAY  
BAC RAMASSE MIETTES

SHARK 2P SAHARA

	MEDIDAS	TIPO DE CALOR	BANDEJAS	POTENCIA	TEMP.(MAX)	LED
SHK24	840x395x340	SECO	SIN BANDEJAS	800W	90°C	NO
SHK26	1190x395x340	SECO	SIN BANDEJAS	1.000W	90°C	NO
SHK24L	840x395x340	SECO	SIN BANDEJAS	800W	90°C	SI
SHK26L	1190x395x340	SECO	SIN BANDEJAS	1.000W	90°C	SI

ESTANTE INTERMEDIO DE CRISTAL  
MIDDLE GLASS SHELF  
ÉTAGÈRE EN VERRE INTERMÉDIAIRE

CRISTAL ABATIBLE  
FOLDING GLASS  
PLIANTE VERRE

HIGH POWER LEDS

CONTROL DIGITAL  
TEMPERATURA REGULABLE  
TEMPERATURE-CONTROLLED  
TEMPÉRATURE RÉGLABLE



CRISTALES TEMPLADOS  
TEMPERED GLASS  
TEMPÉRÉE VERRE



+90°C

FABRICADAS EN ACERO AISI 304  
MANUFACTURED IN AISI 304  
STAINLESS STEEL  
FABRIQUÉ EN ACIER INOX 304

DESAGÜE PARA FACILITAR LA LIMPIEZA  
EASY CLEANING DRAINAGE  
ÉGOUTTER POUR UN NETTOYAGE FACILE

BANDEJAS INCLUIDAS GN 1/3 X 40  
GN 1/3 X 40 TRAYS INCLUDED  
PLATEAU INCLUS GN 1/3 X 40

SHARK 2P BAÑO MARIA

	MEDIDAS	TIPO DE CALOR	BANDEJAS	POTENCIA	TEMP. (MAX)	LED
CK24	840x395x340	BAÑO MARIA	4 GN 1/3x40	800W	90°C	NO
CK26	1190x395x340	BAÑO MARIA	6 GN 1/3x40	1.000W	90°C	NO
CK24L	840x395x340	BAÑO MARIA	4 GN 1/3x40	800W	90°C	SI
CK26L	1190x395x340	BAÑO MARIA	6 GN 1/3x40	1.000W	90°C	SI



SELF SERVICE SAHARA  
90°C

SELF SERVICE BAÑO MARÍA  
90°C

SELF SERVICE TAPAS  
+2°C / +6°C



PUERTAS DELANTERAS PARA AUTOSERVICIO  
FRONT DOORS FOR SELF SERVICE  
PORTES AVANT POUR AUTO-SERVICE

HIGH POWER LEDS

PLACA FRIA  
COLD TRAY  
PLAQUE FROIDE

+2°C/+6°C

PUERTAS TRASERAS PARA AUTOSERVICIO  
REAR DOORS FOR SELF SERVICE  
PORTES ARRIÈRE POUR AUTO-SERVICE

SENSORES OCULTOS PARA FACILITAR SU LIMPIEZA  
HIDDEN SENSORS FOR EASY CLEANING  
CAPTEURS CACHÉ POUR UN NETTOYAGE FACILE

IDEAL PARA BUFFETS AUTOSERVICIO  
IDEAL FOR SELF-SERVICE BUFFETS  
IDÉALE POUR BUFFETS SELF-SERVICE



SELF - SERVICE TAPAS

	MEDIDAS	PROFUNDIDAD CUBA	Nº PUERTAS		BANDEJA	TEMP. (FOOD ZONE)	POWER LED
			DELANTERAS	TRASERAS			
<b>S4N</b>	1085x395x245	40mm	2	2	4 GN 1/3x40	+2 /+6 °C	SI
<b>S6N</b>	1438x395x245	40mm	3	3	6 GN 1/3x40	+2 /+6 °C	SI
<b>S8N</b>	1788x395x245	40mm	4	4	8 GN 1/3x40	+2 /+6 °C	SI
<b>S0N</b>	2140x395x245	40mm	5	5	10 GN 1/3x40	+2 /+6 °C	SI
<b>S4NP</b>	1085x395x245	15mm	2	2	SIN BANDEJAS	+2 /+6 °C	SI
<b>S6NP</b>	1438x395x245	15mm	3	3	SIN BANDEJAS	+2 /+6 °C	SI
<b>S8NP</b>	1788x395x245	15mm	4	4	SIN BANDEJAS	+2 /+6 °C	SI
<b>S0NP</b>	2140x395x245	15mm	5	5	SIN BANDEJAS	+2 /+6 °C	SI

CUBA GN  
CUBA PLANA

SELF-SERVICE LINE

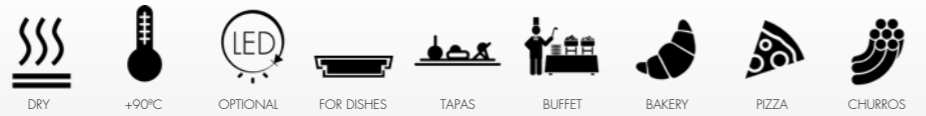

PUERTAS DELANTERAS Y TRASERAS PARA AUTOSERVICIO  
FRONT AND REAR DOORS FOR SELF-SERVICE  
PORTES AVANT ET ARRIÈRE POUR AUTO-SERVICE

BANDEJA RECOGEMIGAS  
REMOVABLE CRUMB TRAY  
SAC RECUEILLE LES MIETTES

HIGH POWER LEDS

CRISTALES TEMPLADOS  
TEMPERED GLASS  
TEMPÉRÉE VERRE

CONTROL DIGITAL  
TEMPERATURA REGULABLE  
TEMPERATURE-CONTROLLED  
TEMPÉRATURE RÉGLABLE



SHS4



SHM

INTERIOR DESMONTABLE PARA SU LIMPIEZA  
REMOVABLE INTERIOR FOR EASY CLEANING  
INTÉRIEUR DÉMONTABLE POUR LE NETTOYAGE

+++  
+90°C

SELF - SERVICE SAHARA

	MEDIDAS	TIPO DE CALOR	N° PUERTAS		POTENCIA	TEMP. (MAX)	CONTROL	
			DELANTERAS	TRASERAS			DIGITAL	LED
SHM	500x350x230	SECO	1	1	400W	60°C	NO	NO
SHS4	840x395x245	SECO	2	2	800W	90°C	SI	NO
SHS6	1190x395x245	SECO	3	3	1.000W	90°C	SI	NO
SHS4L	840x395x245	SECO	2	2	800W	90°C	SI	SI
SHS6L	1190x395x245	SECO	3	3	1.000W	90°C	SI	SI



FABRICADAS EN ACERO AISI 304  
MANUFACTURED IN AISI 304 STAINLESS STEEL  
FABRIQUÉES EN ACIER INOXYDABLE AISI 304

HIGH POWER LEDS

CRISTALES TEMPLADOS  
TEMPERED GLASS  
TEMPÉRÉE VERRE



CSS6L

PUERTAS DELANTERAS Y TRASERAS PARA AUTOSERVICIO  
FRONT AND REAR DOORS FOR SELF-SERVICE  
PORTES AVANT ET ARRIÈRE POUR AUTO-SERVICE

BANDEJAS INCLUIDAS GN 1/3 X 40  
GN 1/3 X 40 TRAYS INCLUDED  
BACS INCLUS GN 1/3X40

+++  
+90°C

DESAGÜE PARA FACILITAR SU LIMPIEZA  
EASY CLEANING DRAINAGE  
VIDANGE POUR FACILITER LE NETTOYAGE.

TEMPERATURA REGULABLE  
TEMPERATURE-CONTROLLED  
TEMPÉRATURE RÉGLABLE



SELF - SERVICE BAÑO MARIA

	MEDIDAS	TIPO DE CALOR	BANDEJAS	POTENCIA	N° PUERTAS		TEMP. (MAX)	LED
					DELANTERAS	TRASERAS		
CSS4	840x395x245	BAÑO MARIA	4 GN 1/3x40	800W	2	2	90°C	NO
CSS6	1190x395x245	BAÑO MARIA	6 GN 1/3x40	1.000W	3	3	90°C	NO
CSS4L	840x395x245	BAÑO MARIA	4 GN 1/3x40	800W	2	2	90°C	SI
CSS6L	1190x395x245	BAÑO MARIA	6 GN 1/3x40	1.000W	3	3	90°C	SI



LA VITRINA MÁS ESTRECHA DEL MERCADO  
THE NARROWEST DISPLAY CABINET IN THE MARKET  
LA VITRINE LA PLUS ÉTROITE DU MARCHÉ

HIGH POWER LEDS

GRUPO MOTOR MÁS REDUCIDO DEL MERCADO  
THE MOST REDUCED ENGINE OF THE MARKET  
GROUPE MOTEUR LE PLUS RÉDUIT DU MARCHÉ



260mm

ESTANTE INTERMEDIO DE CRISTAL  
MIDDLE GLASS SHELF  
ÉTAGÈRE INTERMÉDIAIRE EN VERRE

BANDEJAS INCLUIDAS GN 1/6 X 40  
GN 1/6 X 40 TRAYS INCLUDED  
BACS INCLUS GN 1/6 X 40

"SAYL BLUE" DIGITAL CONTROL

+2°C/+6°C



EXCLUSIVO EVAPORADOR ANTIGOTEO  
EXCLUSIVE ANTI-DRIP EVAPORATOR  
ÉVAPORATEUR EXCLUSIF ANTI-GOUTTE

CRISTALES TEMPLADOS  
TEMPERED GLASS  
VITRE EN VERRE TREMPÉ

GRUPO MOTOR MÁS REDUCIDO DEL MERCADO  
THE MOST REDUCED ENGINE OF THE MARKET  
GROUPE MOTEUR LE PLUS RÉDUIT DU MARCHÉ



+8°C / +12°C

+2°C / +6°C

PLACA FRÍA Y EVAPORADOR ESTÁTICO  
COLD TRAY AND STATIC EVAPORATOR  
PLAQUE FROIDE ET ÉVAPORATEUR STATIQUE

SLIM TAPAS - SLIM DOBLE FRIO

	MEDIDAS	ESTANTE NEUTRO	BANDEJA	TEMP. (FOOD ZONE)	TEMP. (ESTANTE)	LED
<b>VSL7</b>	1350x260x400	1130 x150	7 GN 1/6x40	+2/+6°C	NEUTRAL	SI
<b>VSL7S</b>	1350x260x400	1130 x150	7 GN 1/6x40	+2/+6°C	+8/+12°C	SI

NEW

SAYL  
LINE  
SLIM

SLIM



CRISTAL ABATIBLE PARA FACILITAR SU LIMPIEZA  
FOLDING GLASS FOR EASY CLEANING  
VITRE ABATIBLÉ POUR FACILITER LE NETTOYAGE

DISPONIBLE EN 5 COLORES ESTÁNDAR  
AVAILABLE IN 5 STANDARD COLORS  
DISPONIBLE EN 5 COLORIS STANDARD



V8N



VITRINA CON MÁXIMA VISIBILIDAD  
MAXIMUM VISIBILITY DISPLAY CABINET  
VITRINE AVEC UN MAXIMUM DE VISIBILITÉ



V4N

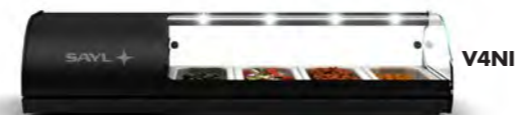

V4NI

BANDEJAS INCLUIDAS GN 1/3 X 40  
TRAYS INCLUDED GN 1/3 X 40  
BACS INCLUS GN 1/3 X 40



V4B



PLACA FRÍA Y EVAPORADOR ESTÁTICO  
COLD TRAY AND STATIC EVAPORATOR  
PLAQUE FROIDE ET L'ÉVAPORATEUR STATIQUE

SISTEMA "LIMPIEZA FÁCIL" SIN ÁNGULOS EN LA CUBA  
"EASY TO CLEAN" SYSTEM VAT WITHOUT ANGLES  
SYSTÈME "NETTOYAGE FACILE" SANS ANGLE DANS LA CUVE

EXCLUSIVO EVAPORADOR ANTIGOTEÓ  
EXCLUSIVE ANTI-DRIP EVAPORATOR  
ÉVAPORATEUR EXCLUSIF ANTI-GOUTTE

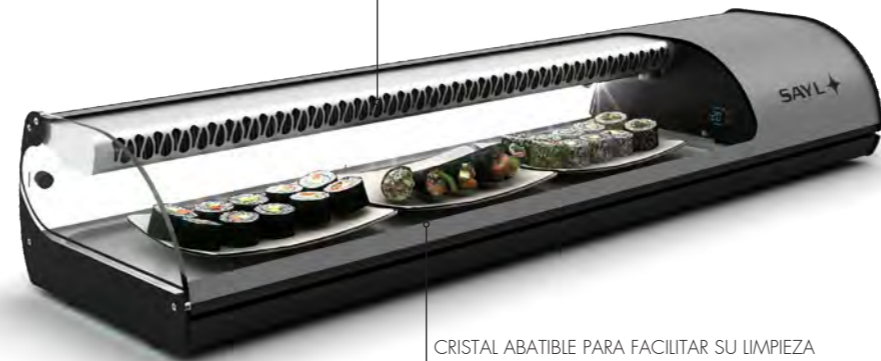

CRISTAL ABATIBLE PARA FACILITAR SU LIMPIEZA  
FOLDING GLASS FOR EASY CLEANING  
VITRE ABATIBLÉ POUR FACILITER LE NETTOYAGE

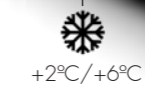

BANDEJA DE RECOGIDA DE AGUA AUTOMÁTICA  
AUTOMATIC WATER COLLECTION TRAY  
BAC DE RÉCUPÉRATION D'EAU AUTOMATIQUE



SAYL

STANDARD TAPAS

	■	■	■	■	■	MEDIDAS	PROFUNDIDAD CUBA	BANDEJA	TEMP. (FOOD ZONE)	POWER LED	
CUBA GN	V4E	V4A	V4R	V4N	V4NI	V4B	1085x395x245	40mm	4 GN 1/3x40	+2 / +6 °C	SI
	V6E	V6A	V6R	V6N	V6NI	V6B	1438x395x245	40mm	6 GN 1/3x40	+2 / +6 °C	SI
	V8E	V8A	V8R	V8N	V8NI	V8B	1788x395x245	40mm	8 GN 1/3x40	+2 / +6 °C	SI
	V10E	V10A	V10R	V10N	-	V10B	2140x395x245	40mm	10 GN 1/3x40	+2 / +6 °C	SI
	V4EP	V4AP	V4RP	V4NP	V4NPI	V4BP	1085x395x245	15mm	SIN BANDEJAS	+2 / +6 °C	SI
CUBA PLANA	V6EP	V6AP	V6RP	V6NP	V6NPI	V6BP	1438x395x245	15mm	SIN BANDEJAS	+2 / +6 °C	SI
	V8EP	V8AP	V8RP	V8NP	V8NPI	V8BP	1788x395x245	15mm	SIN BANDEJAS	+2 / +6 °C	SI
	V10EP	V10AP	V10RP	V10NP	-	V10BP	2140x395x245	15mm	SIN BANDEJAS	+2 / +6 °C	SI

STANDARD SUSHI

	■	■	■	■	■	MEDIDAS	PROFUNDIDAD CUBA	BANDEJA	TEMP. (FOOD ZONE)	POWER LED	
CUBA GN	VS4E	VS4A	VS4R	VS4N	VS4NI	VS4B	1085x395x245	40mm	4 GN 1/3x40	+2 / +6 °C	SI
	VS6E	VS6A	VS6R	VS6N	VS6NI	VS6B	1438x395x245	40mm	6 GN 1/3x40	+2 / +6 °C	SI
	VS8E	VS8A	VS8R	VS8N	VS8NI	VS8B	1788x395x245	40mm	8 GN 1/3x40	+2 / +6 °C	SI
	VS10E	VS10A	VS10R	VS10N	-	VS10B	2140x395x245	40mm	10 GN 1/3x40	+2 / +6 °C	SI
	VS4EP	VS4AP	VS4RP	VS4NP	VS4NPI	VS4BP	1085x395x245	15mm	SIN BANDEJAS	+2 / +6 °C	SI
CUBA PLANA	VS6EP	VS6AP	VS6RP	VS6NP	VS6NPI	VS6BP	1438x395x245	15mm	SIN BANDEJAS	+2 / +6 °C	SI
	VS8EP	VS8AP	VS8RP	VS8NP	VS8NPI	VS8BP	1788x395x245	15mm	SIN BANDEJAS	+2 / +6 °C	SI
	VS10EP	VS10AP	VS10RP	VS10NP	-	VS10BP	2140x395x245	15mm	SIN BANDEJAS	+2 / +6 °C	SI

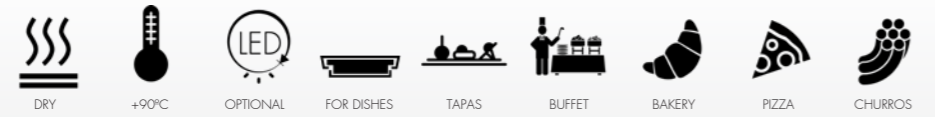

SUPERFICIE APTA PARA APOYAR PLATOS  
SURFACE SUITABLE FOR SUPPORTING PLATES  
SURFACE PERMETTANT DE POSER DES PLATS

HIGH POWER LEDS

CRISTAL ABATIBLE  
FOLDING GLASS  
PLIANTE VERRE



BANDEJA RECOGEMIGAS  
REMOVABLE CRUMB TRAY  
BAC RAMASSE MIETTES

CONTROL DIGITAL  
TEMPERATURA REGULABLE  
TEMPERATURE-CONTROLLED  
TEMPÉRATURE RÉGLABLE

+90°C

INTERIOR DESMONTABLE PARA SU LIMPIEZA  
REMOVABLE INTERIOR FOR EASY CLEANING  
INTÉRIEUR DÉMONTABLE POUR LE NETTOYAGE

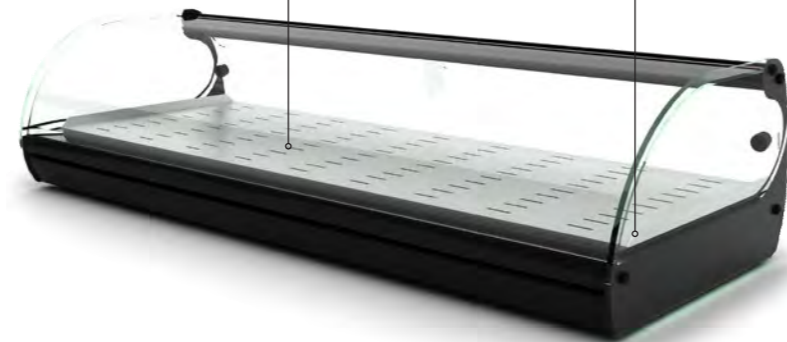

#### STANDARD SAHARA

	MEDIDAS	TIPO DE CALOR	BANDEJAS	POTENCIA	TEMP. (MAX.)	LED
<b>SH4</b>	840x395x245	SECO	SIN BANDEJAS	800W	90°C	NO
<b>SH6</b>	1190x395x245	SECO	SIN BANDEJAS	1.000W	90°C	NO
<b>SH4L</b>	840x395x245	SECO	SIN BANDEJAS	800W	90°C	SI
<b>SH6L</b>	1190x395x245	SECO	SIN BANDEJAS	1.000W	90°C	SI



HIGH POWER LEDS



CRISTALES TEMPLADOS  
TEMPERED GLASS  
VITRES EN VERRE TREMPÉ

+90°C

DESAGÜE PARA FACILITAR LA LIMPIEZA  
EASY CLEANING DRAINAGE  
VIDANGE POUR UN NETTOYAGE FACILE

FABRICADAS EN ACERO AISI 304  
MANUFACTURED IN AISI 304 STAIN-  
LESS STEEL  
FABRIQUÉ EN ACIER INOX 304

TEMPERATURA REGULABLE  
TEMPERATURE-CONTROLLED  
TEMPÉRATURE RÉGLABLE



CRISTAL ABATIBLE  
FOLDING GLASS  
VITRE ABATTABLE

BANDEJAS INCLUIDAS GN 1/3 X 40  
GN 1/3 X 40 TRAYS INCLUDED  
PLATEAU INCLUS GN 1/3 X 40

#### STANDARD BAÑO MARIA

	MEDIDAS	TIPO DE CALOR	BANDEJAS	POTENCIA
<b>C4</b>	840x395x245	BAÑO MARIA	4 GN 1/3x40	800W
<b>C6</b>	1190x395x245	BAÑO MARIA	6 GN 1/3x40	1.000W
<b>C4L</b>	840x395x245	BAÑO MARIA	4 GN 1/3x40	800W
<b>C6L</b>	1190x395x245	BAÑO MARIA	6 GN 1/3x40	1.000W



DOS PISOS SAHARA  
90°C



DOS PISOS  
BAÑO MARÍA  
90°C



DOS PISOS TAPAS  
+2°C / +6°C



V26N



V26NI



VITRINA CON MÁXIMA VISIBILIDAD  
MAXIMUM VISIBILITY DISPLAY CABINET  
VITRINE AVEC UN MAXIMUM DE VISIBILITÉ

ESTANTE INTERMEDIO DE CRISTAL  
MIDDLE GLASS SHELF  
ETAGÈRE INTERMÉDIAIRE EN VERRE

CRISTAL ABATIBLE PARA FACILITAR LA LIMPIEZA  
FOLDING GLASS FOR EASY CLEANING  
VITRE ABATTABLE POUR FACILITER LE NETTOYAGE

DISPONIBLE EN 5 COLORES ESTÁNDAR  
AVAILABLE IN 5 STANDARD COLORS  
DISPONIBLE EN 5 COLORIS STANDARD



BISAGRA FRONTAL INVISIBLE  
INVISIBLE FRONT HINGE  
CHARNIÈRE FRONTALE INVISIBLE

V28B

DISEÑADA PARA EVITAR LA EXPULSIÓN DE AIRE CALIENTE AL USUARIO O AL CLIENTE  
DESIGNED TO AVOID THE EXPULSION OF WARM AIR DIRECT TO THE CLIENT  
CONÇUE DE FAÇON À ÉVITER L'EXPULSION DE L'AIR CHAUD SUR L'UTILISATEUR ET SUR LE CLIENT.

+2°C / +6°C

DOS PISOS TAPAS

CUBA PLANA	CUBA GN	Color						MEDIDAS	CUBA	ESTANTE	BANDEJA	TEMP. (FOOD ZONE)	TEMP. ESTANTE	LED
		■	■	■	■	■	■							
V24E	V24A	V24R	V24N	V24NI	V24B	1085x395x360	40mm	720x195	4 GN 1/3x40	+2 / +6 °C	NEUTRO	SI		
V26E	V26A	V26R	V26N	V26NI	V26B	1438x395x360	40mm	1075x195	6 GN 1/3x40	+2 / +6 °C	NEUTRO	SI		
V28E	V28A	V28R	V28N	V28NI	V28B	1788x395x360	40mm	1425x195	8 GN 1/3x40	+2 / +6 °C	NEUTRO	SI		
V24EP	V24AP	V24RP	V24NP	V24NIP	V24BP	1085x395x360	15mm	720x195	SIN BANDEJAS	+2 / +6 °C	NEUTRO	SI		
V26EP	V26AP	V26RP	V26NP	V26NIP	V26BP	1438x395x360	15mm	1075x195	SIN BANDEJAS	+2 / +6 °C	NEUTRO	SI		
V28EP	V28AP	V28RP	V28NP	V28NIP	V28BP	1788x395x360	15mm	1425x195	SIN BANDEJAS	+2 / +6 °C	NEUTRO	SI		

\*POSIBILIDAD DE ILUMINACIÓN EN EL ESTANTE (DOBLE ILUMINACIÓN) OPCIONAL - POSSIBILITY OF LIGHTING ON THE SHELF (DOUBLE ILLUMINATION) OPTIONAL - EN OPTION : POSSIBILITÉ DE DOUBLE ILLUMINATION SUR L'ÉTAGÈRE



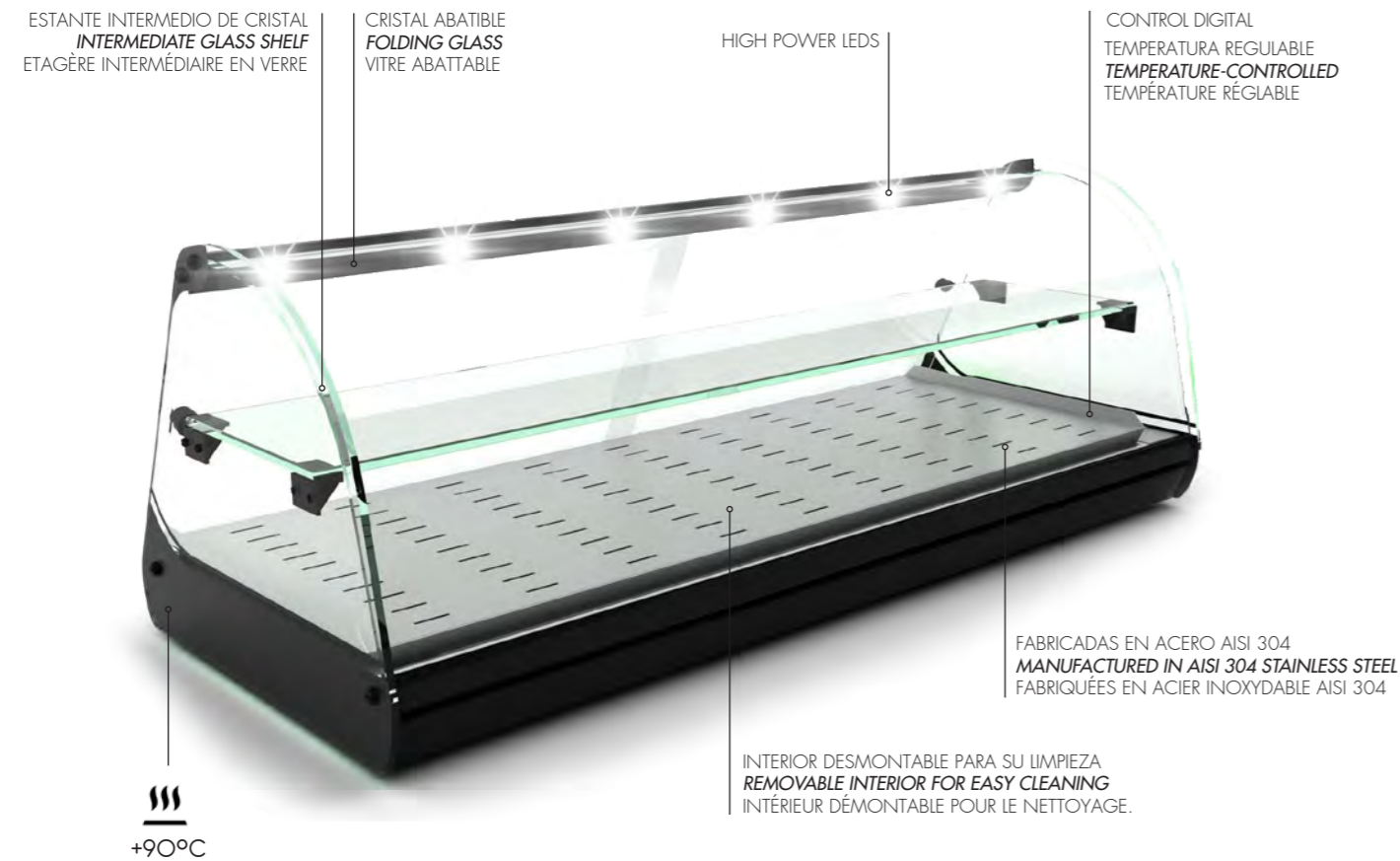
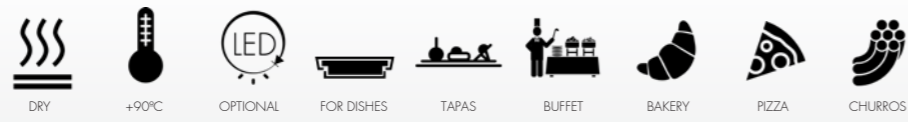

#### DOS PISOS - SAHARA

	MEDIDAS	TIPO DE CALOR	BANDEJAS	POTENCIA	TEMP.(MAX)	LED
<b>SH24</b>	840x395x360	SECO	SIN BANDEJAS	800W	90°C	NO
<b>SH26</b>	1190x395x360	SECO	SIN BANDEJAS	1.000W	90°C	NO
<b>SH24L</b>	840x395x360	SECO	SIN BANDEJAS	800W	90°C	SI
<b>SH26L</b>	1190x395x360	SECO	SIN BANDEJAS	1.000W	90°C	SI



#### DOS PISOS - BAÑO MARIA

	MEDIDAS	TIPO DE CALOR	BANDEJAS	POTENCIA	TEMP. (MAX)	LED
<b>C24</b>	840x395x360	BAÑO MARIA	4 GN 1/3x40	800W	90°C	NO
<b>C26</b>	1190x395x360	BAÑO MARIA	6 GN 1/3x40	1.000W	90°C	NO
<b>C24L</b>	840x395x360	BAÑO MARIA	4 GN 1/3x40	800W	90°C	SI
<b>C26L</b>	1190x395x360	BAÑO MARIA	6 GN 1/3x40	1.000W	90°C	SI



SAYL

GRUPO REMOTO



NEW

COMBINABLES CON LOS CALENTADORES Y NEUTROS DEL MISMO MODELO  
 COMBINABLES AVEC LES VITRINES CHAUDES/NEUTRE DU MÊME MODÈLE  
 COMBINABLE WITH SAME MODELS HEATED/NEUTRAL DISPLAY CASES

POSIBILIDAD DE CUBA PLANA EN TODOS LOS MODELOS  
 POSSIBILITÉ DE CUVE PLANE SANS BAC DANS TOUS LES MODÈLE ALL MODELS ALSO AVAILABLE IN FLAT VAT

IDEAL PARA INTEGRAR EN LA DECORACIÓN  
 IDÉAL POUR INTÉGRER DANS LA DÉCORATION  
 PERFECT TO INTEGRATE IN YOUR DECORATION



TERMOSTATO EN ZONA DE USO  
 THERMOSTAT DANS LA ZONE DE TRAVAIL  
 THERMOSTAT IN THE WORK AREA

2m

POSIBILIDAD DE SALIDA DE TUBERIAS EN LADO CONTRARIO  
 POSSIBILITÉ DE LA SORTIE DU TUBE DE L'AUTRE CÔTÉ  
 POSSIBILITY OF EXIT PIPE ON BOTH SIDES

+2°C/+6°C  
 FOOD ZONE

GRUPO FRIGORÍFICO OPCIONAL EN TODOS LOS MODELO  
 GROUPE FRIGORIFIQUE EN OPTION DANS TOUS LES MODÈLES  
 OPTIONAL REFRIGERATION UNIT IN ALL MODELS

LOGIC TRIPLE - GRUPO REMOTO

	MEDIDAS	CUBA	BANDEJAS	TEMP.	LED
<b>VTLG24GR</b>	825x385x460	40mm	4 GN 1/3x40	+2/+6°C	SI
<b>VTLG26GR</b>	1175x385x460	40mm	6 GN 1/3x40	+2/+6°C	SI
<b>VTLG28GR</b>	1540x385x460	40mm	8 GN 1/3x40	+2/+6°C	SI
<b>VTLG24GRP</b>	840x385x460	15mm	CUBA PLANA	+2/+6°C	SI
<b>VTLG26GRP</b>	1175x385x460	15mm	CUBA PLANA	+2/+6°C	SI
<b>VTLG28GRP</b>	1540x385x460	15mm	CUBA PLANA	+2/+6°C	SI

### STANDARD GRUPO REMOTO

	MEDIDAS	CUBA	BANDEJAS	TEMP.	LED
<b>V4GR</b>	840x395x245	40mm	4 GN 1/3x40	+2/+6°C	SI
<b>V6GR</b>	1190x395x245	40mm	6 GN 1/3x40	+2/+6°C	SI
<b>V4GRP</b>	840x395x245	15mm	SIN BANDEJAS	+2/+6°C	SI
<b>V6GRP</b>	1190x395x245	15mm	SIN BANDEJAS	+2/+6°C	SI



### DOS PISOS GRUPO REMOTO

	MEDIDAS	CUBA	BANDEJAS	TEMP.	LED
<b>V24GR</b>	840x395x360	40mm	4 GN 1/3x40	+2/+6°C	SI
<b>V26GR</b>	1190x395x360	40mm	6 GN 1/3x40	+2/+6°C	SI
<b>V24GRP</b>	840x395x360	15mm	SIN BANDEJAS	+2/+6°C	SI
<b>V26GRP</b>	1190x395x360	15mm	SIN BANDEJAS	+2/+6°C	SI



### LOGIC GRUPO REMOTO

	MEDIDAS	CUBA	BANDEJAS	TEMP.	LED
<b>VTLG4GR</b>	850x385x225	40mm	4 GN 1/3x40	+2/+6°C	SI
<b>VTLG6GR</b>	1175x385x225	40mm	6 GN 1/3x40	+2/+6°C	SI
<b>VTLG8GR</b>	1540x385x225	40mm	8 GN 1/3x40	+2/+6°C	SI
<b>VTLG4GRP</b>	850x385x225	15mm	SIN BANDEJAS	+2/+6°C	SI
<b>VTLG6GRP</b>	1175x385x225	15mm	SIN BANDEJAS	+2/+6°C	SI
<b>VTLG8GRP</b>	1540x385x225	15mm	SIN BANDEJAS	+2/+6°C	SI

### SHARK GRUPO REMOTO

	MEDIDAS	CUBA	BANDEJAS	TEMP.	LED
<b>SK4GR</b>	840x395x270	40mm	4 GN 1/3x40	+2/+6°C	SI
<b>SK6GR</b>	1190x395x270	40mm	6 GN 1/3x40	+2/+6°C	SI
<b>SK4GRP</b>	840x395x270	15mm	SIN BANDEJAS	+2/+6°C	SI
<b>SK6GRP</b>	1190x395x270	15mm	SIN BANDEJAS	+2/+6°C	SI



### SHARK DOS PISOS GRUPO REMOTO

	MEDIDAS	CUBA	BANDEJAS	TEMP.	LED
<b>SK24GR</b>	840x395x340	40mm	4 GN 1/3x40	+2/+6°C	SI
<b>SK26GR</b>	1190x395x340	40mm	6 GN 1/3x40	+2/+6°C	SI
<b>SK24GRP</b>	840x395x340	15mm	SIN BANDEJAS	+2/+6°C	SI
<b>SK26GRP</b>	1190x395x340	15mm	SIN BANDEJAS	+2/+6°C	SI

### SELF SERVICE GRUPO REMOTO

	MEDIDAS	CUBA	BANDEJAS	TEMP.	LED
<b>S4GR</b>	825x395x245	40mm	4 GN 1/3x40	+2/+6°C	SI
<b>S6GR</b>	1175x395x245	40mm	6 GN 1/3x40	+2/+6°C	SI
<b>S8GR</b>	1540x395x245	40mm	8 GN 1/3x40	+2/+6°C	SI
<b>S4GRP</b>	840x395x245	15mm	SIN BANDEJAS	+2/+6°C	SI
<b>S6GRP</b>	1175x395x245	15mm	SIN BANDEJAS	+2/+6°C	SI
<b>S8GRP</b>	1540x395x245	15mm	SIN BANDEJAS	+2/+6°C	SI





**D-2B**



SAYL

**CUBAS DROP-IN**

**CUBAS DROP - IN**

	MEDIDAS CUBA	MEDIDAS ENCASTE (A x B)	MEDIDA MAX. SOBRE (C)	CAPACIDAD GN	PROFUNDIDAD CUBA	TEMP. (FOOD ZONE)	GRUPO REMOTO
<b>D-4B</b>	700x310x40	740x350	90mm	4GN 1/3-40	40mm	+4°C/+8°C	OPCIONAL
<b>D-6B</b>	1050x310x40	1095x350	90mm	6GN 1/3-40	40mm	+4°C/+8°C	OPCIONAL
<b>D-8B</b>	1400x310x40	1445x350	90mm	8GN 1/3-40	40mm	+4°C/+8°C	OPCIONAL
<b>D-4BP</b>	700x310x15	740x350	90mm	4GN 1/3-40	15mm	+4°C/+8°C	OPCIONAL
<b>D-6BP</b>	1050x310x15	1095x350	90mm	6GN 1/3-40	15mm	+4°C/+8°C	OPCIONAL
<b>D-8BP</b>	1400x310x15	1445x350	90mm	8GN 1/3-40	15mm	+4°C/+8°C	OPCIONAL
<b>D-2B</b>	665x540x65	695x570	90mm	2GN 1/1-65	65mm	+4°C/+8°C	OPCIONAL
<b>D-3B</b>	990x540x65	1020x570	90mm	3GN 1/1-65	65mm	+4°C/+8°C	OPCIONAL
<b>D-2BP</b>	665x540x20	695x570	90mm	2GN 1/1-65	20mm	+4°C/+8°C	OPCIONAL
<b>D-3BP</b>	990x540x20	1020x570	90mm	3GN 1/1-65	20mm	+4°C/+8°C	OPCIONAL

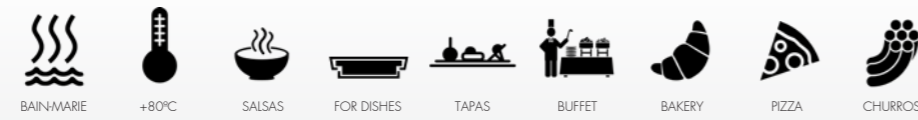

BANDEJAS INCLUIDAS GN 1/3 X 40  
GN 1/3 X 40 TRAYS INCLUDED  
PLATEAU INCLUS GN 1/3 X 40

CONTROL DIGITAL  
TEMPERATURA REGULABLE  
TEMPERATURE-CONTROLLED  
TEMPÉRATURE RÉGLABLE

FABRICADAS EN ACERO AISI 304  
MANUFACTURED IN  
AISI304 STAINLESS STEEL  
FABRIQUÉ EN ACIER INOX 304

DESAGÜE PARA FACILITAR SU LIMPIEZA  
EASY CLEANING DRAINAGE  
ÉGOUTTER POUR UN NETTOYAGE FACILE

+80°C

FABRICADAS EN ACERO AISI 304  
MANUFACTURED IN AISI304 STAINLESS STEEL  
FABRIQUÉ EN ACIER INOX 304

CONTROL DIGITAL  
TEMPERATURA REGULABLE  
TEMPERATURE-CONTROLLED  
TEMPÉRATURE RÉGLABLE

DESAGÜE PARA FACILITAR SU LIMPIEZA  
EASY CLEANING DRAINAGE  
ÉGOUTTER POUR UN NETTOYAGE FACILE

+80°C

#### BASES CALIENTES - BAÑO MARIA

	MEDIDAS	TIPO DE CALOR	BANDEJAS	POTENCIA	TEMP. (MAX)	LED
<b>C4Z</b>	840x395x80	BAÑO MARIA	4 GN 1/3x40	800W	80°C	NO
<b>C6Z</b>	1190x395x80	BAÑO MARIA	6 GN 1/3x40	1.000W	80°C	NO

#### BASES CALIENTES - SAHARA

	MEDIDAS	TIPO DE CALOR	BANDEJAS	POTENCIA	TEMP. (MAX)	LED
<b>C4ZS</b>	840x395x80	SECO	NO	800W	80°C	NO
<b>C6ZS</b>	1190x395x80	SECO	NO	1.000W	80°C	NO

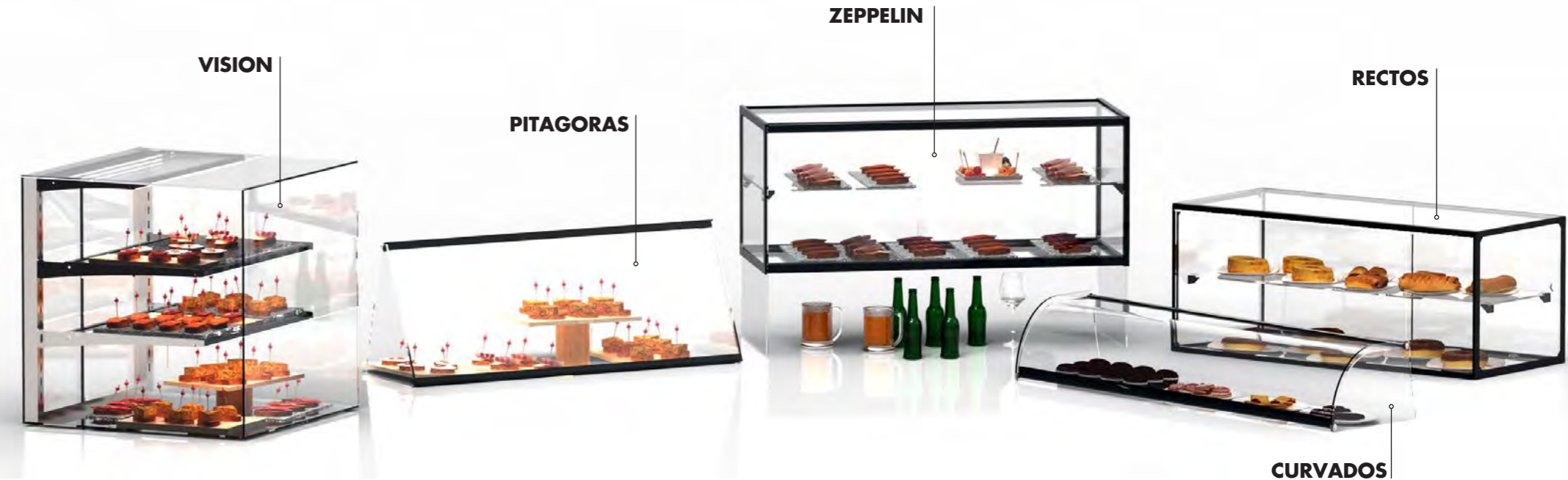
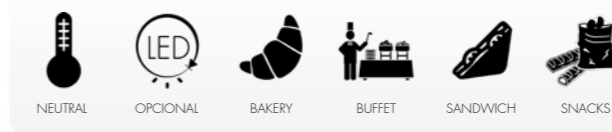

PERFIL PROTECTOR DE CRISTAL  
GLASS PROTECTOR PROFILE  
PROFILÉ PROTECTEUR DE LA VITRE



MEJOR CON ILUMINACIÓN!  
BETTER WITH LIGHTING!  
MIEUX AVEC L'ÉCLAIRAGE!



SERIGRAFÍA VITRIFICADA  
VITRIFIED SCREENPRINT  
ÉCRAN VITRIFIÉ



CRISTALES TEMPLADOS  
TEMPERED GLASS  
VITRES EN VERRE TREMPÉ

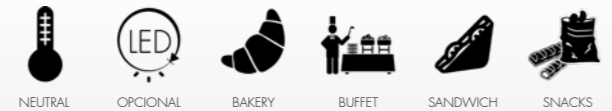

ES4

840X380X170



ES6

1190X380X170

EXPOSITORES NEUTROS PITAGORAS

	MEDIDAS	BASE	ESTANTES	CRISTALES TEMPLADOS	PUERTAS TRASERAS	LED
<b>ESR36-S</b>	555X340X240	NO	NO	SI	NO	NO
<b>ESR36-M</b>	920X340X240	NO	NO	SI	NO	NO
<b>ESR36-L</b>	1120X340X240	NO	NO	SI	NO	NO

	MEDIDAS	BASE	ESTANTES	CRISTALES TEMPLADOS	PUERTAS TRASERAS	LED
<b>ES4</b>	840X380X170	NO	NO	SI	NO	NO
<b>ES6</b>	1190X380X170	NO	NO	SI	NO	NO

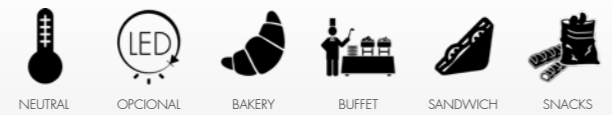

E6L  
1190X380X170



E6L  
1190X380X170



E26L  
1190X380X290  
ESTANTE : 1175X195



E26L  
1190X380X290  
ESTANTE : 1175X195

EXPOSITORES NEUTROS CRISTAL CURVADO

	MEDIDAS	ESTANTES	CRISTALES		LED
			TEMPLADOS	PUERTAS TRASERAS	
<b>E4</b>	840X380X170	NO	SI	SI	NO
<b>E4L</b>	840X380X170	NO	SI	SI	SI
<b>E6</b>	1190X380X170	NO	SI	SI	NO
<b>E6L</b>	1190X380X170	NO	SI	SI	SI



EXPOSITORES NEUTROS CRISTAL CURVADO CON ESTANTE

	MEDIDAS	ESTANTES	CRISTALES		LED
			TEMPLADOS	PUERTAS TRASERAS	
<b>E24</b>	840X380X290	825X195	SI	SI	NO
<b>E24L</b>	840X380X290	825X195	SI	SI	SI
<b>E26</b>	1190X380X290	1175X195	SI	SI	NO
<b>E26L</b>	1190X380X290	1175X195	SI	SI	SI





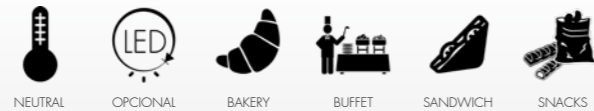

EL PRIMER EXPOSITOR VOLADOR PARA NO RENUNCIAR A LA BARRA  
**TEMPERED GLASS**  
 VITRES EN VERRE TREMPÉ



CRISTALES TEMPLADOS  
**TEMPERED GLASS**  
 VITRES EN VERRE TREMPÉ

ZONA LIBRE  
**FREE ZONE**  
 ZONE LIBRE



PERFIL PROTECTOR DE CRISTAL  
**GLASS PROTECTOR PROFILE**  
 PROFILÉ PROTECTEUR DE LA VITRE

BASE CRISTALES TEMPLADOS  
**BASE TEMPERED GLASS**  
 BASE VERRE TREMPÉ

**E36LP-M**  
 920X390X635  
 ESTANTE : 900X300

**EXPOSITORES NEUTROS ZEPPELIN - CON ESTANTE Y PASAPLATOS**



	MEDIDAS	ESTANTES	MONTADO	CRISTALES TEMPLADOS	PUERTAS TRASERAS	LED
<b>EP36Z-S</b>	555X390X635	300X535	NO	SI	SI	NO
<b>EP36LZ-S</b>	555X390X635	300X535	NO	SI	SI	SI
<b>EP36Z-M</b>	920X390X635	300X900	NO	SI	SI	NO
<b>EP36LZ-M</b>	920X390X635	300X900	NO	SI	SI	SI

Opción de doble puerta para autoservicio en todos los modelos.  
 Self-service double door option in all models.  
 Option pour tous les modèles d'une double porte pour self service.

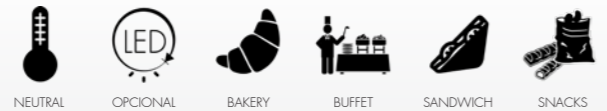

**EP30**  
920X330X315  
ESTANTE :200X900



CRISTALES TEMPLADOS  
TEMPERED GLASS  
VITRES EN VERRE TREMPÉ

**EP20**  
920X330X215

LATERALES DE CRISTAL TEMPLADO CON PINTURA VITRIFICADA  
TEMPERED GLASS LATERAL WITH VITRIFIED PAINT  
LATERAUX EN VERRE TREMPÉ AVEC PEINTURE VITRIFIÉE

POSIBILIDAD DE SERVIR DESMONTADOS CON SU MALETA DE TRANSPORTE  
IT CAN BE SERVED UNASSEMBLED IN A TRANSPORT CASE  
POSSIBILITÉ D'ÊTRE FOURNIS DÉMONTÉS DANS UNE MALETTE DE TRANSPORT



#### EXPOSITORES NEUTROS CRISTAL RECTO 1 PISO

	MEDIDAS	ESTANTES	MONTADO	CRISTALES TEMPLADOS	PUERTAS TRASERAS	LED
<b>EP20-S</b>	555X330X215	NO	NO	SI	SI	NO
<b>EP20L-S</b>	555X330X215	NO	NO	SI	SI	SI
<b>EP20-M</b>	920X330X215	NO	NO	SI	SI	NO
<b>EP20L-M</b>	920X330X215	NO	NO	SI	SI	SI
<b>EP20-B</b>	1820X330X215	NO	SI	SI	SI	NO
<b>EP20L-B</b>	1820X330X215	NO	SI	SI	SI	SI

Opción de doble puerta para autoservicio en todos los modelos.  
Self-service double door option in all models.  
Option pour tous les modèles d'une double porte pour self service.

**EP10**  
550X390X375  
ESTANTE :300X535

PERFIL PROTECTOR DE CRISTAL  
GLASS PROTECTOR PROFILE  
PROFILÉ PROTECTEUR DE LA VITRE



**EP36**  
920X390X375  
ESTANTE :300X900



AMPLIA SUPERFICIE SUPERIOR PLANA  
FLAT TOP SURFACE  
SURFACE SUPÉRIEURE PLANE



VITRINA CON LA MÁXIMA VISIBILIDAD  
MAXIMUM VISIBILITY DISPLAY CABINET  
VITRINE AVEC UN MAXIMUM DE VISIBILITÉ

#### EXPOSITORES NEUTROS CRISTAL RECTO 2P

	MEDIDAS	ESTANTES	MONTADO	CRISTALES TEMPLADOS	PUERTAS TRASERAS	LED
<b>EP36-S</b>	555X390X375	300X535	NO	SI	SI	NO
<b>EP36L-S</b>	555X390X375	300X535	NO	SI	SI	SI
<b>EP30-M</b>	920X330X315	200X900	NO	SI	SI	NO
<b>EP30L-M</b>	920X330X315	200X900	NO	SI	SI	SI
<b>EP36-M</b>	920X390X375	300X900	NO	SI	SI	NO
<b>EP36L-M</b>	920X390X375	300X900	NO	SI	SI	SI
<b>EP36-B</b>	1820X390X375	300X900 (x2)	SI	SI	SI	NO
<b>EP36L-B</b>	1820X390X375	300X900 (x2)	SI	SI	SI	SI

Opción de doble puerta para autoservicio en todos los modelos.  
Self-service double door option in all models.  
Option pour tous les modèles d'une double porte pour self service.

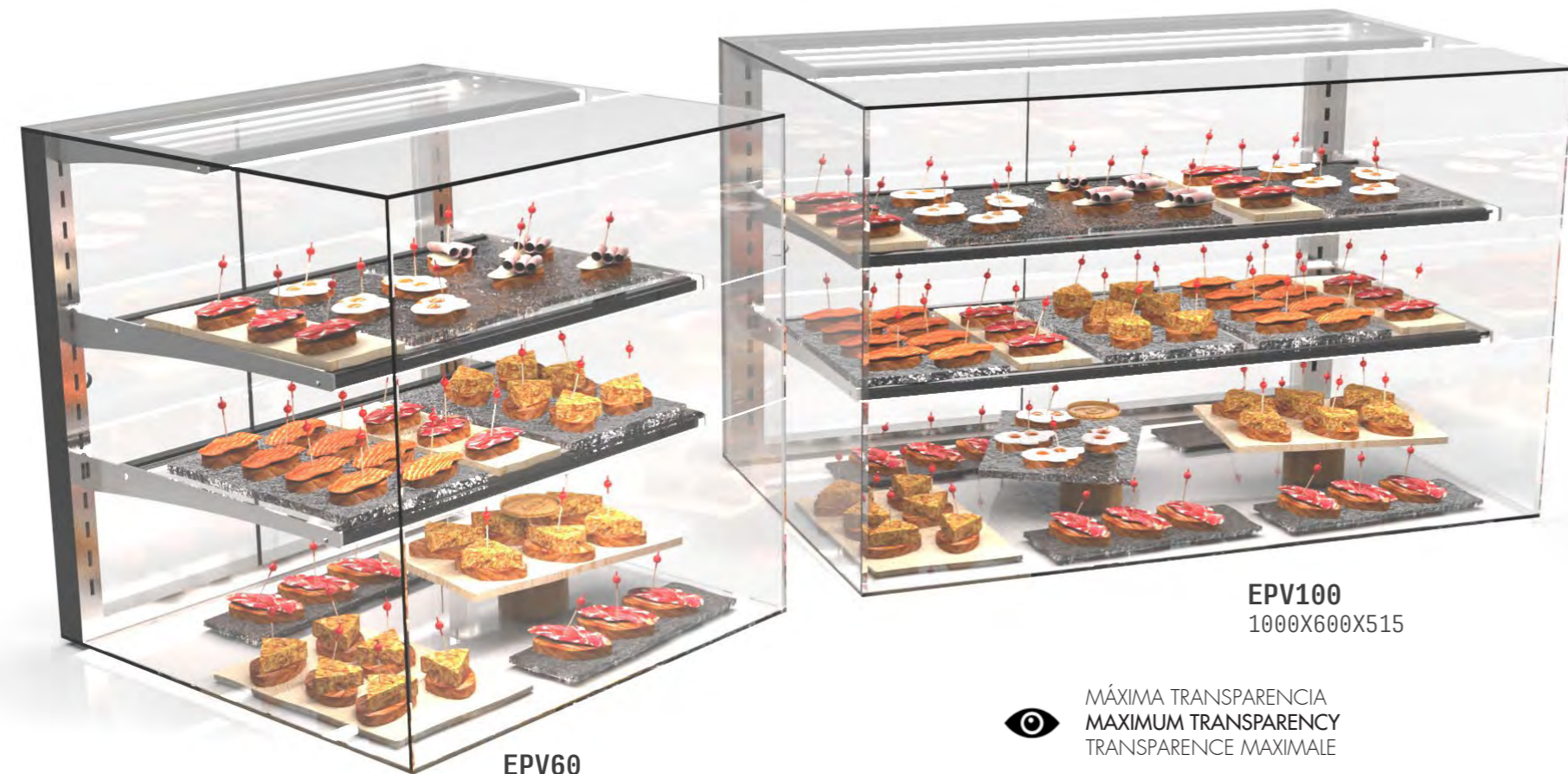
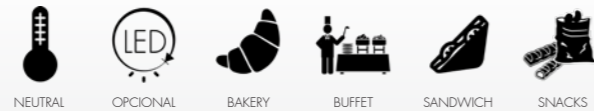

**EPV60**  
600X600X515

**EPV100**  
1000X600X515

 MÁXIMA TRANSPARENCIA  
MAXIMUM TRANSPARENCY  
TRANSPARENCE MAXIMALE

Cristales completamente limpios de estructuras para conseguir una la máxima visión del producto sin interferencias.

*The product is illuminated from two light lines to achieve perfect illumination of the product without undesirable shadows*

Vitres sans structure afin d'obtenir un maximum de visibilité du produit sans interférence.

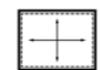

HABITABILIDAD REGULABLE  
ADJUSTABLE HABITABILITY  
HABITACLE RÉGLABLE

Grandes estantes de cristal templado regulables que permiten aumentar la habitabilidad del espacio interior al máximo

*The product is illuminated from two light lines to achieve perfect illumination of the product without undesirable shadows*

Grandes étagères réglables en verre trempé  
ermettant d'augmenter au maximum l'habitacle de l'espace intérieur



DOBLE LED EN CADA ALTURA  
DOUBLE LED AT EVERY HEIGHT  
DOUBLE LED A CHAQUE ÉTAGE

Se ilumina el producto desde dos líneas de luz para conseguir una perfecta iluminación del producto sin sombras indeseables.

*The product is illuminated from two light lines to achieve perfect illumination of the product without undesirable shadows*

Les produits sont éclairés par deux lignes de lumière luz afin d'obtenir une parfaite illumination des produits sans ombres indésirables

**EXPOSITORES VISION**

	MEDIDAS	ESTANTES	BASE	CRISTALES TEMPLADOS	PUERTAS CRISTAL	DOBLE LED
<b>EPV60</b>	600X600X515	500X400	NO	SI	SI	SI
<b>EPV100</b>	1000X600X515	900X400	NO	SI	SI	SI

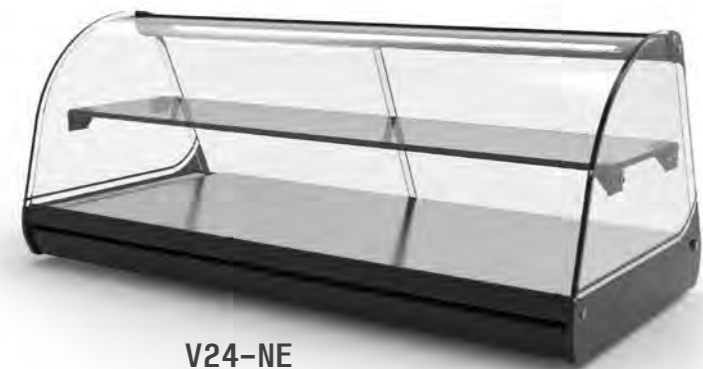

**V24-NE**  
840X395X360



**V4-NE**  
840X395X245



**SK6-NE**  
1190X395X270



**SK26-NE**  
1190X395X340

ES

Tanto si ya tienes una vitrina de tapas o sushi Sayl y quieres ampliar la línea o si quieres exponer producto neutro combinado con frío y/o caliente, estos expositores son tú mejor opción para obtener la máxima integración.

EN

Whether you already have a SAYL showcase of tapas or sushi and want to expand the line, or if you want to display a neutral product combined with cold and / or hot, these displays are the best option for maximum integration.

FR

Si vous avez déjà une vitrine à tapas ou sushi Sayl et que vous désirez agrandir la ligne ou exposer des produits neutres combinés avec du froid et du chaud, ces vitrines sont votre meilleure option pour obtenir une intégration maximale.

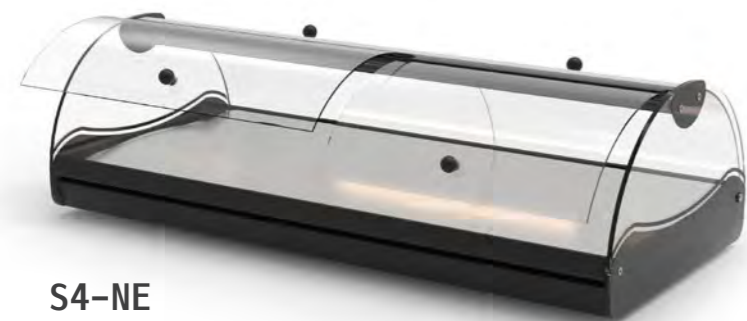

**S4-NE**  
825X395X245



**VTLG6-NE**  
1175X395X245

**EXPOSITORES NEUTROS TAPAS**

	FAMILIA	MEDIDAS	CRISTAL	ESTANTES	ACCESO DELANTERO	ACCESO TRASERO	VERSIÓN FRÍA	VERSIÓN CT
<b>VTLG4-NE</b>	LOGIC	825x385x225	PLANO	NO	NO	SI		
<b>VTLG6-NE</b>	LOGIC	1175x385x225	PLANO	NO	NO	SI	PAG. 120	PAG. 122
<b>VTLG8-NE</b>	LOGIC	1540x385x225	PLANO	NO	NO	SI		
<b>VTLG24-NE</b>	LOGIC TRIPLE	840x385x460	PLANO	SI	NO	SI		
<b>VTLG26-NE</b>	LOGIC TRIPLE	1175x385x460	PLANO	SI	NO	SI	PAG. 130	PAG. 133
<b>VTLG28-NE</b>	LOGIC TRIPLE	1540x385x460	PLANO	SI	NO	SI		
<b>V4-NE</b>	STANDARD	840x395x245	CURVADO	NO	NO	SI	PAG. 154	PAG. 140
<b>V6-NE</b>	STANDARD	1190x395x245	CURVADO	NO	NO	SI		
<b>V24-NE</b>	DOS PISOS	840x395x360	CURVADO	SI	NO	SI	PAG. 159	PAG. 160
<b>V26-NE</b>	DOS PISOS	1190x395x360	CURVADO	SI	NO	SI		
<b>SK4-NE</b>	SHARK	840x395x270	CURVADO	NO	NO	SI	PAG. 138	PAG. 140
<b>SK6-NE</b>	SHARK	1190x395x270	CURVADO	NO	NO	SI		
<b>SK24-NE</b>	SHARK 2P	840x395x340	CURVADO	SI	NO	SI	PAG. 142	PAG. 146
<b>SK26-NE</b>	SHARK 2P	1190x395x340	CURVADO	SI	NO	SI		
<b>S4-NE</b>	SELF-SERVICE	825x395x245	CURVADO	NO	SI	SI		
<b>S6-NE</b>	SELF-SERVICE	1175x395x245	CURVADO	NO	SI	SI	PAG. 148	PAG. 150
<b>S8-NE</b>	SELF-SERVICE	1540x395x245	CURVADO	NO	SI	SI		

### ISÓSCELES 710



COMPATIBILIDAD  
COMPATIBILITY  
COMPATIBILITÉ

VT XL 2B  
VT BLOCK 2B  
CT SPLENDID 2B  
CT MAXISELF 2B  
VITRINA BUFFET  
TOWER  
QBO

### ISÓSCELES 1200

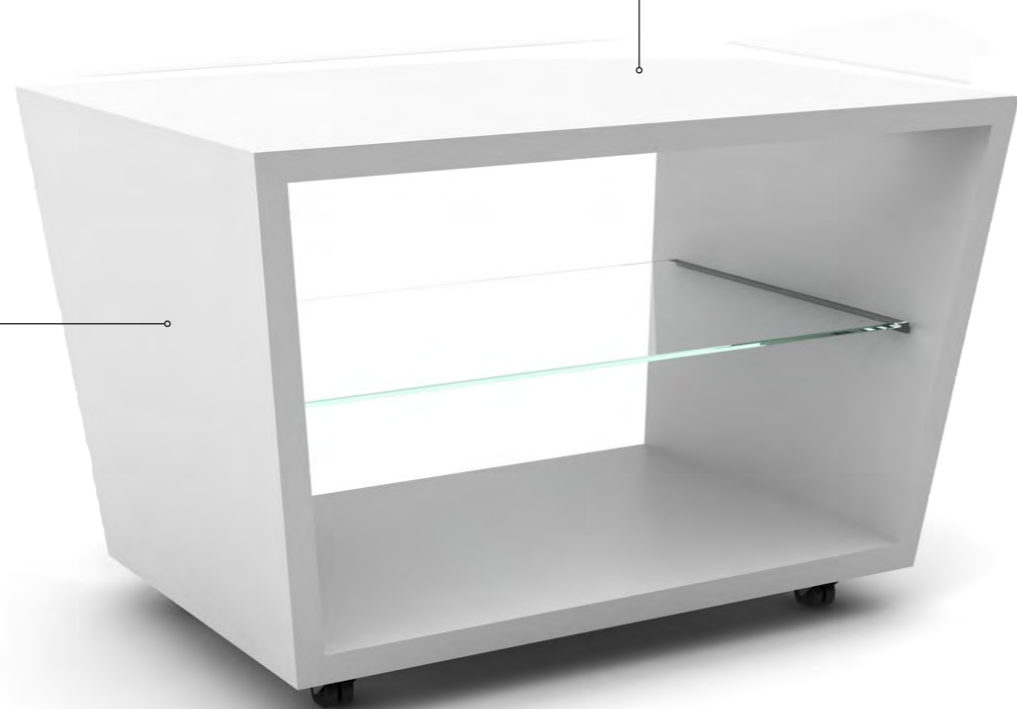

COMPATIBILIDAD  
COMPATIBILITY  
COMPATIBILITÉ

VT XL 3B  
VT BLOCK 3B  
VT MAXISELF 3B  
VT MAXISELF 2B  
VT SPLENDID 3B  
VT SPLENDID 2B  
CT SPLENDID 3B  
CT MAXISELF 3B  
VT HONDA



HONDA + ISÓSCELES 1200



QBO + ISÓSCELES 710



XL2B + ISÓSCELES 710



XL 3B + ISÓSCELES 1200



CT MAXISELF 3B + ISÓSCELES 1200

	MEDIDAS	ESTANTES	RUEDAS	CRISTALES TEMPLADOS
<b>ISÓSCELES 710</b>	710X850X775	SI	SI	SI
<b>ISÓSCELES 1200</b>	1200X850X775	SI	SI	SI

\*SE SIRVEN DESMONTADAS - ARE SERVED DISASSEMBLED - SONT SERVIS DÉMONTÉS



VITRINAS VERTICALES

RESISTENCIA ANTICONDENSACIÓN  
ANTICONDENSATION HEATING RESISTANCE  
RÉSISTANCE ANTI-CONDENSATION

FABRICADAS EN ACERO INOX AISI 304  
MANUFACTURED IN AISI 304 STAINLESS STEEL  
FABRIQUÉES EN ACIER INOX AISI304

CIERRE AUTOMÁTICO  
SELF-CLOSING  
FERMETURE AUTOMATIQUE

PUERTAS REVERSIBLES  
REVERSIBLE DOORS  
PORTES REVERSIBLES

CONTROL DIGITAL  
DIGITAL CONTROL  
CONTROLE DIGITAL

EXPOSICIÓN 4 LADOS  
4 SIDES DISPLAY  
EXPOSITION SUR LES 4 CÔTÉS

5 ESTANTES REGULABLES  
5 ADJUSTABLE SHELVES  
5 ÉTAGÈRES RÉGLABLES

DOBLE CRISTAL CAMARA  
DOUBLE GLAZED WINDOWS  
DOUBLE VITRAGE

TRIPLE CRISTAL CAMARA  
TRIPLE GLAZED WINDOWS  
TRIPLE VITRAGE

+5°C / +15°C  
-14°C / -24°C



VITRINAS VERTICALES



AVV6P

**VITRINAS VERTICALES - PASTERIA**

	TIPO	RANGO	TIPO	REFRIGERANTE	DIMENSIONES	PESO	ESTANTES	PUERTA	TIPO ESTANTES	POTENCIA	VOLTAJE	RUEDAS	VOLUMEN	TERMOSTATO	LED
<b>AVV6P</b>	POSITIVO	+5°C / +15°C	VENTILADA	R290a	620x660x1960	195KG	5	CRISTAL	REGULABLES	650 W	230V-50HZ	SI	420 LT	DIGITAL	SI
<b>AVV6N</b>	NEGATIVO	-14°C / -24°C	ESTÁTICA	R290a	620x660x1960	195KG	6	CRISTAL	ESTATICOS	700 W	230V-50HZ	SI	420 LT	DIGITAL	SI
<b>AVV12P</b>	POSITIVO	+5°C / +15°C	VENTILADA	R290a	1250x660x1960	390KG	5	CRISTAL	REGULABLES	1.300 W	230V-50HZ	SI	900 LT	DIGITAL	SI
<b>AVV12N</b>	NEGATIVO	-14°C / -24°C	ESTÁTICA	R290a	1250x660x1960	390KG	6	CRISTAL	ESTATICOS	1.400 W	230V-50HZ	SI	900 LT	DIGITAL	SI

PARA OTROS MEDIDAS Y ACABADOS , CONSULTAR DISPONIBILIDAD. - CHECK AVAILABILITY FOR OTHER MEASURES AND FINISHINGS - POUR AUTRES DIMENSIONS OU FINITIONS, CONSULTER LA DISPONIBILITÉ.



VITRINAS VERTICALES

RESISTENCIA ANTICONDENSACIÓN  
ANTICONDENSATION HEATING RESISTANCE  
RÉSISTANCE ANTI-CONDENSATION

DOBLE CRISTAL CAMRA  
DOUBLE GLAZED WINDOWS  
DOUBLE VITRAGE

CIERRE AUTOMÁTICO  
SELF-CLOSING  
FERMETURE AUTOMATIQUE

PUERTAS REVERSIBLES  
REVERSIBLE DOORS  
PORTES REVERSIBLES

LAMPARA UV - GERMICIDA  
UV LAMP - GERMICIDAL  
LAMPE UV - GERMICIDAL

CONTROL DIGITAL  
DIGITAL CONTROL  
CONTROLE DIGITAL

EXPOSICIÓN 4 LADOS  
4 SIDES DISPLAY  
EXPOSITION SUR LES 4 COTÉS

3 ESTANTES ACERO -CARNE  
3 STEEL SHELVES  
3 ÉTAGÈRES RÉGLABLES

ILUMINACIÓN ESPECIFICA CARNE  
MEAT SPECIFIC LIGHTING  
ÉCLAIRAGE SPÉCIFIQUE À LA VIANDE

 -2°C / +4°C  
H: 60-90%

**VITRINAS VERTICALES - CARNE**

	TIPO	RANGO	HUMEDAD	REFRIGERANTE	DIMENSIONES	PESO	ESTANTES	PUERTA	TIPO ESTANTES	POTENCIA	VOLTAJE	RUEDAS	VOLUMEN	TERMOSTATO	LED
<b>AVV6P</b>	POSITIVO	-2°C / +4°C	60 - 90%	R290a	620x660x1960	195KG	3	CRISTAL	REGULABLES	650 W	230V-50HZ	SI	420 LT	DIGITAL	SI
<b>AVV12P</b>	POSITIVO	-2°C / +4°C	60 - 90%	R290a	1250x660x1960	390KG	3	CRISTAL	REGULABLES	1.300 W	230V-50HZ	SI	900 LT	DIGITAL	SI

PARA OTROS MEDIDAS Y ACABADOS, CONSULTAR DISPONIBILIDAD. - CHECK AVAILABILITY FOR OTHER MEASURES AND FINISHINGS - POUR AUTRES DIMENSIONS OU FINITIONS, CONSULTER LA DISPONIBILITÉ.

VITRINAS VERTICALES



NUEVOS DISEÑOS  
NEW DESIGN  
NOUVEAUX DESIGNS



MODELOS CON CERRADURA DE SERIE  
MODELS WITH LOCK INCLUDED  
MODÈLES AVEC SERRURE DE SÉRIE



PUERTA REVERSIBLE  
REVERSIBLE DOOR  
PORTE REVERSIBLE

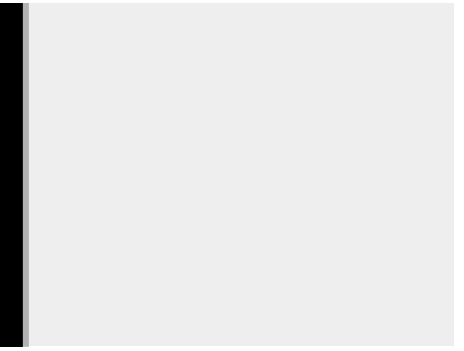

ILUMINACIÓN LED  
LED LIGHTING  
ILLUMINATION LEDS



MANGO ERGONOMICO  
ERGONOMIC HANDLE  
POIGNÉE ERGONOMIQUE



INTERIORES REGULABLES  
ADJUSTABLE INTERIOR  
INTÉRIEURS RÉGLABLES

ARMARIOS





**AOMOP**  
+1°C / +8°C



**AOMCN**  
-10°C / -14°C



**A1MON**  
-18°C / -22°C



**A2BCP-E**  
+1°C / +8°C



**A4BCP-E**  
+1°C / +8°C



**A4BCP-C**  
+1°C / +8°C



**A24MC-C**  
+1°C / +8°C  
PUERTA CORREDERA DOBLE

**ARMARIOS GAMMA "MINI"**

TIPO	RANGO	CAPACIDAD	DIMENSIONES	PESO	ESTANTES	PUERTA	TIPO ESTANTES	POTENCIA	VOLTAJE	RUEDAS	CERRADURA	TERMOSTATO	ACABADO	
<b>AOMCP</b>	POSITIVO	+1°C / +8°C	49LT	450x470x740	37KG	2	CRISTAL	REGULABLES	85W	230V-50HZ	NO	SI	DIGITAL	BIANCO
<b>AOMCN</b>	NEGATIVO	-18°C / -22°C	50LT	450x470x740	42KG	3	CRISTAL	REGULABLES	110W	230V-50HZ	NO	SI	DIGITAL	INOX
<b>A1MOP</b>	POSITIVO	+1°C / +8°C	122LT	600x600x835	51KG	2	OPACA	REGULABLES	123W	230V-50HZ	NO	SI	DIGITAL	INOX
<b>A1MON</b>	NEGATIVO	-18°C / -22°C	114LT	600x600x835	45KG	2	OPACA	REGULABLES	102W	230V-50HZ	NO	SI	DIGITAL	INOX

**ARMARIOS GAMMA "ECO"**

TIPO	RANGO	CAPACIDAD	DIMENSIONES	PESO	ESTANTES	PUERTA	TIPO ESTANTES	POTENCIA	VOLTAJE	RUEDAS	CERRADURA	TERMOSTATO	ACABADO	
<b>A2BCP-E</b>	POSITIVO	+1°C / +8°C	115LT	440x460x1605	50KG	4	CRISTAL	REGULABLES	185W	230V-50HZ	SI	MECANICO	BIANCO	
<b>A4BCP-E</b>	POSITIVO	+1°C / +8°C	317LT	590x600x1820	76KG	4 (495x428)	CRISTAL	REGULABLES	190W	230V-50HZ	SI	MECANICO	BIANCO	
<b>A4BCP-C</b>	POSITIVO	+1°C / +8°C	360LT	580x610x1980	75KG	4 (495x435)	CRISTAL	REGULABLES	280W	230V-50HZ	SI	SI	MECANICO	BIANCO
<b>A24MC-C</b>	POSITIVO	+1°C / +8°C	800LT	1180x700x2023	160KG	4 (495x435)	CRISTAL	REGULABLES	750W	230V-50HZ	SI	SI	DIGITAL	BIANCO



**A4BOP**  
+1°C / +8°C



**A4BON**  
-18°C / -22°C



**A4BCN**  
-18°C / -22°C



**A4NCP**  
+1°C / +8°C  
**\*consultar color**



**A4MCP**  
+1°C / +8°C



**A4MOP**  
+1°C / +8°C



**A4MCN**  
-18°C / -22°C



**A4MON**  
-18°C / -22°C

NEW  
DESIGNS

+ CAPACIDAD

PROFESIONAL

ARMARIOS

**ARMARIOS GAMMA "CLASSIC WHITE"**

TIPO	RANGO	CAPACIDAD	DIMENSIONES	PESO	ESTANTES	PUERTA	TIPO ESTANTES	POTENCIA	VOLTAJE	RUEDAS	CERRADURA	TERMOSTATO	ACABADO	
<b>A4BOP</b>	POSITIVO	+1°C / +8°C	317LT	590x643x1860	71KG	4 (495x428)	OPACA	REGULABLES	210W	230V-50HZ	SI	SI	DIGITAL	BLANCO
<b>A4BON</b>	NEGATIVO	-18°C / -22°C	316LT	620x665x1860	72KG	6 (495x380)	OPACA	ESTÁTICOS	400W	230V-50HZ	SI	SI	DIGITAL	BLANCO
<b>A4BCN</b>	NEGATIVO	-18°C / -22°C	316LT	620x665x1860	92KG	6 (495x380)	CRISTAL	ESTÁTICOS	400W	230V-50HZ	SI	SI	DIGITAL	BLANCO
<b>A4NCP</b>	POSITIVO	+1°C / +8°C	317LT	590x643x1860	90KG	4 (495x428)	CRISTAL	REGULABLES	210W	230V-50HZ	SI	SI	DIGITAL	NEGRO

**ARMARIOS GAMMA "CLASSIC INOX"**

TIPO	RANGO	CAPACIDAD	DIMENSIONES	PESO	ESTANTES	PUERTA	TIPO ESTANTES	POTENCIA	VOLTAJE	RUEDAS	CERRADURA	TERMOSTATO	ACABADO	
<b>A4MCP</b>	POSITIVO	+1°C / +8°C	317LT	590x643x1860	81KG	4 (495x428)	CRISTAL	REGULABLES	260W	230V-50HZ	SI	SI	DIGITAL	INOX
<b>A4MOP</b>	POSITIVO	+1°C / +8°C	317LT	590x643x1860	71KG	4 (495x428)	OPACA	REGULABLES	250W	230V-50HZ	SI	SI	DIGITAL	INOX
<b>A4MCN</b>	NEGATIVO	-18°C / -22°C	316LT	620x665x1860	92KG	6 (493x380)	CRISTAL	ESTÁTICOS	320W	230V-50HZ	SI	SI	DIGITAL	INOX
<b>A4MON</b>	NEGATIVO	-18°C / -22°C	330LT	620x665x1860	68KG	6 (493x380)	OPACA	ESTÁTICOS	300W	230V-50HZ	SI	SI	DIGITAL	INOX

ARMARIOS

NEW  
DESIGNS

+ CAPACIDAD



**A3MCP**  
+1°C / +8°C



**A3MOP**  
+1°C / +8°C



**A3MON**  
-18°C / -22°C



**A6MCP**  
+1°C / +8°C



**A6MOP**  
+1°C / +8°C



**A6MON**  
-18°C / -22°C

Capacidad para 14 cestas (50x19x17).  
NO INCLUIDAS

PROFESIONAL  
**ARMARIOS**

**ARMARIOS GAMMA "INNOVA INOX"**

TIPO	RANGO	CAPACIDAD	DIMENSIONES	PESO	ESTANTES	PUERTA	TIPO ESTANTES	POTENCIA	VOLTAJE	RUEDAS	CERRADURA	TERMOSTATO	ACABADO	
<b>A3MCP</b>	POSITIVO	+1°C / +8°C	406LT	600x700x1975	105KG	4	CRISTAL	REGULABLES	226W	230V-50HZ	NO	SI	DIGITAL	INOX
<b>A3MOP</b>	POSITIVO	+1°C / +8°C	406LT	600x700x1975	93KG	4	OPACA	REGULABLES	210W	230V-50HZ	NO	SI	DIGITAL	INOX
<b>A3MON</b>	NEGATIVO	-18°C / -22°C	406LT	600x700x1975	93KG	4	OPACA	REGULABLES	430W	230V-50HZ	NO	SI	DIGITAL	INOX

**ARMARIOS GAMMA "PLUS INOX"**

TIPO	RANGO	CAPACIDAD	DIMENSIONES	PESO	ESTANTES	PUERTA	TIPO ESTANTES	POTENCIA	VOLTAJE	RUEDAS	CERRADURA	TERMOSTATO	ACABADO
<b>A6MCP</b>	POSITIVO	+1°C / +8°C	511LT	750x720x1995	115KG	4	CRISTAL	REGULABLES	225W	230V-50HZ	NO	DIGITAL	INOX
<b>A6MOP</b>	POSITIVO	+1°C / +8°C	511LT	750x720x1995	100KG	4	OPACA	REGULABLES	220W	230V-50HZ	NO	DIGITAL	INOX
<b>A6MON</b>	NEGATIVO	-18°C / -22°C	511LT	750x720x1995	96KG	6	OPACA	ESTATICOS	330W	230V-50HZ	NO	DIGITAL	INOX
<b>A6MCN</b>	NEGATIVO	-18°C / -22°C	511LT	750x720x1995	96KG	6	CRISTAL	ESTATICOS	345W	230V-50HZ	NO	DIGITAL	INOX

ARMARIOS



**A24MO**  
+1°C / +8°C



**A24MC**  
+1°C / +8°C

960/1152 UD  
590/715 UD



**A24MON**  
-20°C / -15°C



pharmacy



**A0FCP**  
+1°C / +8°C



**A1FCP**  
+1°C / +8°C



**A3FCP**  
+1°C / +8°C



**A4FCP**  
+1°C / +8°C

**ARMARIOS GAMMA "FARMA"**

	TIPO	RANGO	CAPACIDAD	DIMENSIONES	PESO	ESTANTES	PUERTA	TIPO ESTANTES	POTENCIA	VOLTAJE	RUEDAS	CERRADURA	TERMOSTATO	ACABADO
<b>A0FOP</b>	POSITIVO	+1°C / +8°C	30LT	450x470+40x540	30KG	2	OPACO	REGULABLES	85W	230V-50HZ	NO	SI	DIGITAL	BLANCO
<b>A0FCP</b>	POSITIVO	+1°C / +8°C	52LT	450x470+40x740	36KG	3	CRISTAL	REGULABLES	85W	230V-50HZ	NO	SI	DIGITAL	BLANCO
<b>A1FCP</b>	POSITIVO	+1°C / +8°C	122LT	600x640+50x835	54KG	3	CRISTAL	REGULABLES	123W	230V-50HZ	NO	SI	DIGITAL	BLANCO
<b>A3FCP</b>	POSITIVO	+1°C / +8°C	324LT	600x700+50x1500	88KG	5	CRISTAL	REGULABLES	190W	230V-50HZ	SI	SI	DIGITAL	BLANCO
<b>A4FCP</b>	POSITIVO	+1°C / +8°C	386LT	600x645+45x1860	98KG	5	CRISTAL	REGULABLES	220W	230V-50HZ	SI	SI	DIGITAL	BLANCO

**ARMARIOS GAMMA "MAXI" INOX - FRIJO POSITIVO**

	TIPO	RANGO	CAPACIDAD	DIMENSIONES	PESO	ESTANTES	PUERTA	TIPO ESTANTES	POTENCIA	VOLTAJE	RUEDAS	CERRADURA	TERMOSTATO	ACABADO
<b>A24MO</b>	POSITIVO	+1°C / +8°C	765LT	1180x645x1980	170KG	4	CRISTAL	REGULABLES	460W	230V-50HZ	OP.	SI	DIGITAL	INOX
<b>A24MC</b>	POSITIVO	+1°C / +8°C	765LT	1180x645x1980	151KG	4	OPACA	REGULABLES	450W	230V-50HZ	OP.	SI	DIGITAL	INOX
<b>A24MON</b>	NEGATIVO	-20°C / -15°C	964LT	1250x690x2075	170KG	6	OPACA	REGULABLES	850W	230V-50HZ	OP.	NO	DIGITAL	INOX

PROFESIONAL

ARMARIOS

ARMARIOS



ARMARIOS VINO



PUERTA CON PROTECTOR ANTI-UV  
DOOR WITH UV PROTECTION  
PORTE AVEC PROTECTION ANTI UV



ILUMINACIÓN LED  
LED LIGHTING  
ILLUMINATION LEDS



ESTANTES CON GUIAS  
SLIDING SHELVES  
ÉTAGÈRES A GLISSIÈRES



ACCESORIO PARA INCLINAR BOTELLAS  
ACCESSORY TO TILT BOTTLES  
ACCESSOIRE POUR INCLINAISON BOUTEILLES



FILTRO DE CARBÓN ACTIVO  
ACTIVE CHARCOAL FILTER  
FILTRÉ A CHARBON ACTIF



SISTEMA ANTIVIBRACIÓN  
ANTI VIBRATION FILTER  
SYSTÈME ANTI-VIBRATION



**A0NCP**  
+3°C / +18°C

15 UD



**A1NCP**  
+3°C / +18°C

42 UD



+3°C / +18°C

127 UD



ARMARIOS GAMMA "WINE"

TIPO	RANGO	CAPACIDAD	DIMENSIONES	PESO	ESTANTES	TEMPERATURAS	TIPO ESTANTES	POTENCIA	VOLTAJE	RUEDAS	CERRADURA	TERMOSTATO	ACABADO	
<b>A0NCP</b>	POSITIVO	+5°C / +20°C	49LT	450x470x740	35KG	1+1	1	REGULABLES	112W	230V-50HZ	NO	SI	DIGITAL	NEGRO
<b>A1NCP</b>	POSITIVO	+5°C / +20°C	122LT	600x640x835	54KG	2	1	REGULABLES	123W	230V-50HZ	NO	SI	DIGITAL	NEGRO
<b>A3NCP</b>	POSITIVO	+5°C / +20°C	187+171LT	600x700x1500	91KG	4	1	REGULABLES	236W	230V-50HZ	SI	SI	DIGITAL	NEGRO

**DOBLE TEMPERATURA**



**A3NCP-2**  
+3°C / +18°C

127 UD



**A4NCP-E**

130 UD



**A4NCP**  
+3°C / +18°C

177 UD



**DOBLE TEMPERATURA**

ARMARIOS GAMMA "WINE"

TIPO	RANGO	CAPACIDAD	DIMENSIONES	PESO	ESTANTES	TEMPERATURAS	TIPO ESTANTES	POTENCIA	VOLTAJE	RUEDAS	CERRADURA	TERMOSTATO	ACABADO	
<b>A3NCP-2</b>	POSITIVO	+5°C / +20°C	187+171LT	600x700x1500	91KG	7+1	2	REGULABLES	250W	230V-50HZ	SI	SI	DIGITAL	NEGRO
<b>A4NCP-E</b>	POSITIVO	+5°C / +20°C	130LT	590x645x1860	81KG	5	1 ZONA	REGULABLES	260W	230V-50HZ	SI	SI	DIGITAL	NEGRO
<b>A4NCP</b>	POSITIVO	+5°C / +20°C	236+229LT	600x740x1865	115KG	10+1	2 ZONAS	REGULABLES	250W	230V-50HZ	SI	SI	DIGITAL	NEGRO



**VITRINAS VERTICALES - POSITIVOS**

TIPO	RANGO	REFRIGERANTE	DIMENSIONES	PESO	ESTANTES	PUERTA	TIPO ESTANTES	POTENCIA	VOLTAJE	RUEDAS	VOLUMEN	TERMOSTATO	LED
<b>AVV4P</b>	POSITIVO	+2°C / +8°C	R134a	515X485X1842	60KG	4	CRISTAL REGULABLES	240 W	230V-50HZ	SI	280 LT	DIGITAL	SI

PARA OTROS MEDIDAS Y ACABADOS , CONSULTAR DISPONIBILIDAD. - CHECK AVAIALBILITY FOR OTHER MEASURES AND FINISHINGS - POUR AUTRES DIMENSIONS OU FINITIONS, CONSULTER LA DISPONIBILITÉ.

**VITRINAS VERTICALES - CALIENTES**

TIPO	RANGO	CAPACIDAD	DIMENSIONES	PESO	ESTANTES	LATERALES	TIPO ESTANTES	POTENCIA	VOLTAJE	RUEDAS	TERMOSTATO	LED
<b>AVV9C</b>	CALIENTE	+30°C / +60°C	820LT	960x660x2040	160KG	4	CRISTAL REGULABLES	4.700 W	230V-50HZ	SI	DIGITAL	SI

PARA OTROS MEDIDAS Y ACABADOS , CONSULTAR DISPONIBILIDAD. - CHECK AVAIALBILITY FOR OTHER MEASURES AND FINISHINGS - POUR AUTRES DIMENSIONS OU FINITIONS, CONSULTER LA DISPONIBILITÉ.

PROFESIONAL

VITRINAS HORIZONTALES



SISTEMA DE REFRIGERACIÓN ESTÁTICA  
**STATIC REFRIGERATION SYSTEM**  
 SYSTÈME DE RÉFRIGÉRATION STATIQUE



FRONTAL BASE COMBINABLE CON PANELES DE ACABADOS PERSONALIZADOS  
**FRONT BASE SHEETS AND FRONT PANEL WITH COLOR-COATED SHEET**  
 FEUILLES DE BASE AVANT ET PANNEAU AVANT AVEC FEUILLES DE BASE SHFRONT REVÊTUES EN COULEUR ET PANNEAU AVANT AVEC FEUILLE REVÊTUE EN COULEUR

OPCIÓN CORTINAS NOCTURNAS PLEXIGLAS  
 PLEXIGLAS NIGHT CURTAINS OPTIONÉVAPORAION  
 OPTION RIDEAUX DE NUIT PLEXIGLAS



CRISTAL FRONTAL RECTO MONOLÍTICO  
**MONOLITHIC STRAIGHT FRONT GLASS**  
 VITRE FRONTALE DROIT MONOLITHIQUE

CÁMARA FRIGORÍFICA INTERIOR  
**INTERNAL REFRIGERATOR CAMERA**  
 CAMÉRA RÉFRIGÉRATEUR INTERNE

EVAPORACIÓN AUTOMÁTICA DEL CONDENSADO  
**AUTOMATIC EVAPORATION**  
 ÉVAPORAION AUTOMATIQUE DU CONDENSEUR

**VITRINAS HORIZONTALES - MULTIUSOS**

TIPO	RANGO	CAPACIDAD	DIMENSIONES	FRIGORÍFICA	ESTANTES	ESTANTES	SUPERFICIE EXPO	PUERTAS CORREDERAS	POTENCIA	VOLTAJE	TERMOSTATO	LED
<b>VSE100P</b>	POSITIVO +1°C/+10°C	160 LT	1060x860x1230	412W	1 (0.5M2)				286 W	230V-50HZ	DIGITAL	SI
<b>VSE130P</b>	POSITIVO +1°C/+10°C	210 LT	1300x860x1230	412W	1 (0.6M2)				286 W	230V-50HZ	DIGITAL	SI
<b>VSE150P</b>	POSITIVO +1°C/+10°C	240 LT	1500x860x1230	412W	1 (0.7M2)				290W	230V-50HZ	DIGITAL	SI
<b>VSE170P</b>	POSITIVO +1°C/+10°C	270 LT	1700x860x1230	549W	1 (0.8M2)				365 W	230V-50HZ	DIGITAL	SI
<b>VSE200P</b>	POSITIVO +1°C/+10°C	330 LT	2040x860x1230	549W	1 (1M2)				365 W	230V-50HZ	DIGITAL	SI

\*PARA OTROS MEDIDAS Y ACABADOS , CONSULTAR DISPONIBILIDAD. - CHECK AVAILABILITY FOR OTHER MEASURES AND FINISHINGS - POUR AUTRES DIMENSIONS OU FINITIONS, CONSULTER LA DISPONIBILITÉ.

\*\* MODELOS SELF SERVICES, CRISTAL BAJO , ABIERTOS SIN PUERTAS - SELF SERVICES MODELS, LOW GLASS, OPEN WITHOUT DOORS - MODÈLES AUTO-SERVICES, VERRE BAS, OUVERT SANS PORTES -



ILUMINACIÓN INTERIOR EN CADA ESTANTE  
**INTERIOR LIGHTING IN EVERY SHELF**  
 ILLUMINATION INTÉRIEURE A CHAQUE ÉTAGE

ESTANTE REGULABLES  
**ADJUSTABLE SHELF**  
 ÉTAGÈRES RÉGLABLES

CONTROL ELECTRÓNICO DE TEMPERATURA  
**AUTOMATIC TEMPERATURE CONTROL**  
 CONTRÔLE ÉLECTRONIQUE DE TEMPÉRATURE

DESCONGELACIÓN AUTOMÁTICA  
**AUTOMATIC DEFROSTING**  
 DÉCONGÉLATION AUTOMATIQUE

LATERALES DE ACERO REVESTIDOS EN NEGRO  
**BLACK COATED STEEL LATERAL**  
 LATÉRAUX EN ACIER RECOUVERTS EN NOIR



PUERTAS TRASERAS CORREDERAS CON DOBLE CRISTAL  
**SLIDING BACK DOOR WITH DOUBLE GLASS**  
 PORTES ARRIÈRE COULISSANTES DOUBLE VITRAGE

CRISTAL FRONTAL RECTO MONOLÍTICO  
**MONOLITHIC STRAIGHT FRONT GLASS**  
 VITRE FRONTALE DROITE MONOLITHIQUE

SISTEMA DE REFRIGERACIÓN VENTILADA  
**VENTILATED REFRIGERATION SYSTEM**  
 SYSTÈME DE RÉFRIGÉRATION VENTILÉE

EVAPORACIÓN AUTOMÁTICA DEL CONDENSADO  
**AUTOMATIC EVAPORATION**  
 ÉVAPORAION AUTOMATIQUE DU CONDENSEUR

ILUMINACIÓN INTERIOR EN CADA ESTANTE  
**INTERIOR LIGHTING IN EVERY SHELF**  
 ILLUMINATION INTÉRIEURE A CHAQUE ÉTAGE

ESTANTE REGULABLES  
**ADJUSTABLE SHELF**  
 ÉTAGÈRES RÉGLABLES

CONTROL ELECTRÓNICO DE TEMPERATURA  
**AUTOMATIC TEMPERATURE CONTROL**  
 CONTRÔLE ÉLECTRONIQUE DE TEMPÉRATURE

DESCONGELACIÓN AUTOMÁTICA  
**AUTOMATIC DEFROSTING**  
 DÉCONGÉLATION AUTOMATIQUE

LATERALES DE MADERA EN COLOR A ESCOGER  
**WOOD SIDES IN COLOR TO CHOOSE**  
 CÔTÉS EN BOIS DE COULEUR À CHOISIR

EVAPORACIÓN AUTOMÁTICA DEL CONDENSADO  
**AUTOMATIC EVAPORATION**  
 ÉVAPORAION AUTOMATIQUE DU CONDENSEUR

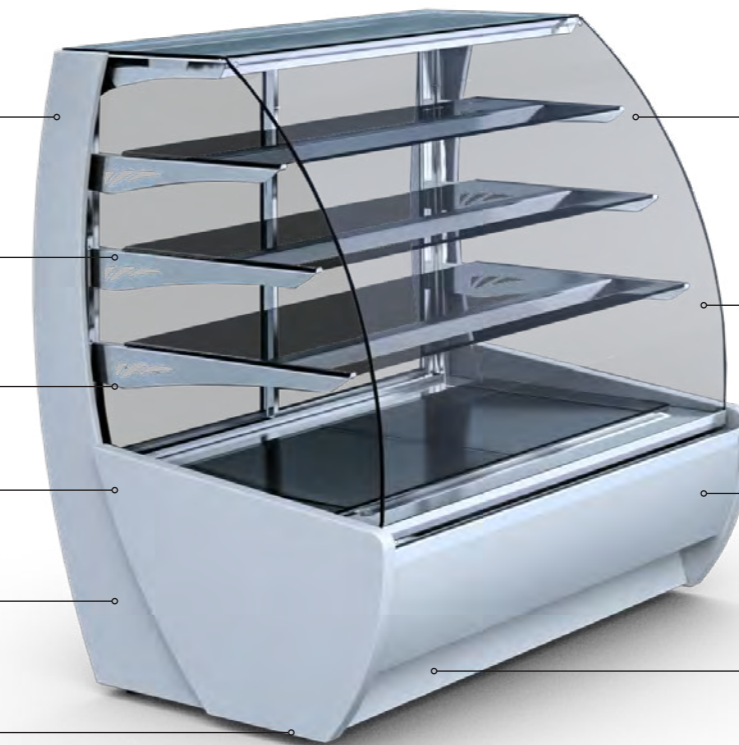

CRISTAL FRONTAL CURVO MONOLÍTICO  
**MONOLITHIC CURVED FRONT GLASS**  
 VITRE FRONTALE COURBÉE MONOLITHIQUE

PUERTAS TRASERAS CORREDERAS CON DOBLE CRISTAL  
**SLIDING BACK DOOR WITH DOUBLE GLASS**  
 PORTES ARRIÈRE COULISSANTES DOUBLE VITRAGE

CONSULTAR PARA OTROS MODELOS Y COLORES  
**OTHER MODELS AND COLOURS TO BE CONSULTED**  
 CONSULTER POUR AUTRES MODÈLES OU COLORIS

SISTEMA DE REFRIGERACIÓN VENTILADA  
**VENTILATED REFRIGERATION SYSTEM**  
 SYSTÈME DE RÉFRIGÉRATION VENTILÉE

**VITRINAS HORIZONTALES -RECTAS MONOLÍTICO**

	TIPO	RANGO	CAPACIDAD	DIMENSIONES	PESO	ESTANTES	TIPO ESTANTES	POTENCIA	VOLTAJE	TERMOSTATO	LED
<b>VSE70R</b>	POSITIVO	+5°C/+15°C	320 LT	610x835x1280	90KG	2 (0.8M2)	REGULABLES	309 W	230V-50HZ	DIGITAL	SI
<b>VSE100R</b>	POSITIVO	+5°C/+15°C	480 LT	910x835x1280	140KG	2 (1.3M2)	REGULABLES	542 W	230V-50HZ	DIGITAL	SI
<b>VSE140R</b>	POSITIVO	+5°C/+15°C	690 LT	1310x835x1280	180KG	2 (1.9M2)	REGULABLES	715 W	230V-50HZ	DIGITAL	SI
<b>VSE70RN</b>	NEUTRO	NEUTRO	320 LT	610x835x1280	90KG	2 (0.8M2)	REGULABLES	25 W	230V-50HZ	-	SI
<b>VSE100RN</b>	NEUTRO	NEUTRO	480 LT	910x835x1280	140KG	2 (1.3M2)	REGULABLES	25W	230V-50HZ	-	SI
<b>VSE140RN</b>	NEUTRO	NEUTRO	690 LT	1310x835x1280	180KG	2 (1.9M2)	REGULABLES	25 W	230V-50HZ	-	SI

PARA OTROS MEDIDAS Y ACABADOS , CONSULTAR DISPONIBILIDAD. - CHECK AVAILABILITY FOR OTHER MEASURES AND FINISHINGS - POUR AUTRES DIMENSIONS OU FINITIONS, CONSULTER LA DISPONIBILITÉ.

**VITRINAS HORIZONTALES -CURVADA MONOLÍTICO**

	TIPO	RANGO	CAPACIDAD	DIMENSIONES	PESO	ESTANTES	TIPO ESTANTES	POTENCIA	VOLTAJE	TERMOSTATO	LED
<b>VSE70C</b>	POSITIVO	+5°C/+15°C	334 LT	705x970x1370	120KG	3 (1.2M2)	REGULABLES	309 W	230V-50HZ	DIGITAL	SI
<b>VSE100C</b>	POSITIVO	+5°C/+15°C	496 LT	1005x970x1370	170KG	3 (1.8M2)	REGULABLES	542 W	230V-50HZ	DIGITAL	SI
<b>VSE140C</b>	POSITIVO	+5°C/+15°C	715 LT	1405x970x1370	220KG	3 (2.6M2)	REGULABLES	715 W	230V-50HZ	DIGITAL	SI
<b>VSE70CN</b>	NEUTRO	NEUTRO	334 LT	705x970x1370	110KG	3 (1.2M2)	REGULABLES	25 W	230V-50HZ	-	SI
<b>VSE100CN</b>	NEUTRO	NEUTRO	496 LT	1005x970x1370	160KG	3 (1.8M2)	REGULABLES	25 W	230V-50HZ	-	SI
<b>VSE140CN</b>	NEUTRO	NEUTRO	715 LT	1405x970x1370	210KG	3 (2.6M2)	REGULABLES	25 W	230V-50HZ	-	SI

PARA OTROS MEDIDAS Y ACABADOS , CONSULTAR DISPONIBILIDAD. - CHECK AVAILABILITY FOR OTHER MEASURES AND FINISHINGS - POUR AUTRES DIMENSIONS OU FINITIONS, CONSULTER LA DISPONIBILITÉ.

ILUMINACIÓN INTERIOR EN CADA ESTANTE  
 INTERIOR LIGHTING IN EVERY SHELF  
 ILLUMINATION INTÉRIEURE A CHAQUE ÉTAGE

ESTANTE REGULABLES  
 ADJUSTABLE SHELF  
 ÉTAGÈRES RÉGLABLES

DESCONGELACIÓN AUTOMÁTICA  
 AUTOMATIC DEFROSTING  
 DÉCONGÉLATION AUTOMATIQUE

LATERALES DE ACERO REVESTIDOS EN BLANCO  
 WHITE COATED STEEL LATERAL  
 LATÉRAUX EN ACIER RECOUVERTS EN BLANC

CRISTAL ABATIBLE  
 FOLDING GLASS  
 PLIANTE VERRE

PUERTAS TRASERAS CORREDERAS CON DOBLE CRISTAL  
 SLIDING BACK DOOR WITH DOUBLE GLASS  
 PORTES ARRIÈRE COULISSANTES DOUBLE VITRAGE

CRISTAL FRONTAL RECTO MONOLÍTICO  
 MONOLITHIC STRAIGHT FRONT GLASS  
 VITRE FRONTALE TOUT DROIT MONOLITHIQUE

SISTEMA DE REFRIGERACIÓN VENTILADA  
 VENTILATED REFRIGERATION SYSTEM  
 SYSTÈME DE RÉFRIGÉRATION VENTILÉE

EVAPORACIÓN AUTOMÁTICA DEL CONDENSADO  
 AUTOMATIC EVAPORATION  
 ÉVAPORAION AUTOMATIQUE DU CONDENSEUR

CONTROL ELECTRÓNICO DE TEMPERATURA  
 AUTOMATIC TEMPERATURE CONTROL  
 CONTRÔLE ÉLECTRONIQUE DE TEMPÉRATURE

**VITRINAS HORIZONTALES -RECTA RADIO CURVO 2P**

	TIPO	RANGO	CAPACIDAD	DIMENSIONES	PESO	ESTANTES	TIPO ESTANTES	POTENCIA	VOLTAJE	TERMOSTATO	LED
<b>VSE70R2</b>	POSITIVO	+5°C/+15°C	288 LT	610x835x1200	20KG	2 (0,75M2)	REGULABLES	309 W	230V-50HZ	DIGITAL	SI
<b>VSE100R2</b>	POSITIVO	+5°C/+15°C	440 LT	910x835x1200	130KG	2 (1,16M2)	REGULABLES	542 W	230V-50HZ	DIGITAL	SI
<b>VSE140R2</b>	POSITIVO	+5°C/+15°C	640 LT	1310x835x1200	170KG	2 (1,70M2)	REGULABLES	715 W	230V-50HZ	DIGITAL	SI
<b>VSE70RN2</b>	NEUTRO	NEUTRO	288 LT	610x835x1200	80KG	2 (0,75M2)	REGULABLES	25 W	230V-50HZ	-	SI
<b>VSE100RN2</b>	NEUTRO	NEUTRO	440 LT	910x835x1200	130KG	2 (1,16M2)	REGULABLES	25W	230V-50HZ	-	SI
<b>VSE140RN2</b>	NEUTRO	NEUTRO	640 LT	1310x835x1200	170KG	2 (1,70M2)	REGULABLES	25 W	230V-50HZ	-	SI

PARA OTROS MEDIDAS Y ACABADOS , CONSULTAR DISPONIBILIDAD. - CHECK AVAILABILITY FOR OTHER MEASURES AND FINISHINGS - POUR AUTRES DIMENSIONS OU FINITIONS, CONSULTER LA DISPONIBILITÉ.

ILUMINACIÓN INTERIOR EN CADA ESTANTE  
 INTERIOR LIGHTING IN EVERY SHELF  
 ILLUMINATION INTÉRIEURE A CHAQUE ÉTAGE

ESTANTE REGULABLES  
 ADJUSTABLE SHELF  
 ÉTAGÈRES RÉGLABLES

DESCONGELACIÓN AUTOMÁTICA  
 AUTOMATIC DEFROSTING  
 DÉCONGÉLATION AUTOMATIQUE

LATERALES DE ACERO REVESTIDOS EN BLANCO  
 WHITE COATED STEEL LATERAL  
 LATÉRAUX EN ACIER RECOUVERTS EN BLANC

CRISTAL ABATIBLE  
 FOLDING GLASS  
 PLIANTE VERRE

PUERTAS TRASERAS CORREDERAS CON DOBLE CRISTAL  
 SLIDING BACK DOOR WITH DOUBLE GLASS  
 PORTES ARRIÈRE COULISSANTES DOUBLE VITRAGE

CRISTAL FRONTAL RECTO MONOLÍTICO  
 MONOLITHIC STRAIGHT FRONT GLASS  
 VITRE FRONTALE TOUT DROIT MONOLITHIQUE

SISTEMA DE REFRIGERACIÓN VENTILADA  
 VENTILATED REFRIGERATION SYSTEM  
 SYSTÈME DE RÉFRIGÉRATION VENTILÉE

EVAPORACIÓN AUTOMÁTICA DEL CONDENSADO  
 AUTOMATIC EVAPORATION  
 ÉVAPORAION AUTOMATIQUE DU CONDENSEUR

CONTROL ELECTRÓNICO DE TEMPERATURA  
 AUTOMATIC TEMPERATURE CONTROL  
 CONTRÔLE ÉLECTRONIQUE DE TEMPÉRATURE

**VITRINAS HORIZONTALES -RECTA RADIO CURVO 3P**

	TIPO	RANGO	CAPACIDAD	DIMENSIONES	PESO	ESTANTES	TIPO ESTANTES	POTENCIA	VOLTAJE	TERMOSTATO	LED
<b>VSE70R3</b>	POSITIVO	+5°C/+15°C	360 LT	610x835x1380	90KG	3 (1,13M2)	REGULABLES	309 W	230V-50HZ	DIGITAL	SI
<b>VSE100R3</b>	POSITIVO	+5°C/+15°C	550 LT	910x835x1380	140KG	3 (1,74M2)	REGULABLES	542 W	230V-50HZ	DIGITAL	SI
<b>VSE140R3</b>	POSITIVO	+5°C/+15°C	800 LT	1310x835x1380	180KG	3 (2,55M2)	REGULABLES	715 W	230V-50HZ	DIGITAL	SI
<b>VSE70RN3</b>	NEUTRO	NEUTRO	360 LT	610x835x1380	90KG	3 (0,8M2)	REGULABLES	25 W	230V-50HZ	-	SI
<b>VSE100RN3</b>	NEUTRO	NEUTRO	550 LT	910x835x1380	140KG	3 (1,3M2)	REGULABLES	25W	230V-50HZ	-	SI
<b>VSE140RN3</b>	NEUTRO	NEUTRO	800 LT	1310x835x1280	180KG	3 (1,9M2)	REGULABLES	25 W	230V-50HZ	-	SI

PARA OTROS MEDIDAS Y ACABADOS , CONSULTAR DISPONIBILIDAD. - CHECK AVAILABILITY FOR OTHER MEASURES AND FINISHINGS - POUR AUTRES DIMENSIONS OU FINITIONS, CONSULTER LA DISPONIBILITÉ.

ILUMINACIÓN INTERIOR EN CADA ESTANTE  
*INTERIOR LIGHTING IN EVERY SHELF*  
 ILLUMINATION INTÉRIEURE A CHAQUE ÉTAGE

ESTANTE REGULABLES  
*ADJUSTABLE SHELF*  
 ÉTAGÈRES RÉGLABLES

CONTROL ELECTRÓNICO DE TEMPERATURA  
*AUTOMATIC TEMPERATURE CONTROL*  
 CONTRÔLE ÉLECTRONIQUE DE TEMPÉRATURE

DESCONGELACIÓN AUTOMÁTICA  
*AUTOMATIC DEFROSTING*  
 DÉCONGÉLATION AUTOMATIQUE

CONSULTAR PARA OTROS MODELOS Y COLORES  
*OTHER MODELS AND COLOURS TO BE CONSULTED*  
 CONSULTER POUR AUTRES MODÈLES OU COLORIS

EVAPORACIÓN AUTOMÁTICA DEL CONDENSADO  
*AUTOMATIC EVAPORATION*  
 ÉVAPORAION AUTOMATIQUE DU CONDENSEUR



INNOVADOR SISTEMA DE EXTRACCIÓN DEL CRISTAL  
 CON CIERRE ELECECTROMAGNETICO  
*INNOVATIVE SYSTEM OF WITHDRAWABLE FRONT  
 WITH ELECTROMAGNETIC LOCK*  
 SYSTEME D'EXTRACTION DE CRISTAUX INNOVANT  
 AVEC FERMETURE ELECECTROMAGNETIQUE

ILUMINACIÓN INTERIOR EN CADA ESTANTE  
*INTERIOR LIGHTING IN EVERY SHELF*  
 ILLUMINATION INTÉRIEURE A CHAQUE ÉTAGE

ESTANTE REGULABLES  
*ADJUSTABLE SHELF*  
 ÉTAGÈRES RÉGLABLES

CONTROL ELECTRÓNICO DE TEMPERATURA  
*AUTOMATIC TEMPERATURE CONTROL*  
 CONTRÔLE ÉLECTRONIQUE DE TEMPÉRATURE

DESCONGELACIÓN AUTOMÁTICA  
*AUTOMATIC DEFROSTING*  
 DÉCONGÉLATION AUTOMATIQUE

EVAPORACIÓN AUTOMÁTICA DEL CONDENSADO  
*AUTOMATIC EVAPORATION*  
 ÉVAPORAION AUTOMATIQUE DU CONDENSEUR

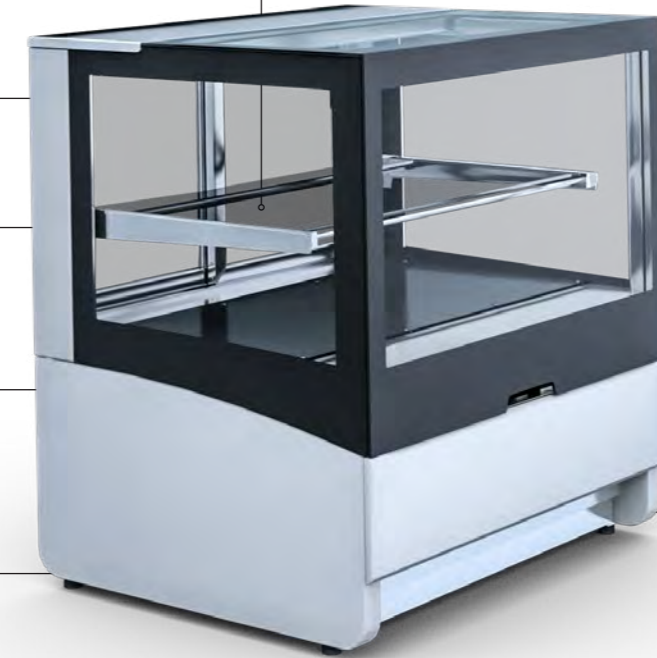

INNOVADOR SISTEMA DE EXTRACCIÓN DEL CRISTAL  
 CON CIERRE ELECECTROMAGNETICO  
*INNOVATIVE SYSTEM OF WITHDRAWABLE FRONT  
 WITH ELECTROMAGNETIC LOCK*  
 SYSTEME D'EXTRACTION DE CRISTAUX INNOVANT  
 AVEC FERMETURE ELECECTROMAGNETIQUE

CONSULTAR PARA OTROS MODELOS Y COLORES  
*OTHER MODELS AND COLOURS TO BE CONSULTED*  
 CONSULTER POUR AUTRES MODÈLES OU COLORIS

SISTEMA DE REFRIGERACIÓN VENTILADA  
*VENTILATED REFRIGERATION SYSTEM*  
 SYSTEME DE RÉFRIGÉRATION VENTILÉE

**VITRINAS HORIZONTALES -RECTA CRISTALES CÁMARA 3P**

	TIPO	RANGO	CAPACIDAD	DIMENSIONES	PESO	ESTANTES	TIPO ESTANTES	POTENCIA	VOLTAJE	TERMOSTATO	LED
<b>VSE70I</b>	POSITIVO	+2°C/+15°C	395 LT	700x835x1400	90KG	3 (1.2M2)	REGULABLES	295 W	230V-50HZ	DIGITAL	SI
<b>VSE100I</b>	POSITIVO	+2°C/+15°C	582 LT	1000x835x1400	140KG	3 (1.8M2)	REGULABLES	550 W	230V-50HZ	DIGITAL	SI
<b>VSE140I</b>	POSITIVO	+2°C/+15°C	825 LT	1400x835x1400	180KG	3 (2.5M2)	REGULABLES	797 W	230V-50HZ	DIGITAL	SI
<b>VSE70IN</b>	NEUTRO	NEUTRO	395 LT	700x835x1400	90KG	3 (1.2M2)	REGULABLES	25 W	230V-50HZ	-	SI
<b>VSE100IN</b>	NEUTRO	NEUTRO	582 LT	1000x835x1400	140KG	3 (1.8M2)	REGULABLES	25W	230V-50HZ	-	SI
<b>VSE140IN</b>	NEUTRO	NEUTRO	825 LT	1400x835x1400	180KG	3(2.5M2)	REGULABLES	25 W	230V-50HZ	-	SI

PARA OTROS MEDIDAS Y ACABADOS , CONSULTAR DISPONIBILIDAD. - CHECK AVAILABILITY FOR OTHER MEASURES AND FINISHINGS - POUR AUTRES DIMENSIONS OU FINITIONS, CONSULTER LA DISPONIBILITÉ.

**VITRINAS HORIZONTALES -RECTA CRISTALES CÁMARA 1P**

	TIPO	RANGO	CAPACIDAD	DIMENSIONES	ESTANTES	TIPO ESTANTES	POTENCIA	VOLTAJE	TERMOSTATO	LED
<b>VSE70IS</b>	POSITIVO	+2°C/+15°C	245 LT	700x835x1100	2 (0.6M2)	REGULABLES	290 W	230V-50HZ	DIGITAL	SI
<b>VSE100IS</b>	POSITIVO	+2°C/+15°C	362 LT	1000x835x1100	2 (1.0M2)	REGULABLES	545 W	230V-50HZ	DIGITAL	SI
<b>VSE140IS</b>	POSITIVO	+2°C/+15°C	513 LT	1400x835x1100	2 (1.2M2)	REGULABLES	791W	230V-50HZ	DIGITAL	SI
<b>VSE70ISN</b>	NEUTRO	NEUTRO	245 LT	700x835x1100	2 (0.6M2)	REGULABLES	25 W	230V-50HZ	-	SI
<b>VSE100ISN</b>	NEUTRO	NEUTRO	362 LT	1000x835x1100	2 (1.0M2)	REGULABLES	25W	230V-50HZ	-	SI
<b>VSE140ISN</b>	NEUTRO	NEUTRO	513 LT	1400x835x1100	2 (1.2M2)	REGULABLES	25 W	230V-50HZ	-	SI

PARA OTROS MEDIDAS Y ACABADOS , CONSULTAR DISPONIBILIDAD. - CHECK AVAILABILITY FOR OTHER MEASURES AND FINISHINGS - POUR AUTRES DIMENSIONS OU FINITIONS, CONSULTER LA DISPONIBILITÉ.



**BAJOMOSTRADORES SIN PETO**

TIPO	RANGO	CAPACIDAD	DIMENSIONES	PESO	PUERTA	POTENCIA	VOLTAJE	PETO	TERMOSTATO	PUERTAS	
<b>BJ15</b>	POSITIVO	+1°C / +8°C	235LT	1500x600x850	90KG	OPACA	180W	230V-50HZ	NO	DIGITAL	2
<b>BJ20</b>	POSITIVO	+1°C / +8°C	361LT	2000x600x850	110KG	OPACA	224W	230V-50HZ	NO	DIGITAL	3
<b>BJ25</b>	POSITIVO	+1°C / +8°C	488LT	2500x600x850	140KG	OPACA	344W	230V-50HZ	NO	DIGITAL	4

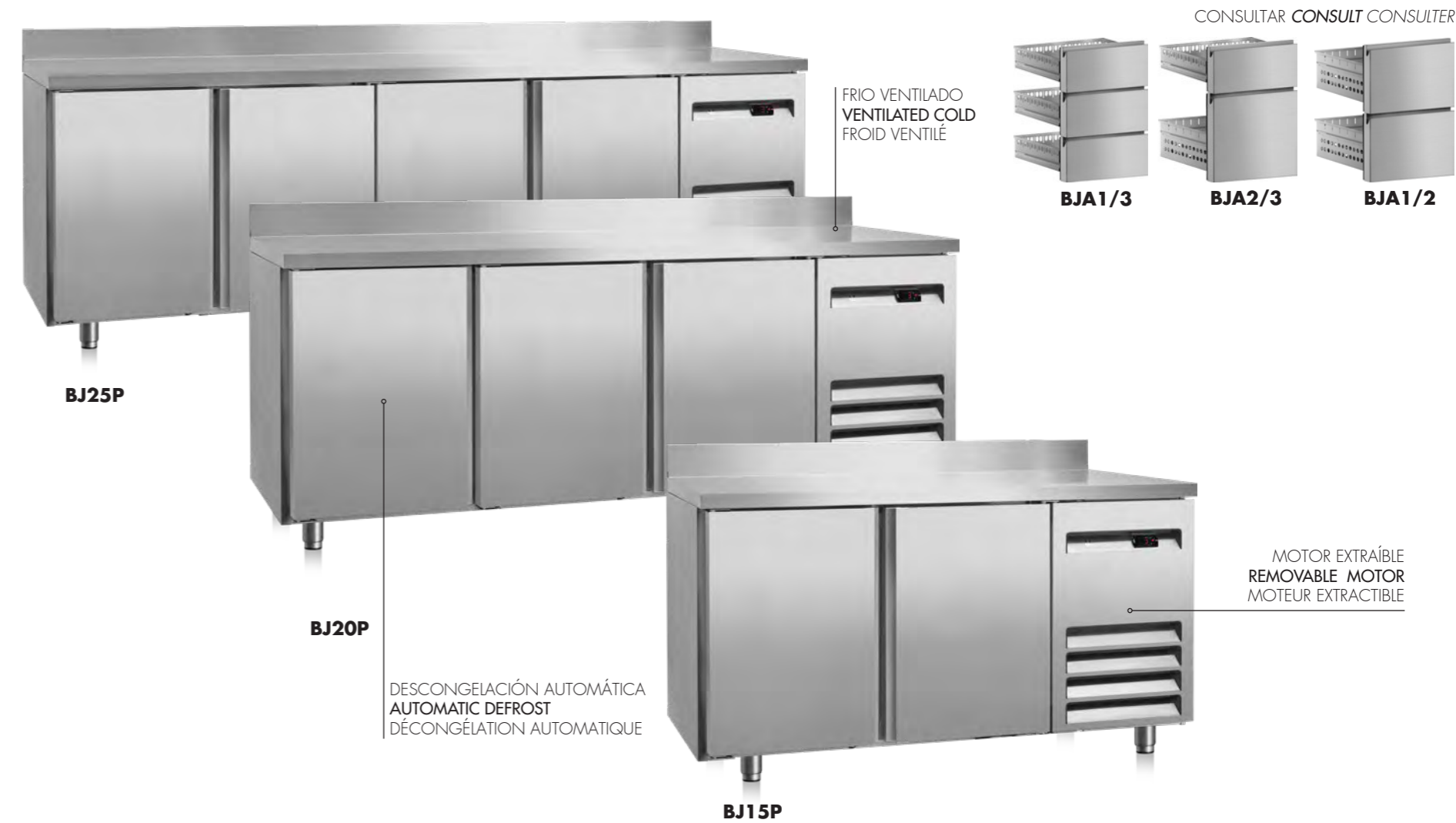

**BAJOMOSTRADORES CON PETO**

TIPO	RANGO	CAPACIDAD	DIMENSIONES	PESO	PUERTA	POTENCIA	VOLTAJE	PETO	TERMOSTATO	PUERTAS	
<b>BJ15P</b>	POSITIVO	+1°C / +8°C	234LT	1500x600x850	90KG	OPACA	180W	230V-50HZ	SI	DIGITAL	2
<b>BJ20P</b>	POSITIVO	+1°C / +8°C	361LT	2000x600x850	110KG	OPACA	224W	230V-50HZ	SI	DIGITAL	3
<b>BJ25P</b>	POSITIVO	+1°C / +8°C	488LT	2500x600x850	140KG	OPACA	244W	230V-50HZ	SI	DIGITAL	4



CAF100

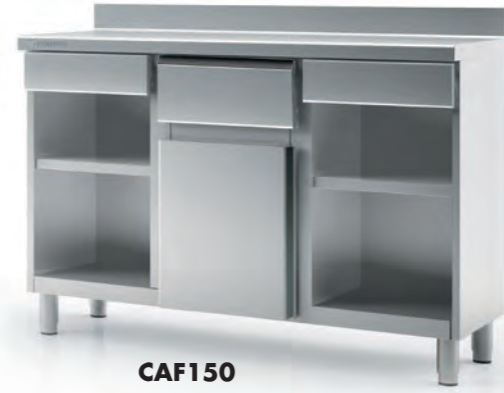

CAF150



CAF200



EST100



EST150



EST200



FRE200C



FRE200



FRE150C



FRE150

**MUEBLES CAFETEROS Y ESTANTERIAS**

TIPO	RANGO	PIES REGULABLES	DIMENSIONES	CAJONES	TOLVA CAFÉ	ACERO INOX	PETO
CAF100	NEUTRO	ACERO INOX	SI	990x600x1040	1	SI	SI
CAF150	NEUTRO	ACERO INOX	SI	1495x600x1040	1	SI	SI
CAF200	NEUTRO	ACERO INOX	SI	2020x600x1040	1	SI	SI
EST100	NEUTRO	ACERO INOX	SI	990x600x1040	NO	NO	SI
EST100	NEUTRO	ACERO INOX	SI	1495x600x1040	NO	NO	SI
EST100	NEUTRO	ACERO INOX	SI	2020x600x1040	NO	NO	SI

**FRENTEMOSTRADORES**

TIPO	RANGO	CAPACIDAD	DIMENSIONES	PUERTA	POTENCIA	VOLTAJE	PETO	LEDS	TERMOSTATO	FUERTAS	
FRE150	POSITIVO	-2°C / +8°C	325LT	1495x600x1040	OPACA	235W	230V-50HZ	SI	NO	DIGITAL	2
FRE200	POSITIVO	-2°C / +8°C	504LT	2020x600x1040	OPACA	238W	230V-50HZ	SI	NO	DIGITAL	3
FRE150C	POSITIVO	-2°C / +8°C	325LT	1495x600x1040	CRISTAL	247W	230V-50HZ	SI	SI	DIGITAL	2
FRE200C	POSITIVO	-2°C / +8°C	504LT	2020x600x1040	CRISTAL	255W	230V-50HZ	SI	SI	DIGITAL	3

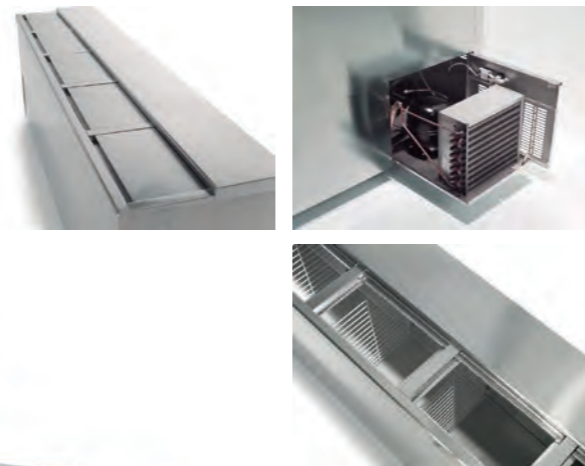

**BOTELLEROS**

	TIPO	RANGO	DIMENSIONES	CAPACIDAD	PUERTAS	PUERTA	SEPARADOR	POTENCIA	VOLTAJE	TERMOSTATO
<b>B010</b>	POSITIVO	+2°C / +8°C	1010x550x850	270 L	2	OPACA	1	175W	230V-50HZ	MECANICO
<b>B015</b>	POSITIVO	+2°C / +8°C	1500x550x850	420 L	3	OPACA	2	205W	230V-50HZ	MECANICO
<b>B020</b>	POSITIVO	+2°C / +8°C	1990x550x850	580 L	4	OPACA	3	304W	230V-50HZ	MECANICO
<b>B025</b>	POSITIVO	+2°C / +8°C	2480x550x850	720 L	5	OPACA	4	502W	230V-50HZ	MECANICO

PARA OTROS MEDIDAS Y ACABADOS , CONSULTAR DISPONIBILIDAD. - CHECK AVAILABILITY FOR OTHER MEASURES AND FINISHINGS - POUR AUTRES DIMENSIONS OU FINITIONS, CONSULTER LA DISPONIBILITÉ.



**FG3**

**FG2**

**FRIGOBARES**

	TIPO	RANGO	CAPACIDAD	DIMENSIONES	PESO	PUERTA	POTENCIA	VOLTAJE	BOTELLAS	LATAS	TERMOSTATO	PUERTAS
<b>FG2</b>	POSITIVO	+1°C / +8°C	312LT	1255x565x905	92KG	CRISTAL	370W	230V-50HZ	264	432	DIGITAL	2
<b>FG3</b>	POSITIVO	+1°C / +8°C	488LT	1775x565x905	108KG	CRISTAL	370W	230V-50HZ	440	744	DIGITAL	3

PARA OTROS MEDIDAS Y ACABADOS , CONSULTAR DISPONIBILIDAD. - CHECK AVAILABILITY FOR OTHER MEASURES AND FINISHINGS - POUR AUTRES DIMENSIONS OU FINITIONS, CONSULTER LA DISPONIBILITÉ.

MANTIENE INTACTAS LA FRESCURA DE LOS ALIMENTOS  
*IT KEEPS THE FRESHNESS OF THE PRODUCT INTACT*  
MAINTIEN INTACTE LA FRAICHEUR DES ALIMENTS.

FABRICADAS EN ACERO INOX  
*MANUFACTURED IN STAINLESS STEEL*  
FABRIQUÉES EN ACIER INOX

FIABILIDAD Y SENCILLEZ DE USO  
*RELIABILITY AND EASY TO USE*  
FIABILITÉ ET SIMPLICITÉ D'UTILISATION

EVITA PÉRDIDAS DE PESO DEL PRODUCTO  
*IT HELPS TO KEEP THE PRODUCT HYDRATED*  
ÉVITE DES PERTES DE POIDS DU PRODUIT



EL ABATIMIENTO RÁPIDO PERMITE PROTEGER LOS ALIMENTOS CONTRA LA AGRESIÓN BACTERIANA  
*BLAST CHILLING PROTECTS FOOD AGAINST BACTERIAL AGGRESSION*  
LE REFROIDISSEMENT RAPIDE PERMET DE PROTÉGER LES ALIMENTS CONTRE LES AGRESSIONS BACTÉRIENNES.

DOS METODOS DE CONFIGURACIÓN; POR TIEMPO O POR Sonda EN EL INTERIOR DEL PRODUCTO  
*TWO SETTING MODES: TIME MODE OR PROBE INSIDE THE PRODUCT MODE*  
DEUX MÉTHODES DE CONFIGURATION : PAR TEMPS OU PAR SONDÉ DANS LE COEUR DU PRODUIT

POSIBILIDAD DE PLANIFICAR CUALQUIER PRODUCCIÓN EVITANDO DESPERDICIOS  
*IT GIVES YOU THE POSSIBILITY TO PLAN ANY PRODUCTION AVOIDING WASTE*  
POSSIBILITÉ DE PLANIFIER N'IMPORTE QUELLE PRODUCTION EN ÉVITANT DES PERTES



**ABATIDORES DE TEMPERATURA**

	DIMENSIONES	CAPACIDAD BANDEJAS	SEPARACIÓN BANDEJAS	RENDIMIENTO 90°/3°C	RENDIMIENTO 90°/-18°C	POTENCIA ABSORBIDA	POTENCIA FRIGORIFICA	TERMOSTATO	VOLTAJE
<b>AB5</b>	800X700X900	5 GN1/1	67MM	18KG	11KG	1.185W	807W	DIGITAL	230V-50Hz
<b>AB10</b>	800X780X1700	10 GN1/1	67MM	34KG	22KG	2.010W	1.547W	DIGITAL	230V-50Hz

PARA OTROS MEDIDAS Y ACABADOS , CONSULTAR DISPONIBILIDAD. - CHECK AVAILABILITY FOR OTHER MEASURES AND FINISHINGS - POUR AUTRES DIMENSIONS OU FINITIONS, CONSULTER LA DISPONIBILITÉ.

CON TERMÓMETRO ANALÓGICO EXTERIOR  
*EXTERNAL ANALOGICAL THERMOMETER*  
AVEC THERMOMÈTRE ANALOGIQUE EXTERNE

TERMOSTATO REGULABLE  
*ADJUSTABLE THERMOSTAT*  
THERMOSTAT RÉGLABLE

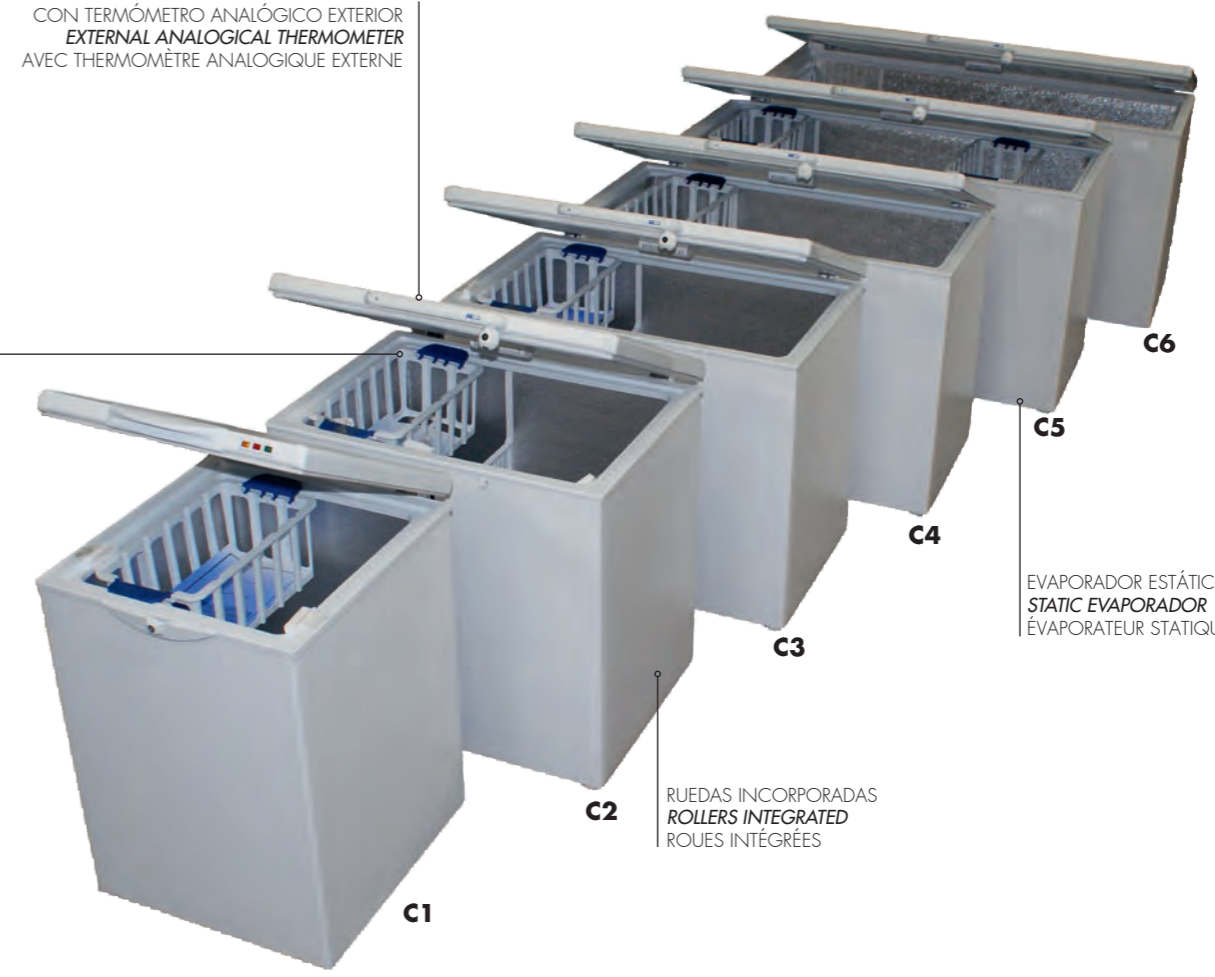

RUEDAS INCORPORADAS  
*ROLLERS INTEGRATED*  
ROUES INTÉGRÉES

EVAPORADOR ESTÁTICO  
*STATIC EVAPORATOR*  
ÉVAPORATEUR STATIQUE

**CONGELADORES**

	TIPO	RANGO	CAPACIDAD	DIMENSIONES	PESO	PUERTA	POTENCIA	VOLTAJE	RUEDAS	TERMOSTATO	CESTAS
<b>C1</b>	NEGATIVO	-18°C / -22°C	150LT	660x680x870	34KG	ABATIBLE	105W	230V-50HZ	SI	ANALOGICO	OPCIONAL
<b>C2</b>	NEGATIVO	-18°C / -22°C	240LT	890x680x870	38KG	ABATIBLE	148W	230V-50HZ	SI	ANALOGICO	1
<b>C3</b>	NEGATIVO	-18°C / -22°C	320LT	1050x680x870	44KG	ABATIBLE	192W	230V-50HZ	SI	ANALOGICO	1
<b>C4</b>	NEGATIVO	-18°C / -22°C	370LT	1240x680x870	50KG	ABATIBLE	217W	230V-50HZ	SI	ANALOGICO	1
<b>C5</b>	NEGATIVO	-18°C / -22°C	460LT	1450x680x870	58KG	ABATIBLE	217W	230V-50HZ	SI	ANALOGICO	2
<b>C6</b>	NEGATIVO	-18°C / -22°C	550LT	1640x680x870	6434KG	ABATIBLE	217W	230V-50HZ	SI	ANALOGICO	2



PROFESIONAL  
LINEA SNACK LIFE



MODELOS DISPONIBLES EN VERSIONES  
ELECTRICAS Y DE GAS  
**ELECTRICAL AND GAS VERSIONS AVAILABLE**  
MODÈLES DISPONIBLES EN VERSIONS  
ÉLECTRIQUE ET GAZ.

COMBINA DIFERENTES ACCESORIOS EN  
LA MISMA LINEA SNACK  
**IT COMBINES MULTIPLE AC-  
CESSORIES ON THE SAME LINE**  
COMBINE DIFFÉRENTS ACCESSOIRE  
DANS LA MÊME LIGNE SNACK

FABRICADAS EN ACERO INOX  
**MANUFACTURED IN STAINLESS STEEL**  
FABRIQUÉ EN ACIER INOX



CONSTRUCCIÓN DE EXTREMA  
ROBUSTEZ Y POTENCIA  
**EXTREMELY STURDY  
AND POWERFUL CONSTRUCTION**  
CONSTRUCTION D'UNE EXTRÊME  
ROBINETTERIE DE GRANDE PRÉCISION  
ROBUSTESSE ET DE PUISSANCE

GRIFERIA DE GRAN PRECISIÓN  
EQUIPADAS CON VÁLVULA DE SEGURIDAD  
**HIGH PRECISION PLUMBING  
EQUIPPED WITH A SAFETY VALVE**  
ROBINETS DE PRÉCISION ÉLEVÉE  
ÉQUIPÉ D'UNE VALVULE DE SÉCURITÉ

DISPONIBLES TAMBIEN  
EN PROFUNDIDAD 700 Y 900  
**700 AND 900 DEPTH ALSO AVAILABLE**  
DISPONIBLES ÉGALEMENT  
EN 700 ET 900 DE PROFONDEUR

LINEA SNACK





ELECTRIC



SLE46P



SLE66P



SLE86P



SLE46U



SLE36F



SLE46F



SLE66F



SLE46R



SLE66R



SLE86R



SLE46M



SLE46C



SLE46FO



SLE66PA

FRY-TOP SNACK LIFE -ELÉCTRICA-

	DESCRIPCIÓN	TIPO DE MÓDULO	MEDIDAS	TIPO	POTENCIA	VOLTAJE	PESO
<b>SLE46P</b>	FRY-TOP 400	ACERO	400X600X300	ELÉCTRICO	4.8KW	400 V	45 KG
<b>SLE66P</b>	FRY-TOP 600	ACERO	600X600X300	ELÉCTRICO	6.4KW	400 V	60 KG
<b>SLE86P</b>	FRY-TOP 800	ACERO	800X600X300	ELÉCTRICO	9.6KW	400 V	75 KG
<b>SLE46R</b>	FRY-TOP 400 - CROMO	CROMO	400X600X300	ELÉCTRICO	4.8KW	400 V	45 KG
<b>SLE66R</b>	FRY-TOP 600 - CROMO	CROMO	600X600X300	ELÉCTRICO	6.4KW	400 V	60 KG
<b>SLE86R</b>	FRY-TOP 800 - CROMO	CROMO	800X600X300	ELÉCTRICO	9.6KW	400 V	75 KG

LINEA SNACK LIFE -ELÉCTRICA-

	DESCRIPCIÓN	MEDIDAS	TIPO	POTENCIA	VOLTAJE	PESO
<b>SLE36F</b>	FREIDORA 9LITROS	300X600X300	ELÉCTRICO	7.5KW	400 V	18 KG
<b>SLE46F-M</b>	FREIDORA 12LITROS	400X600X300	ELÉCTRICO	9KW	230 V	25 KG
<b>SLE46F</b>	FREIDORA 12LITROS	400X600X300	ELÉCTRICO	9KW	400 V	28 KG
<b>SLE66F</b>	FREIDORA 9+9 LITROS	600X600X300	ELÉCTRICO	15KW	400 V	28 KG
<b>SLE46M</b>	MANTENEDOR GN2/3 1.50	400X600X300	ELÉCTRICO	1.0KW	230 V	22 KG
<b>SLE46C</b>	BAÑO MARÍA GN2/3 1.50	400X600X300	ELÉCTRICO	0.65KW	230 V	20 KG
<b>SLE46U</b>	CUECEPASTAS	400X600X300	ELÉCTRICO	5.0KW	400 V	28 KG
<b>SLE46FO</b>	2 FOGONES	400X600X300	ELÉCTRICO	4KW	400 V	25 KG
<b>SLE66PA</b>	PARRILLA ELECTRICA GRILL	600X600X300	ELÉCTRICO	7.5KW	400 V	32 KG



GAS



SLG46P



SLG66P



SLG86P



SLG36F



SLG46F



SLG66F



SLG86F



SLG46R



SLG66R



SLG86R



SLG46B



SLG66B



SLG86B



SLP2

FRY-TOP SNACK LIFE -GAS-

DESCRIPCIÓN	TIPO DE MÓDULO	MEDIDAS	TIPO	POTENCIA	Kcal	PESO
<b>SLG46P</b> FRY-TOP GAS 400	ACERO	400X600X300	GAS	4.5 KW	3.870 kcal	15 KG
<b>SLG66P</b> FRY-TOP GAS 600	ACERO	600X600X300	GAS	6.75 KW	5.805 kcal	22 KG
<b>SLG86P</b> FRY-TOP GAS 800	ACERO	800X600X300	GAS	9.0 KW	7.738 kcal	28 KG
<b>SLG46R</b> FRY-TOP GAS 400 - CROMO	CROMO	400X600X300	GAS	4.5 KW	3.870 kcal	15 KG
<b>SLG66R</b> FRY-TOP GAS 600 - CROMO	CROMO	600X600X300	GAS	6.75 KW	5.805 kcal	22 KG
<b>SLG86R</b> FRY-TOP GAS 800 - CROMO	CROMO	800X600X300	GAS	9.0 KW	7.738 kcal	28 KG

LINEA SNACK LIFE -GAS-

DESCRIPCIÓN	MEDIDAS	TIPO	POTENCIA	Kcal	PESO
<b>SLG46B</b> BARBACOA GAS 400	400X600X300	GAS	5 KW	4.299 kcal	50 KG
<b>SLG66B</b> BARBACOA GAS 600	600X600X300	GAS	7.5 KW	5.804 kcal	75 KG
<b>SLG86B</b> BARBACOA GAS 800	800X600X300	GAS	10 KW	7.738 kcal	96 KG
<b>SLG36F</b> FOGONES GAS 300	300X600X300	GAS	12.6 KW	10.834 kcal	20 KG
<b>SLG46F</b> FOGONES GAS 400	400X600X300	GAS	12.6 KW	10.834 kcal	24 KG
<b>SLG66F</b> FOGONES GAS 600	600X600X300	GAS	25.2 KW	21.668 kcal	30 KG
<b>SLG86F</b> FOGONES GAS 800	800X600X300	GAS	25.2 KW	21.668 kcal	37 KG
<b>SLP2</b> PAELLERO DE DOBLE CORONA	600X740X590	GAS	19 KW	16.337 kcal	56 KG

PROFESIONAL

LINEA SNACK LIFE

LINEA SNACK



SLN46



SLN46S

SLN66S

SLN106S

**LINEA SNACK LIFE MÓDULOS NEUTROS**

	DESCRIPCIÓN	MEDIDAS	TIPO	PESO
<b>SLN46</b>	CONTENEDOR NEUTRO	400X600X300	NEUTRO	15 KG
<b>SLN36S</b>	MUEBLE NEUTRO 300	300X550X560	NEUTRO	16 KG
<b>SLN46S</b>	MUEBLE NEUTRO 400	400X550X560	NEUTRO	18 KG
<b>SLN66S</b>	MUEBLE NEUTRO 600	600X550X560	NEUTRO	22 KG
<b>SLN86S</b>	MUEBLE NEUTRO 800	800X550X560	NEUTRO	26 KG
<b>SLN106S</b>	MUEBLE NEUTRO 1000	1000X550X560	NEUTRO	30 KG



EXCELENTE Y FACIL LIMPIEZA  
EXCELLENT AND EASY CLEANING  
EXCELLENTE FACILITÉ DE NETTOYAGE

EN 3 MINUTOS ALCANZA UNA TEMPERATURA DE 300°C  
IT REACHES A TEMPERATURE OF 300°C IN 3 MINUTES  
LA TEMPÉRATURE MONTE A 300°C EN 3 MINUTES

AHORRO EN EL COSUMO DE GAS AL NO REQUERIR QUE ESTE  
ENCENDIDA TODA LA JORNADA  
GAS SAVING AS IT DOES NOT NEED TO BE SWITCHED ON THE  
ENTIRE DAY  
ÉCONOMIE DE CONSOMMATION DE GAZ A CONDITION QUE  
CELA NE SOIT PAS ALLUMÉ TOUTE LA JOURNÉE.

PLACA VITROCERAMICA EXTRAIBLE PARA FACILITAR LA LIMPIEZA  
REMOVABLE VITROCERAMIC HOB FOR EASY CLEANING PLAQUE  
VITROCÉRAMIQUE RETIRABLE FACILITANT LE NETTOYAGE

PETO DE ACERO INOXIDABLE  
STAINLESS STEEL SPLASHGUARD  
CORPS EN ACIER INOXYDABLE



PVI40

PVI60

PVI80

SIN MEZCLA DE SABORES GRACIAS A SU SUPERFICIE NO POROSA  
UNMIXED FLAVOURS THANKS TO ITS POROUS SURFACE  
SANS MÉLANGE DES SAVEURS GRÂCE A SA SUPERFICIE NON POREUSE!

TEMPERATURA MÁXIMA DE 440°C  
MAXIMUM TEMPERATURE OF 440°C  
TEMPÉRATURE MAXIMUM DE 440°C

PROFESIONAL

VITROCERÁMICAS A GAS

**PLANCHAS A GAS VITROCERÁMICAS**

	MEDIDAS	MEDIDAS PLACA VITRO	TIPO	NºQUEMADORES	POTENCIA	GRIFOS
<b>PVI40</b>	440X500X290	400X400	A GAS	2	5.2KW	2
<b>PVI60</b>	640X500X290	600X400	A GAS	3	7.70KW	2
<b>PVI80</b>	840X500X290	800X400	A GAS	4	10.30KW	2

VITROCERÁMICA A GAS

PETO SOLDADO AL MÓDULO POR LA PARTE SUPERIOR, EN TODOS LOS MODELOS  
**EDGE WELDED AT THE TOP OF THE MODULE IN ALL MODELS**  
 MODULE DE PETO SOUDÉ À LA PARTIE SUPÉRIEURE DANS TOUS LES MODÈLES

FOGÓN DE GRAN CALIDAD  
 COMBINABLE CON TODOS LOS MODELOS  
**HIGH QUALITY STOVE COMBINABLE  
 IN ALL MODELS**  
 FEU DE GRANDE QUALITÉ  
 COMBINABLE AVEC TOUS LES MODÈLES

2 ACABADOS - ROYAL -CROMO  
**2 FINISHINGS: ROYAL-CHROME**  
 2 TERMINÉS- ROYAL -CHROME

GRIFERIA DE GRAN PRECISIÓN  
 EQUIPADAS CON VÁLVULA DE SEGURIDAD  
**HIGH PRECISION PLUMBING  
 EQUIPPED WITH A SAFETY VALVE**  
 ROBINETS DE PRÉCISION ÉLEVÉE  
 ÉQUIPÉ D'UNE VALVULE DE SÉCURITÉ

FABRICADAS EN ACERO INOX  
**MANUFACTURED IN STAINLESS STEEL**  
 FABRIQUÉES EN ACIER INOX

PIES REGULABLES EN ALTURA  
**HEIGHT-ADJUSTABLE FEET**  
 PIEDS RÉGLABLES EN HAUTEUR

**30cm**

**60cm**

**90cm**

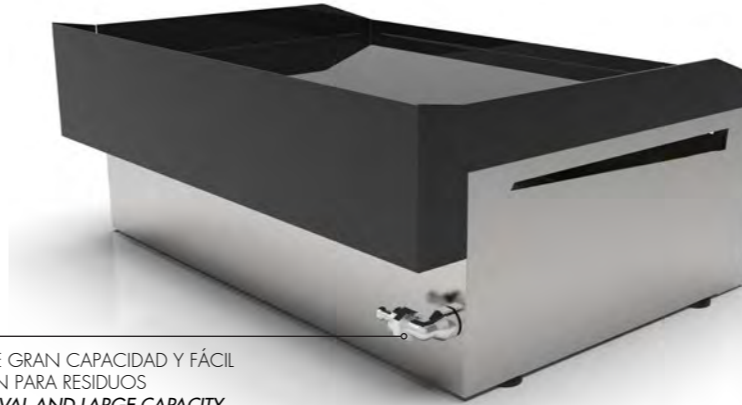

GRASERA DE GRAN CAPACIDAD Y FÁCIL EXTRACCIÓN PARA RESIDUOS  
**EASY REMOVAL AND LARGE CAPACITY  
 GREASE FITTING FOR WASTE**  
 CONTENEURS POUR GRAISSE DE GRANDE CAPACITÉ ET FACILE ENLÈVEMENT



GRASERA DE GRAN CAPACIDAD Y FÁCIL EXTRACCIÓN PARA RESIDUOS  
**EASY REMOVAL AND LARGE CAPACITY  
 GREASE FITTING FOR WASTE**  
 CONTENEURS POUR GRAISSE DE GRANDE CAPACITÉ ET FACILE ENLÈVEMENT



	MEDIDAS	TIPO	Nº QUEMADORES	NºFOGONES	POTENCIA
<b>P30F</b>	300/370X400X200	A GAS	-	1	3.6KW
<b>P60F2</b>	600/670X400X200	A GAS	-	2	7.2KW
<b>P90F3</b>	900/970X400X200	A GAS	-	3	10.8KW



GAS '60F



POSIBILIDAD DE MODULO FRANKURT EN TODOS LOS MODELOS  
POSSIBILITY OF A FRANKFURT MODULE IN ALL MODELS  
POSSIBILITÉ DE MODULE DE FRANKFURT

PROFESIONAL  
PLANCHAS A GAS

PLANCHAS ROYAL

	MEDIDAS	TIPO	Nº QUEMADORES	Nº FOGONES	POTENCIA
<b>P30</b>	300/370X400X200	A GAS	1	-	3.6KW
<b>P60</b>	600/670X400X200	A GAS	2	-	7.2KW
<b>P90</b>	900/970X400X200	A GAS	3	-	10.8KW
<b>P60F</b>	600/670X400X200	A GAS	1	1	7.2KW
<b>P90F</b>	900/970X400X200	A GAS	2	1	10.8KW
<b>P90F2</b>	900/970X400X200	A GAS	1	2	10.8KW

PLANCHAS CROMO

	MEDIDAS	TIPO	Nº QUEMADORES	Nº FOGONES	POTENCIA
<b>PC30</b>	300/370X400X200	A GAS	1	-	3.6KW
<b>PC60</b>	600/670X400X200	A GAS	2	-	7.2KW
<b>PC90</b>	900/970X400X200	A GAS	3	-	10.8KW
<b>PC60F</b>	600/670X400X200	A GAS	1	1	7.2KW
<b>PC90F</b>	900/970X400X200	A GAS	2	1	10.8KW
<b>PC90F2</b>	900/970X400X200	A GAS	1	2	10.8KW



PARRILLA ACANALADA DE ACERO INOXIDABLE  
STAINLESS STEEL ANGLED CAST  
PLAQUE CANNELÉE EN ACIER INOX

QUEMADORES TUBULARES POLIDORO DE ACERO INOXIDABLE  
STAINLESS STEEL TUBULAR POLIDORO BURNERS  
BRÛLEURS TUBULAIRES EN ACIER INOXYDABLE.



AJUSTABLE A 3 ALTURAS  
3 SCALED MOVEMENT COOKING SURFACE  
AJUSTABLE EN 3 HAUTEURS.

PIES NIVELADOS REGULABLES EN ALTURA  
ADJUSTABLE HEIGHT FEET  
PIEDS RÉGLABLES EN HAUTEUR.

POSIBILIDAD DE INCORPORAR PETO EN CUALQUIER  
MOMENTO PARA COCINAR EN 3 ALTURAS SIMULTÁNEAS  
OPTIONAL SPLASHGUARD CAN BE INCORPORATED  
ANYTIME TO COOK SIMULTANEOUSLY IN 3 HEIGHTS  
POSSIBILITÉ D'INCORPORER UN REBORD A N'IMPORTE QUEL  
MOMENT POUR CUISINER SUR 3 HAUTEURS SIMULTANÉES



PLANCHA OPCIONAL DE HIERRO FUNDIDO  
OPTIONAL CAST IRON  
FONTE EN FONTE EN OPTION

7.5KW

FOGÓN DE GRAN POTENCIA  
HIGH POWERFUL STOVE  
FEU DE GRANDE PUISSANCE



COC-1

15KW

FOGÓN DE GRAN POTENCIA  
HIGH POWERFUL STOVE  
FEU DE GRANDE PUISSANCE



COC-2

PARRILLA DE HIERRO FUNDIDO  
CAST-IRON COOKING GRID  
GRILLE EN FONTE

FABRICADAS EN ACERO INOX  
MANUFACTURED IN STAINLESS STEEL  
FABRIQUÉ EN ACIER INOX

GRIFERIA DE GRAN PRECISIÓN  
EQUIPADAS CON VÁLVULA DE SEGURIDAD  
HIGH PRECISION PLUMBING  
EQUIPPED WITH A SAFETY VALVE  
ROBINETS DE PRÉCISION ÉLEVÉE  
ÉQUIPÉ D'UNE VALVULE DE SÉCURITÉ

BARBACOA A GAS DE PIEDRA VOLCÁNICA

	MEDIDAS EXTERIORES	MEDIDAS PARRILLA	TIPO	Nº QUEMADORES	Nº GRIFOS	POTENCIA	BOLSA LAVA 4KG
<b>BAR-35</b>	370X600X260	280X500	A GAS	2	1	7.2KW	1
<b>BAR-60</b>	600X600X260	530X500	A GAS	4	2	14.4KW	2
<b>BAR-90</b>	900X600X260	830X500	A GAS	6	3	21.6KW	3

COCINAS A GAS DE GRAN POTENCIA

	MEDIDAS	TIPO	Nº FOGONES	POTENCIA	PESO
<b>COC-1</b>	390X600X250	A GAS	1	7.5KW	16 KG
<b>COC-2</b>	740X600X250	A GAS	2	15KW	26 KG
<b>COC-3</b>	1090X600X250	A GAS	3	22.5KW	37 KG



ELECTRIC

GRILLS CONSTRUIDOS EN ACERO INOXIDABLE  
**STAINLESS STEEL GRILLS**  
GRILLS CONSTRUITS EN ACIER INOXYDABLE



GR02



GR22

SUPERFICIE ANTIADHERENTE  
**NON-STICK SURFACE**  
SURFACE ANTIADHÉRENTE

PETOS LATERALES Y TRASERO ANTISALPICADURAS  
**COVERALL SPLASH EDGE LATERAL AND BACK**  
REBORDS LATÉRAUX ET ARRIÈRE ANTI ÉCLABOUSSURES



PEC40

CAJÓN RECOGEGRASAS EXTRAÍBLE  
**REMOVABLE FAT TRAY**  
TIROIR RAMASSE GRAISSES EXTRACTIBLE

PLACA DE CROMO DE 12MM Y 12 MICRAS  
**12MM AND 12 MICRO CHROME PLATE**  
12MM ET 12 PLAQUE MICRO CHROME



PEC60

CONTROL AUTOMÁTICO DE LA TEMPERATURA  
**AUTOMATIC TEMPERATURE CONTROL**  
CONTROLE AUTOMATIQUE DE LA TEMPÉRATURE

PLACAS DE ACERO FORJADOS ACANALADAS O LISA  
**RIBBED OR FLAT FORGED STEEL PLATE**  
PLAQUES EN FER FORGÉ CANNELÉES OU LISSES



GR01



GR11

FÁCIL LIMPIEZA  
**EASY CLEANING**  
NETTOYAGE FACILE

GRILLS ELÉCTRICOS

	POTENCIA	DIMENSIONES	VOLTAJE	DIM. GRILL SUPERIOR	DIM. GRILL INFERIOR	TEXTURA GRILL SUPERIOR	TEXTURA GRILL INFERIOR
<b>GR01</b>	1.800W	320x410x190	230V-50Hz	214x214	218x230	ACANALADO	ACANALADO
<b>GR11</b>	2.200W	440x410x190	230V-50Hz	340x220	340x230	ACANALADO	ACANALADO
<b>GR02</b>	3.600W	580x410x190	230V-50Hz	214x214 (2)	475x230	ACANALADO	ACANALADO
<b>GR22</b>	3.600W	580x410x190	230V-50Hz	214x214 (2)	475x230	ACANALADO	LISO

PLANCHA CROMO ECO

	MEDIDAS	TIPO	CONTROL TEMPERATURA	POTENCIA	VOLTAJE	TIPO DE MODULO	MICRAS CROMO	GRASERA EXTRAIBLE
<b>PEC40</b>	400X500X270	ELECTRICO	SI	3KW	230V - 50Hz	CROMO 12MM	12 MICRAS	DELANTERA
<b>PEC60</b>	600X500X270	ELECTRICO	SI	3KW	230V - 50Hz	CROMO 12MM	12 MICRAS	DELANTERA

CONSTRUIDA CON LOS MEJORES COMPONENTES PARA OBTENER LA MÁXIMA FIABILIDAD  
 BUILT WITH THE BEST COMPONENTS FOR THE MAXIMUM RELIABILITY  
 CONSTRUITE AVEC LES MEILLEURS COMPOSANTS POUR OBTENIR UNE FIABILITÉ MAXIMALE

### CABEZALES SAYL

CABEZALES	FREIDORA	POTENCIA	VOLTAJE
<b>CB4G</b>	F4 G/ F44G	1.800W	230V
<b>CB8G</b>	F8G / F88G	3.000W	230V
<b>CB10</b>	F10	3.500W	230V
<b>CB15</b>	F8 / F15	3.500W	230V

FABRICADAS EN ACERO INOX  
 MANUFACTURED IN AISI 304 STAINLESS STEEL  
 FABRIQUÉ EN ACIER INOX



**F4G**

TERMOSTATO DE TEMPERATURAS  
 TEMPERATURE THERMOSTAT  
 THERMOSTAT DE TEMPÉRATURES



**F10F**

CABEZAL EXTRAIBLE CON MICROINTERRUPTOR DE DESCONEXIÓN  
 REMOVABLE HEAD WITH A DISCONNECTION MICRO SWITCH  
 TÊTE EXTRACTION AVEC MICRO INTERRUPTEUR DE DÉCONNEXION



**F88G**

GRIFO DE VACIADO EN CUBA  
 EN MODELOS INDICADOS  
 DRAINING TAP IN SELECTED  
 MODELS  
 ROBINET DE VIDANGE DE LA  
 CUVE SUR LES MODÈLES  
 INDIQUÉS.



**F6X**



**F9X**

REJILLA PERFORADA EN CUBA  
 PERFORATED GRID  
 GRILLE PERFORÉE DANS LA CUVE



**F99X**

CABEZAL DESMONTABLE  
 REMOVABLE HEAD  
 TÊTE DÉMONTABLE

### FREIDORAS ELÉCTRICAS SAYL

	CAPACIDAD	POTENCIA	VOLTAJE	COTA A	COTA B	COTA C	COTA D	COTA E
<b>F4G</b>	4 LITROS	1.800W	230V	175	325	420	230	295
<b>F44G</b>	4 + 4 LITROS	1.800W + 1800W	230V	350	325	420	230	295
<b>F8G</b>	8 LITROS	3.000W	230V	265	325	420	230	295
<b>F88G</b>	8 + 8 LITROS	3.000W + 3.000W	230V	530	325	420	230	295
<b>F10G</b>	10 LITROS	3.500W	230V	355	325	420	230	295

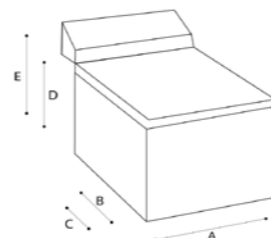

### FREIDORAS ELÉCTRICAS ECO

	CAPACIDAD	POTENCIA	VOLTAJE	DIMENSIONES	DIMENSIONES CESTA	GRIFO
<b>F6X</b>	6 LITROS	3.000W	230V-50Hz	290x440x290	200x220x100	NO
<b>F9X</b>	9 LITROS	3.000W	230V-50Hz	310x480x345	200x220x100	SI
<b>F66X</b>	6+6 LITROS	3.000W	230V-50Hz	310x480x345	200x220x100	NO
<b>F99X</b>	9+9 LITROS	3.000W	230V-50Hz	310x480x345	200x220x100	SI



TOSTADOR IDEAL PARA BUFFETS Y HOTELES  
**TOASTER PERFECT FOR BUFFETS AND HOTELS**  
 GRILLE-PAIN PARFAIT POUR LES BUFFETS ET LES HOTELS

TOSTADOR DE PAN DE CUALQUIER FORMATO  
*IT CAN TOAST ANY KIND OF BREAD*  
 FABRIQUÉ EN ACIER INOX

**TR- GIRATORIO**

REDUCIDAS DIMENSIONES Y GRAN PRODUCCIÓN (250 TOSTADAS/HORA)  
*SMALL DIMENSIONS AND GREAT PRODUCTIVITY (250 TOASTS PER HOUR)*  
 DIMENSIONS RÉDUITES ET GRANDE PRODUCTION (250 TOASTS / HEURE)

CONSTRUIDAS EN ACERO INOXIDABLE  
*MANUFACTURED IN STAINLESS STEEL*  
 CONSTRUIT EN ACIER INOXYDABLE

RESISTENCIAS BLINDADAS  
*ARMOURED RESISTANCES*  
 RÉSTANCES BLINDÉES

RESISTENCIAS INDEPENDIENTES PARA TOSTAR  
 AMBAS CARAS O ÚNICAMENTE GRATINAR  
*INDEPENDENT RESISTANCES*  
**TO TOAST BOTH SIDES OR JUST GRILL**  
 RÉSTANCES INDÉPENDANTES POUR TOASTER DES  
 DEUX COTÉS OU GRATINER UNIQUEMENT

BANDEJA RECOJEMIGAS  
*REMOVABLE CRUMB TRAY*  
 PLATEAU RAMASSE MIETTES

	DIMENSIONES	POTENCIA	TIPO DE RESISTENCIAS	BANDEJA RECOJEMIGAS	ACABADO	VOLTAJE	PIES
<b>TR</b>	380x400x270	1.800W	BLINDADAS	SI	ACERO INOXIDABLE	230V-50HZ	SI



**TOSTADOR 1P CUARZO - (1TPX)**  
 ALTURA BOCA 7CM  
 CON TEMPORIZADOR



**TOSTADOR 2P CUARZO - (2TPX)**  
 ALTURA BOCA 7CM  
 CON TEMPORIZADOR



**TOSTADOR 4P BLINDADO - TH4**  
 IDEAL PIZZAS Y PAELLAS  
 MEDIDA PARRILLA : 310x300mm  
 ALTURA MÁXIMA : 70mm  
 TEMPORIZADOR  
 5 RESISTENCIAS  
 CON AVISADOR



**TOSTADOR 2P BLINDADO - TH2**



**TOSTADOR DE CINTA (TCTX)**  
 1.50 TOSTADAS /HORA  
 VELOCIDAD REGULABLE  
 SELECTOR DE RESISTENCIAS



**SALAMANDRA60 - (SA60X)**  
 MEDIDA PARRILLA : 450x250mm  
 TEMPORIZADOR 1.5 MIN



**SALAMANDRA TECHO MÓVIL (SA90M)**  
 MEDIDA PARRILLA : 557x325mm  
 ALTURA MÁXIMA : 220mm  
 CABEZAL REGULABLE  
 2 ZONAS INDEPENDIENTES DE CALOR

**TOSTADORES**

	DIMENSIONES	POTENCIA	TIPO DE RESISTENCIAS	BANDEJA RECOJEMIGAS	ACABADO	VOLTAJE	PIES
<b>1TPX</b>	440x260x290	1.700W	CUARZO	SI	ACERO INOXIDABLE	230V-50HZ	SI
<b>2TPX</b>	440x260x400	3.000W	CUARZO	SI	ACERO INOXIDABLE	230V-50HZ	SI
<b>TH2</b>	500x250x320	3.600W	BLINDADAS	SI	ACERO INOXIDABLE	230V-50HZ	SI
<b>TH4</b>	410x330x460	3.500W	BLINDADAS	SI	ACERO INOXIDABLE	230V-50HZ	SI
<b>TCTX</b>	420x370x390	2.240W	BLINDADAS	SI	ACERO INOXIDABLE	230V-50HZ	SI
<b>SA60X</b>	610x345x280	2.000W	BLINDADAS	SI	ACERO INOXIDABLE	230V-50HZ	SI
<b>SA90M</b>	625x515x530	4.000W	BLINDADAS	SI	ACERO INOXIDABLE	230V-50HZ	SI

PROFESIONAL

TOSTADORES

TOSTADORES

CONSTRUIDAS EN ACERO INOXIDABLE  
MANUFACTURED IN STAINLESS STEEL  
CONSTRUIT EN ACIER INOXYDABLE

6 NIVELES DE POTENCIA  
6 POWER LEVELS  
6 NIVEAUX DE PUISSANCE

MI-05



ALCANZAN SU PLENA POTENCIA MÁS RAPIDAMENTE QUE LOS MICROONDAS DOMESTICOS  
REACH THEIR FULL POWER MORE QUICKLY THAN DOMESTIC MICROWAVES.  
IL ATTEINT SA PLEINE PUISSANCE PLUS RAPIDEMENT QUE LES MICRO-ONDES MÉNAGERS

APILABLES  
STACKABLE  
EMPILABLES

MI-20



PARA TRABAJAR INTESAMENTE DURANTE LARGOS PERIODOS DE TIEMPO  
ARE DESIGNED TO WORK INTENSELY FOR LONG PERIODS OF TIME  
POUR TRAVAILLER INTENSÉMENT DURANT DE GRANDES PÉRIODES DE TEMPS

DOBLE MAGNETRÓN DE PROYECCIÓN DESDE ARRIBA  
QUE GARANTIZA UNA COCCIÓN UNIFORME  
DUAL MAGNETRON TOP FEEDING MICROWAVE  
DISTRIBUTIONENSURES EVEN COOKING  
MAGNÉTRON A DOUBLE PROJECTION DEPUIS LE  
HAUT GARANTISSANT UNE CUISSON UNIFORME

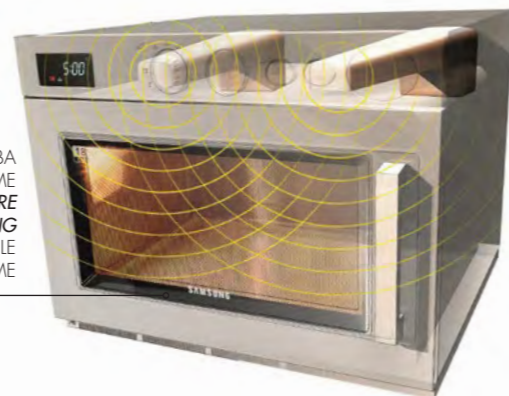

SIN PLATO GIRATORIO PARA MAYOR CAPACIDAD  
WITHOUT TURNTABLE FOR GREATER CAPACITY  
SANS PLATEAU TOURNANT POUR UNE MEILLEURE CAPACITÉ

MI-10



ZONA DE COCCIÓN GN2/3  
COOKING ZONE GN2/3  
ZONE DE CUISSON GN2/3

H-G3X

BANDEJA 600x400 MM  
PANADERÍA



H-G4X

BANDEJA 600x400 MM  
PANADERÍA



H-G2X

BANDEJA 315x435 MM



PROFESIONAL

HORNOS

HORNOS MICROONDAS

TIPO	CAPACIDAD	CONTROL	TENSIÓN	POTENCIA	DIMENSIONES		PESO	
					EXTERIORES	INTERIORES		
MI-05	ELECTRICO	24 LT	MANUAL	230V - 50HZ	900 W	483X400X281	340X320X220	18KG
MI-10	ELECTRICO	26 LI	MANUAL	230V - 50HZ	1.100 W	514X380X295	330X310X200	18KG
MI-20	ELECTRICO	26 LI	MANUAL	230V - 50HZ	1.500 W	464X559X372	370X370X200	32KG

HORNOS APERTURA SUPERIOR

	Nº BANDEJAS	ACABADO	TENSIÓN	POTENCIA	TEMP. MAX	DIMENSIONES	BANDEJA	ALTURA BOCA	DOBLE PUERTA	TEMPORIZADOR	VENTILADORES	HUMIDIFICADOR	PESO
H-G2X	4	ACERO INOX	230V - 50HZ	2.7KW	300°C	595x530x570mm	315x435mm	70mm	SI	0-120MIN	2	NO	38KG
H-G3X	3	ACERO INOX	230V - 50HZ	3.5KW	300°C	835x765x500mm	600x400mm	80mm	SI	0-120MIN	2	NO	50KG
H-G4X	4	ACERO INOX	230V - 50HZ	6.5KW	300°C	835x765x570mm	600x400mm	80mm	SI	0-120MIN	2	SI	67KG

HORNOS MIXTOS DE CONVECCIÓN Y VAPOR PARA GASTRONOMÍA PAN Y PASTERÍA  
**CONVECTION AND STEAM MIXED OVEN FOR GASTRONOMY, BREAD AND BAKERY**  
 FOURS MIXTES A CONVECTION ET A VAPEUR POUR GASTRONOMIE PAIN ET PÂTISSERIE

SE SUMINISTRA CON 4 PARRILLAS GN 1/1  
**WITH 4 GN 1/1 GRILLS**  
 FOURNI AVEC 4 GRILLES GN 1/1

DOTADO DE HUMIDIFICADOR  
**EQUIPPED WITH AN HUMIDIFIER**  
 ÉQUIPÉ D'HUMIDIFICATEUR

1 TURBINA DE ALTAS PRESTACIONES  
**1 HIGH PERFORMANCE TURBINE**  
 1 TURBINE DE HAUTE PRESTATION

TEMPERATURA DE 50°C A 270°C  
**50°C A 270°C TEMPERATURE**  
 TEMPÉRATURE DE 50°C A 270°C

CONSTRUIDAS EN ACERO INOXIDABLE  
**BUILT IN STAINLESS STEEL**  
 CONSTRUIT EN ACIER INOXYDABLE

PUERTA LATERAL CON DOBLE CRISTAL TEMPLADO  
**DOUBLE TEMPERED GLASS LATERAL DOOR**  
 PORTE LATÉRALE DOUBLE VITRAGE EN VERRE TREMPÉ

RESISTENCIAS INFERIORES Y SUPERIORES  
**TOP AND BOTTOM RESISTANCE**  
 RÉSISTANCES SUPÉRIEURE ET INFÉRIEURE



**HH-GX PROFESIONAL**  
 GN - 600 X 400MM



**H-BRA-N**

20KG DE CARNE/HORA  
**20KG OF MEAT / HOUR**  
 20 KG DE VIANDE A L'HEURE

SE SUMINISTRA CON PARRILLA 530X570  
**IT IS SUPPLIED WITH A 530X570 GRILL**  
 FOURNI AVEC GRILLES 530X570

CUERPO AISLADO  
**ISOLATED BODY**  
 CORPS ISOLÉ



**H-BRA-R**

CONSTRUIDAS EN ACERO INOXIDABLE  
**BUILT IN STAINLESS STEEL**  
 CONSTRUIT EN ACIER INOXYDABLE

TEMPERATURA DE 250°C A 350°C  
**250°C A 350°C TEMPERATURE**  
 TEMPÉRATURE DE 250°C A 350°C

CAJÓN DE CENIZAS  
**ASH TRAY**  
 TIROIR A CENDRES

CAPUCHA DE SERIE  
**HOOD SERIES**  
 CHEMINÉE DE SÉRIE



ACCESORIO INFERIOR H-BRA-1  
**BOTTOM ACCESSORY H-BRA-1**  
 ACCESSOIRE INFÉRIEUR H-BRA-1



ACCESORIO INFERIOR H-BRA-2  
**BOTTOM ACCESSORY H-BRA-2**  
 ACCESSOIRE INFÉRIEUR H-BRA-2



ACCESORIO PARRILLA  
**GRILL ACCESSORY**  
 ACCESSOIRE DE GRIL

**HORNOS BRASA**

	COLOR PUERTA	ACADABO	TEMP. MAX	DIMENSIONES	PARRILLA	TERMOMETRO	CAJÓN DE CENIZAS	CUERPO AISLADO	PESO
<b>H-BRA-R</b>	ROJO	ACERO INOX	250-350°C	710x730x666/1271 mm	560x524mm	SI	SI	NO	160KG
<b>H-BRA-N</b>	NEGRO	ACERO INOX	250-350°C	710x730x666/1271 mm	560x524mm	SI	SI	NO	160KG
<b>H-BRA-BR</b>	ROJO	ACERO INOX	250-350°C	890x825x648/1271 mm	740x650mm	SI	SI	NO	190KG
<b>H-BRA-BN</b>	NEGRO	ACERO INOX	250-350°C	890x825x648/1271 mm	740x650mm	SI	SI	NO	190KG

**HORNO GASTRONOMIA PROFESIONAL**

	TIPO	CAPACIDAD	DISTANCIA BANDEJAS	TENSIÓN	POTENCIA	TEMP. MAX	DIMENSIONES INT.	DIMENSIONES EXT.	PESO
<b>HH-GX</b>	ELECTRICO	4 PARRILLAS 1/1	60-65	230V - 50HZ	3.1KW	270°C	552X430X418	796X670X580	70KG

PROFESIONAL

HORNOS

HORNOS

PANEL FRONTAL Y PUERTA EN ACERO INOX  
STAINLESS STEEL DOOR AND FRONTAL PANEL  
PANNEAU FRONTAL ET PORTE EN ACIER INOX

RESISTENCIAS BIINDADAS  
ARMoured RESISTANCES  
RÉSISTANCES BIINDÉES

HORNO 2 PIZZAS  
2 PIZZAS OVEN  
FOUR 2 PIZZAS

PANEL FRONTAL Y PUERTA EN ACERO INOX  
STAINLESS STEEL DOOR AND FRONTAL PANEL  
PANNEAU FRONTAL ET PORTE EN ACIER INOX

CRISTAL REFORZADO DE ALTA TEMPERATURA  
HIGH TEMPERATURE REINFORCED GLASS  
VITRE RENFORCÉE A HAUTE TEMPÉRATURE

SUELO DE PIEDRA REFRACTARIAS DE 12MM  
12 MM REFRACTORY STONE FLOOR  
SOL EN PIERRE RÉFRACTAIRE DE 12MM

SUELO DE PIEDRA REFRACTARIAS DE 14MM  
STONE FLOOR  
14MM REFRACTORY STONE  
SOL EN PIERRE RÉFRACTAIRE DE 14MM

RESISTENCIA INFERIORES Y SUPERIORES CON TERMOSTATOS SEPARADOS  
TOP AND BOTTOM RESISTANCE WITH SEPARATE THERMOSTAT  
RÉSISTANCES INFÉRIEURE ET SUPÉRIEURE AVEC THERMOSTATS SÉPARÉS

HORNO 2 PIZZAS CON DOBLE PUERTA  
DOUBLE DOOR 2 PIZZAS OVENS  
FOUR 2 PIZZAS AVEC DOUBLE PORTE

#### HORNOS PIZZA ECO

	MEDIDAS	MEDIDAS INTERIORES	POTENCIA	DIAM. PIZZA	VOLTAJE
HP 33X	515X465X365	300X330X2	1.800W	2 X 33 CM	230V
HP 40X	585X570X430	400X400X115X2	2.400W	2X40 CM	230V

SUELO DE COCCIÓN DE PIEDRA DE 14MM  
14 MM REFRACTORY STONE FLOOR  
SOL DE CUISSON EN PIERRE RÉFRACTAIRE DE 14MM

HORNOS PIZZA 1 CÁMARA  
ONE CHAMBER PIZZA OVEN  
FOURS PIZZAS 1 CHAMBRE

PANEL FRONTAL Y PUERTA DE ACERO INOX  
STAINLESS STEEL DOOR AND FRONTAL PANEL  
PANNEAU FRONTAL ET PORTE EN ACIER INOX

CÁMARA DE CHAPA DE ACERO ALUMINIZADA  
SHEET STEEL ALUMINIUM CHAMBER  
CHAMBRE AVEC PLAQUE D'ACIER D'ALUMINIUM

CRISTAL REFORZADO DE ALTA TEMPERATURA  
HIGH TEMPERATURE REINFORCED GLASS  
VITRE RENFORCÉE A HAUTE TEMPÉRATURE

LUZ INTERIOR DE LARGA VIDA  
LONG-LASTING INTERIOR LIGHT  
LUMIÈRE INTÉRIEURE LONGUE VIE

COCCIÓN RÁPIDA EN 5 MINUTOS  
5 MINUTES QUICK COOKING  
CUISSON RAPIDE EN 5 MINUTES

#### HORNOS PIZZA 1 CÁMARA

	MEDIDAS	MEDIDAS INTERIORES	POTENCIA	DIAM. PIZZA	VOLTAJE
HP 66X	975X945X415	660X660X135	4.500W	4 X 33CM	230V
HP 99X	975X1230X415	660X990X135	6.900W	6 X 33CM	230V

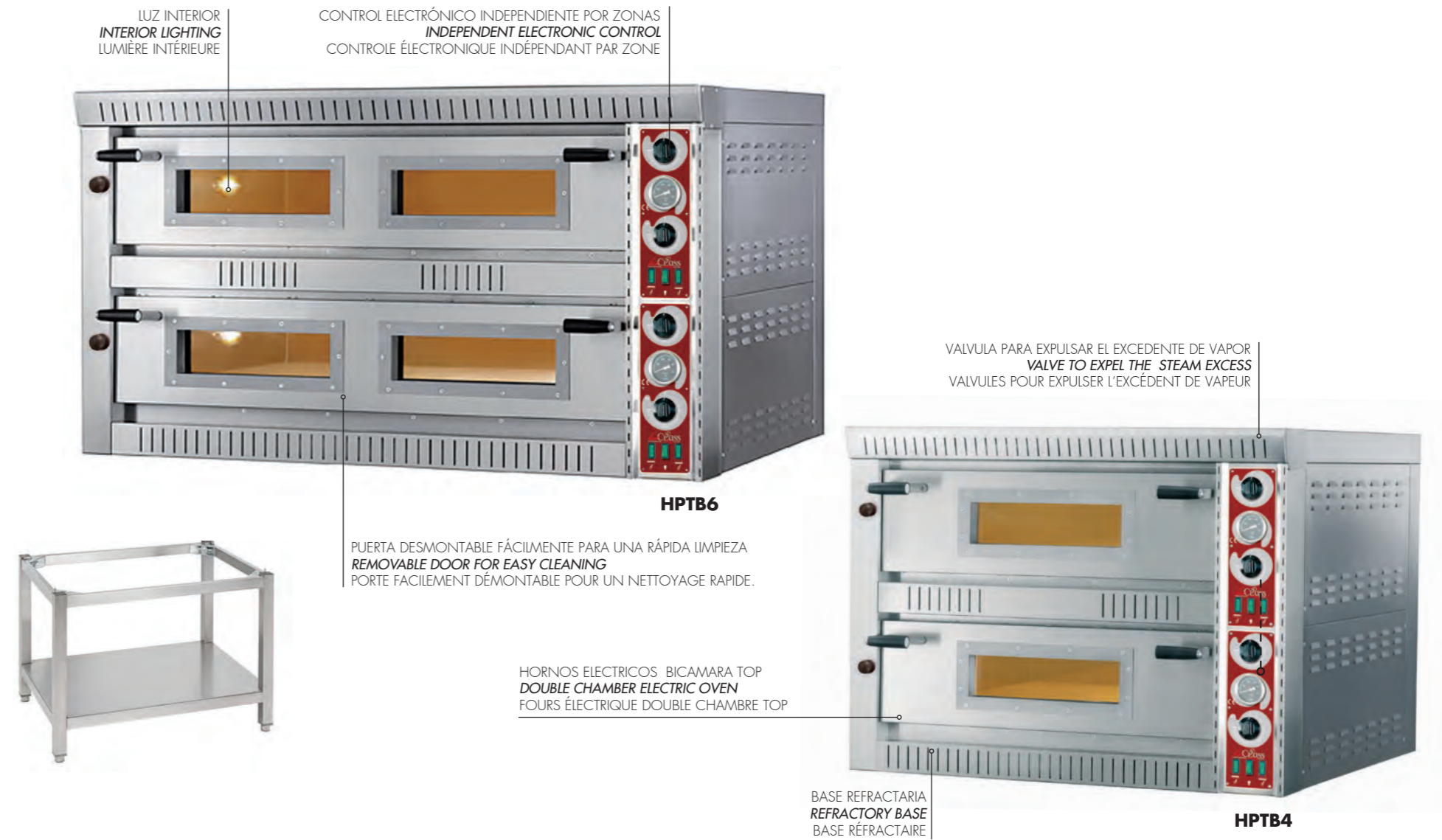
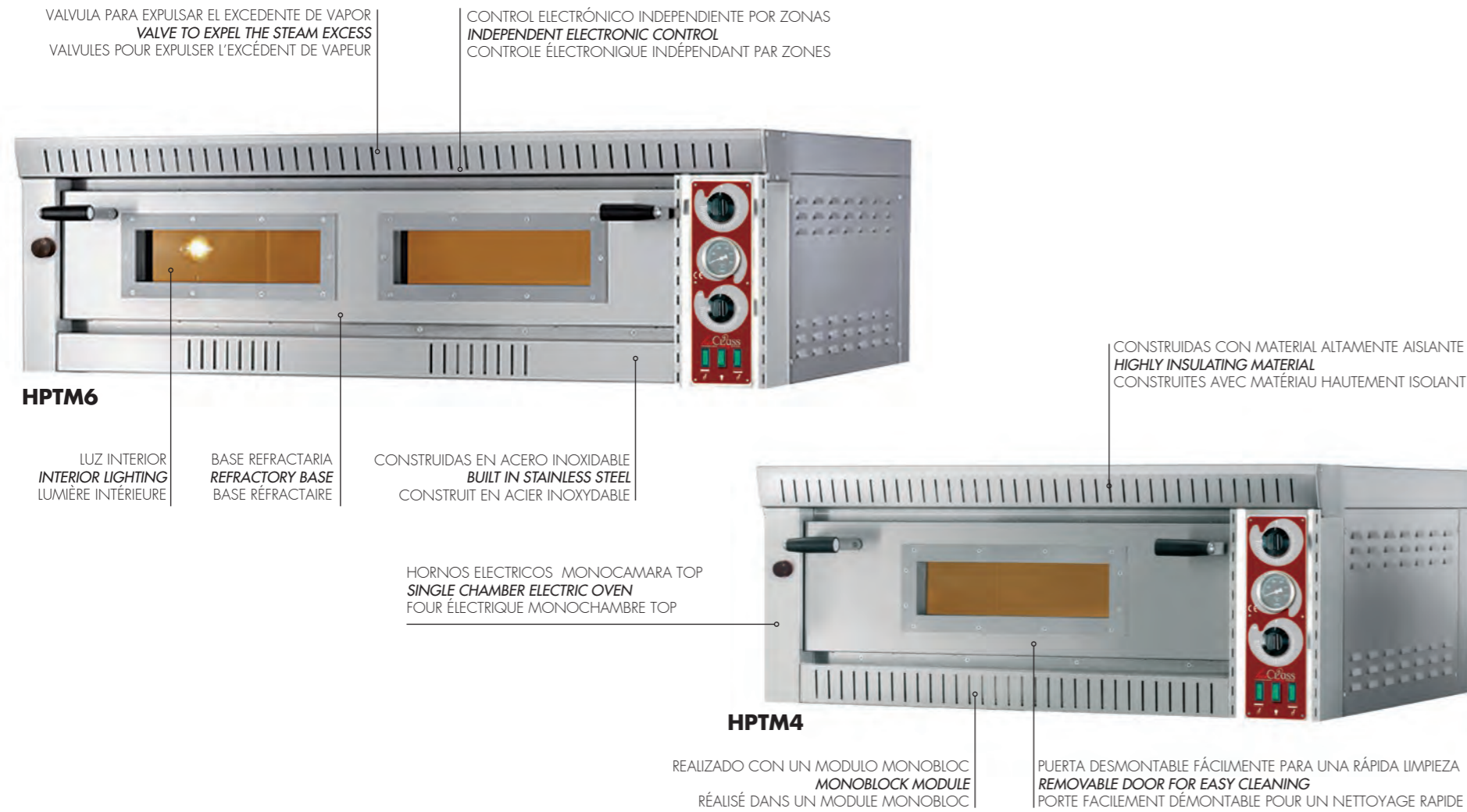

**HORNOS PIZZA PROFESIONAL MONOCAMARA**

	Nº CAMARAS	Nº PIZZAS	DIMENSIONES		POTENCIA	VOLTAJE	PESO	VALVULA VAPOR	TEMPERATURA MIN/MAX
			INTERIORES	EXTERIORES					
<b>HPTM4</b>	1	4	700X700X150	1014X1120X430	4.8KW	380V	80 KG	INCLUIDA	60°C/450°C
<b>HPTM6</b>	1	6	1050X700X150	1363X1120X430	7.2KW	380V	105 KG	INCLUIDA	60°C/450°C

**HORNOS PIZZA PROFESIONAL BICAMARA**

	Nº CAMARAS	Nº PIZZAS	DIMENSIONES		POTENCIA	VOLTAJE	PESO	VALVULA VAPOR	TEMPERATURA MIN/MAX
			INTERIORES	EXTERIORES					
<b>HPTB4</b>	2	4+4	700X700X150	1014X1120X430	9.2KW	380V	150 KG	INCLUIDA	60°C/450°C
<b>HPTB6</b>	2	6+6	1050X700X150	1363X1120X430	14.4KW	380V	200 KG	INCLUIDA	60°C/450°C

TEMPERATURA CONTROLADA CON PRECISIÓN, PRESERVANDO LAS CUALIDADES DEL PRODUCTO Y REALIZANDO SU SABOR Y TEXTURA  
**ACCURATELY CONTROLLED TEMPERATURE, PRESERVING THE QUALITY OF THE PRODUCT AND ENHANCING ITS FLAVOR AND TEXTURE**  
TEMPÉRATURE CONTRÔLÉE AVEC PRÉCISION PRÉSERVANT LES QUALITÉS DU PRODUIT ET VALORISANT SA SAVEUR ET SA TEXTURE.

REDUCE A LA MITAD EL TIEMPO DE MARINADO Y MACERADO DE INGREDIENTES  
**REDUCES TIME IN HALF OF MARINATING AND MACERATING**  
RÉDUIT DE MOITIÉ LE TEMPS DE MARINADE ET DE MACÉRATION DES INGRÉDIENTS.

INFUSIONA Y AROMATIZA ACEITES, GRASAS ETC..  
GRACIAS A LA TEMPERATURA CONTROLADA  
**INFUSES AND AROMATIZES OILS, FATS, ETC. THANKS TO THE CONTROLLED TEMPERATURE**  
INFUSE ET AROMATISE LES HUILES LES GRAISSES ETC...GRÂCE A LA TEMPÉRATURE CONTRÔLÉE

MUY POCO TIEMPO DE DEDICACIÓN DIRECTA, REALIZA OTRAS TAREAS MIENTRAS VAC COCINA PARA TI  
**IT IS NOT NEEDED TO SPEND TOO MUCH TIME; YOU CAN DO OTHER THINGS WHILE VAC COOKS FOR YOU**  
TRÈS PEU DE TEMPS D'OCCUPATION DIRECTE EN RÉALISANT D'AUTRES TÂCHES PENDANT QU'IL CUISINE POUR VOUS.

CONTROL HACCP EFECTIVO  
**EFFECTIVE HACCP CONTROL**  
CONTRÔLE HACCP EFFICACE



PERMITE COCINAR PRODUCTOS CON SUS PROPIOS JUGOS  
**ALLOWS FOODS TO UTILIZE THEIR OWN NATURAL JUICES DURING COOKING**  
PERMET DE CUISINER LES PRODUITS DANS LEURS PROPRES JUS

PORTATIL , LLEVALO DONDE NECESITES  
**PORTABLE, TAKE IT EVERYWHERE!**  
PORTATIF, EMMENEZ-LE DANS LES ENDROITS OÙ VOUS EN AVEZ BESOIN

PERMITE AUMENTAR LOS MÁRGENES POR LA AUSENCIA DE PÉRDIDAS DE PESO EN LOS PRODUCTOS  
**YOU CAN INCREASE YOUR BENEFITS THANKS THE PRODUCT LACK OF WEIGHT LOSS**  
PERMET D'AUGMENTER LES BÉNÉFICES EN L'ABSENCE DES PERTES DE POIDS DANS LES PRODUITS

RENDIMIENTO PROFESIONAL  
**PROFESSIONAL PERFORMANCE**  
PERFORMANCE PROFESSIONNELLE



DISEÑADO PARA AQUELLOS QUE SON PRINCIPIANTES CON LA COCCIÓN AL VACÍO.

**DESIGNED FOR THOSE WHO ARE BEGINNERS WITH SOUS VIDE COOKING,**

CONÇU POUR LES DÉBUTANTS EN CUISSON SOUS VIDE.



25 L

**VAC10**

EQUIPADO CON UNA PANTALLA TÁCTIL LCD Y UN SISTEMA BLUETOOTH QUE LE PERMITE CONTROLAR EL PROCESO DE COCCIÓN DE FORMA REMOTA MEDIANTE UNA APLICACIÓN INTERACTIVA.

**EQUIPPED WITH AN LCD TOUCH SCREEN AND A BLUETOOTH SYSTEM THAT ALLOWS YOU TO CONTROL THE COOKING PROCESS REMOTELY BY USING AN INTERACTIVE APP**

EQUIPÉ D'UN ÉCRAN TACTILE LCD ET D'UN SYSTÈME BLUETOOTH QUI PERMET DE SURVEILLER LE PROCESSUS DE CUISSON À DISTANCE GRÂCE À UNE APPLICATION INTERACTIVE.

TERMOCIRCULADOR PROFESIONAL PARA COCCIÓN AL VACÍO A BAJA TEMPERATURA FIABLE Y RESISTENTE.

**RELIABLE AND RESISTANT PROFESSIONAL THERMAL CIRCULATOR FOR SOUS VIDE COOKING.**

THERMOPLONGEUR PROFESSIONNEL POUR LA CUISSON SOUS VIDE À BASSE TEMPÉRATURE, FIABLE ET RÉSISTANT.



50 L

**VAC30**

PANTALLA PARA CONTROLAR EL TIEMPO DE COCCIÓN Y LA TEMPERATURA DEL AGUA, 10 PROGRAMAS INTEGRADOS PARA REPRODUCIR SUS RECETAS EXITOSAS CON SONDA AL CORAZÓN PARA UNA COCCIÓN PRECISA, UNIFORME Y REPRODUCIBLE.

**COOKING TIME AND WATER TEMPERATURE DISPLAY, 10 INTEGRATED PROGRAMS TO REPRODUCE YOUR SUCCESSFUL RECIPES WITH A CORE PROBE FOR PRECISE, UNIFORM AND REPRODUCIBLE COOKING.**

AFFICHAGE DU TEMPS DE CUISSON ET DE LA TEMPÉRATURE DE L'EAU, 10 PROGRAMMES INTÉGRÉS POUR REPRODUIRE VOS MEILLEURES RECETTES ET SONDE À CŒUR POUR UNE CUISSON PRÉCISE, UNIFORME ET REPRODUCIBLE

BAÑO TERMOSTÁTICO PARA COCCIÓN A BAJA TEMPERATURA DE PRODUCTOS AL VACÍO.

**THERMOSTATIC BATH FOR SOUS VIDE COOKING OF VACUUM PACKAGED PRODUCTS.**

BAIN-MARIE POUR LA CUISSON À BASSE TEMPÉRATURE DE PRODUITS SOUS VIDE



25 L

**VAC50**

ESTRUCTURA COMPLETAMENTE EN ACERO INOXIDABLE (AISI 304), PANEL DIGITAL CON 10 PROGRAMAS, TEMPORIZADOR, MEMORIA INTERNA, PRÁCTICO CESTO CON SEPARADORES EXTRAÍBLES, SONDA AL CORAZÓN E INICIO DIFERIDO.

**STAINLESS STEEL (AISI 304) BODY, DIGITAL PANEL WITH 10 PROGRAMS, TIMER, INTERNAL MEMORY, PRACTICAL BASKET WITH REMOVABLE DIVIDERS, CORE PROBE AND DELAYED START.**

CORPS ENTIÈREMENT EN ACIER INOX (AISI 304), PANNEAU NUMÉRIQUE AVEC 10 PROGRAMMES, MINUTEUR, MÉMOIRE INTERNE, PANIER PRATIQUE AVEC SÉPARATEURS AMOVIBLES, SONDE À CŒUR ET DÉPART DIFFÉRÉ.

	MEDIDAS	PESO	POTENCIA	VOLTAJE	PROGRAMAS	RANGO DE TEMPERATURAS	LITROS MAXIMO	AVISO NIVEL AGUA	INICIO RETARDADO	ALARMA DE TEMP. DE COCCIÓN	CONTROL TEMP.
<b>VAC10</b>	115X90X355	1.8KG	1.100W	230V 50/60Hz	0	0.1°C - 95°C	25 L	SI	SI	SI	SI
<b>VAC30</b>	150X240X380	4KG	1.650W	230V 50/60Hz	10	0.1°C - 95°C	50 L	SI	SI	SI	SI
<b>VAC50</b>	350X660X320	13 KG	2.000W	230V 50/60Hz	10	40°C - 95°C	25 L	NO	SI	SI	SI

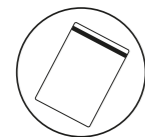

MEDIDAS	PC/CAJA
150x300	2000
200x300	1600
250x300	1000
300x400	800

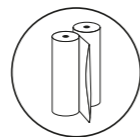

MEDIDAS	PC/CAJA
150x300	2500
200x300	2000
250x300	1600
300x400	1000



**EMB 10**

AUTOMÁTICAS  
SOLDADURA MULTINIVEL  
ANCHO DE SELLADO 3 MM  
VACÍO AUTOMÁTICO  
VACÍO EN TARROS  
BOMBA DE ALTO VACÍO

*AUTOMATIC  
MULTILEVEL WELDING  
4 MM WELDING WIDTH  
AUTOMATIC VACUUM  
VACUUM IN JARS  
HIGH PERFORMANCE VACUUM  
PUMP*



**EMB 30**

AUTOMATIQUES  
SOUDURE MULTI NIVEAUX  
LARGEUR SOUDURE 4 MM  
VIDE AUTOMATIQUE  
VIDE EN RÉCIPENT  
POMPE À VIDE ÉLEVÉ



TIRA ABSORBENTE  
ABSORBENT BAND  
180X50 - (30U) -  
230X50 - (30U) -  
280X50 - (30U) -

	MEDIDAS	PESO	POTENCIA	VOLTAJE	VACIO EN TARROS	SOLDADURA BOLSAS COCCIÓN	BOMBA	VACIO FINAL	BARRA DE SOLDADURA
<b>EMB 10</b>	385X300X170	6 KG	3.800 W	230V 50/60Hz	SI	SI	13 L / MIN	250 mbar	330 mm
<b>EMB 30</b>	470X305X180	8 KG	4.500 W	230V 50/60Hz	SI	SI	21 L / MIN	250 mbar	430 mm



**EMB 10C**

ABERTURA CARROCERÍA A 90°  
CICLO DE VACÍO TEMPORIZADO  
SOLDADURA ANTICIPATA  
TAPA CON PISTONES  
CUBETA REDONDEADA EN ACERO  
BARRA CON PISTONES INALÁMBRICOS

*BODYWORK OPENING AT 90°  
TIMED VACUUM CYCLE  
ADVANCE OF WELDING  
LID WITH PISTONS  
ROUND STEEL TANK  
WIRELESS SEALING BARS*

OUVERTURE CLASSIQUE À 90°  
CYCLE DE VIDE TEMPORISÉ  
SOUDURE ANTICIPÉE  
COUVERCLE À PISTONS  
CUVE EN ACIER ARRONDIE  
BARRE AVEC PISTONS SANS FIL

DISPLAY LCD EN 5 IDIOMAS  
20 PROGRAMAS SOFT VACUUM  
CUBETA REDONDEADA EN ACERO  
BARRA CON PISTONES INALÁMBRICOS  
BARRA DOBLE SOLDADURA (OPT.)  
SENSOR DE VACÍO (OPT.)  
IMPRESORA+TECLADO IMPERMEABLE (OPT.)

*LCD DISPLAY IN 5 LANGUAGES  
20 SOFT VACUUM PROGRAMS  
ROUND STEEL TANK  
WIRELESS SEALING BARS  
DOUBLE SEAL BAR (OPT.)  
VACUUM SENSOR (OPT.)  
PRINTER+WATERPROOF KEYBOARD (OPT.)*

AFFICHAGE LCD EN 5 LANGUES  
20 PROGRAMMES SOFT VACUUM  
CUVE EN ACIER ARRONDIE  
BARRE AVEC PISTONS SANS FIL  
BARRE DOUBLE SOUDURE (OPT.)  
CAPTEUR DE VIDE (OPT.)  
IMPRIMANTE+CLAVIER (OPT.)



**EMB 30C**

	MEDIDAS	PESO	POTENCIA	VOLTAJE	DIMENSIONES DE LA CAMARA	BOMBA	VACIO FINAL	BARRA DE SOLDADURA	ESTANTE PARA LÍQUIDOS
<b>EMB 10C</b>	500X585X450	54 KG	1,2 KW	230V 50/60Hz	430X430X180	18 M³/h	99.9%	420mm	SI (OP.150e)
<b>EMB 30C</b>	560X595X560	60 KG	1.4 W	230V 50/60Hz	430X430X220	21 M³/h	99.9%	420 mm	SI (OP.)

CUERPO DE ACERO INOXIDABLE (AISI 304)  
STAINLESS STEEL BODY (AISI 304)  
CORPS EN ACIER INOX (AISI 304)



CONTROL DIGITAL  
DIGITAL CONTROL  
CONTROLE DIGITAL

**SELL150**

GUIAS ADAPTABLES A LAS DIFERENTES BANDEJAS  
GUIDES ADAPTABLE TO THE DIFFERENT TRAYS  
GUIDES ADAPTABLES AUX DIFFÉRENTS PLATEAUX



	MEDIDAS	PC / CAJA
<b>BSELL-63</b>	137x95x63	1280
<b>BSELL-38</b>	192x136x38	330
<b>BSELL-50</b>	192x136x50	320

MANGO ERGONOMICO  
ERGONOMIC HANDLE  
POIGNÉE ERGONOMIQUE



**SELL200**

PORTATIL, LLEVALO DONDE NECESITES  
PORTABLE, TAKE IT EVERYWHERE!  
PORTATIF, EMMENEZ-LE DANS LES ENDROITS  
OÙ VOUS EN AVEZ BESOIN

	MEDIDAS	PC / CAJA
<b>BSELL-63</b>	137x95x63	1280
<b>BSELL-38</b>	192x136x38	330
<b>BSELL-50</b>	192x136x50	320
<b>BSELL-65</b>	230x190x65	300
<b>BSELL-95</b>	260x190x95	230

	MEDIDAS	PESO	POTENCIA	VOLTAJE	DIMENSIONES DE LA BANDEJA	FUNCIONAMIENTO	MOLDE FUJO	MOLDE PERSONALIZADO
<b>SELL150</b>	200X490X450	9 KG	0,6 KW	230V 50/60Hz	192X137X100	MANUAL	INCLUIDO	BAJO PEDIDO
<b>SELL200</b>	275X580X600	12 KG	0,6 W	230V 50/60Hz	260X190X100	MANUAL	INCLUIDO	BAJO PEDIDO



**LIM 100**

CUERPO DE ACERO INOXIDABLE (AISI 304)  
ALTOS ESTÁNDARES DE HIGIENE  
CICLOS DE LIMPIEZA EFICIENTES  
CUBETA INTERIOR A PRUEBA DE GOLPES EN RESINA ALIMENTARIA CONSUMOS REDUCIDOS CON BAJO IMPACTO AMBIENTAL

STAINLESS STEEL BODY (AISI 304)  
HIGH HYGIENE STANDARDS  
EFFICIENT CLEANING CYCLES  
SHOCKPROOF INNER TANK IN FOOD RESIN  
LOW CONSUMPTION WITH LOW ENVIRONMENTAL IMPACT

CORPS EN ACIER INOX (AISI 304)  
STANDARDS D'HYGIÈNE ÉLEVÉS  
CYCLES DE NETTOYAGE EFFICACES  
BAC INTÉRIEUR ANTICHOC EN RÉSINE ALIMENTAIRE CONSOMMATION ET IMPACT SUR L'ENVIRONNEMENT RÉDUITS.



**LIM 300**

SE RECOMIENDA SUBSTITUIR EL POLVO DE MAZORCA DE MAÍZ AL MENOS CADA 3 MESES  
WE RECOMMEND TO REPLACE THE CORN COB POWDER AT LEAST EVERY 3 MONTHS  
IL EST RECOMMANDÉ DE REMPLACER LES GRANULÉS TOUS LES 3 MOIS MAXIMUM.



POLVO DE MAIZ  
CORN COB POWDER  
GRANULÉS DE MAÏS

PEDIDO MÍNIMO 1 CAJA (5 BOLSAS)  
MINIMUM ORDER 1 BOX (5 BAGS)  
COMMANDE MINIMUM / 1 BOITE DE 5 SACHETS

	MEDIDAS	PESO	POTENCIA	VOLTAJE	CONSTRUCCIÓN	PRODUCTIVIDAD	LÁMPARA UV	SOPORTE CESTO CUBIERTOS
<b>EMB 10C</b>	600X550X460	53 KG	0,5 KW	230V 50/60Hz	ACERO INOX	3000 CUBIERTOS/HORA	SI	NO
<b>EMB 30C</b>	620X550X520	54 KG	0,5 W	230V 50/60Hz	ACERO INOX	3000 CUBIERTOS/HORA	SI	SI
<b>LIM 10</b>	325X300X500	1,6 KG	1,35 kW	230V 50/60Hz	ACERO INOX	350 VASOS/HORA	-	-



**LIM 10**

COMPACTO, ERGONÓMICO, FÁCIL DE USAR, EL NUEVO ABRILLANTADOR LIM 10 LE PERMITE PULIR VARIOS TIPOS DE VASOS Y COPAS, HASTA 350 POR HORA, GRACIAS A LOS 5 CEPILLOS ANTIESTÁTICOS DE MICROFIBRA Y EL FLUJO CONSTANTE DE AIRE CALIENTE A 164 CFM - 60°C.

COMPACT, INTUITIVE, EASY TO USE, THE NEW SPEEDY GLASS BESSER VACUUM ALLOWS YOU TO POLISH VARIOUS TYPES OF GLASSES, UP TO 350 PER HOUR THANKS TO THE 5 ANTI-STATIC MICROFIBER BRUSHES AS STANDARD AND THE CONSTANT HOT AIR FLOW TO 60 DEGREES.

COMPACT, ERGONOMIQUE ET FACILE À UTILISER, LE NOUVEL ESSUYEUR À VERRES SPEEDY GLASS PERMET DE POLIR DIFFÉRENTS TYPES DE VERRES, JUSQU'À 350 PAR HEURE, GRÂCE AUX 5 BROSSES ANTISTATIQUES EN MICROFIBRES ET AU DÉBIT D'AIR CHAUD CONSTANT À 60°C.



KIT DE 5 CEPILLOS EN MICROFIBRA.  
KIT OF 5 MICROFIBER BRUSHES  
KIT DE 5 BROSSES EN MICROFIBRES

CEPILLO CHAMPAGNE ALGODON  
CHAMPAGNE COTTON BRUSH  
BROSSE CHAMPAGNE EN COTON

CEPILLO CHAMPAGNE MICROFIBRA  
CHAMPAGNE COTTON MICROFIBER  
BROSSE CHAMPAGNE EN MICROFIBRES



CUBA EN ACERO INOXIDABLE  
STAINLESS STEEL TANK  
CUVE EN ACIER INOXYDABLE.

CUERPO DE ACERO DE ESPESOR GRUESO  
THICK STEEL BODY  
CORPS EN ACIER DE GROSSE ÉPAISSEUR

PREPARADA PARA MASSAS DURAS Y BLANDAS  
FOR HARD AND SOFT DOUGHS  
PRÉPARÉ POUR DES PÂTES DURES ET MOLLES.

ESPIRAL Y ASTA EN ACERO INOXIDABLE  
STAINLESS STEEL COIL AND POLE  
SPIRALE ET BRAS EN ACIER INOXYDABLE



AMS10



AMS20



AMS30

ESTRUCTURA REVESTIDA DE ESMALTE ANTIRAYADURAS  
STRUCTURE COATED WITH SCRATCH-RESISTANT TREATMENT  
STRUCTURE RECOUVERTE D'ÉMAIL ANTI RAYURES

FACILIDAD DE LIMPIEZA  
EASY CLEANING  
FACILITÉ DE NETTOYAGE.

EQUIPADAS CON RUEDAS CON FRENOS  
WHEELS WITH BRAKES INCLUDED  
ÉQUIPÉS DE ROUES ET DE FREINS

PROTECCIÓN Y CUADRO ELÉCTRICO HOMOLOGADO  
CERTIFIED PROTECTION AND ELECTRICAL PANEL  
PROTECTION ET CADRE ÉLECTRIQUE HOMOLOGUÉ

**KENWOOD**  
BATIDORA DE 7 LITROS PROFESSIONAL  
7 LITRES PROFESSIONAL BLENDER  
BATTEUR DE 7 LITRES PROFESSIONNEL



MASA PASTELES DE 20GR A 4.5KG  
CAKE DOUGH 20 GR- 4,5 KG  
PÂTE POUR PÂTISSERIE DE 20GR A 4,5KG

16 CLARAS DE HUEVO  
16 EGG WHITES  
16 BLANCS D'ŒUF

TRANSMISIÓN POR ENGRANAJE  
GEAR TRANSMISSION  
TRANSMISSION PAR ENGRENAGE

BATIDORA DE 10 LITROS  
10 LITRES BLENDER  
BATTEUR DE 10 LITRES



CUERPO CONSTRUIDO EN HIERRO FUNDIDO PINTADO EN BLANCO  
BODY MADE IN CAST IRON PAINTED IN WHITE  
CORPS CONSTRUIT EN FONTE PEINT EN BLANC

PARADA DE SEGURIDAD SI ALGUN ELEMENTO NO ESTA COLOCADO CORRECTAMENTE  
EMERGENCY STOP IF ANY ELEMENT IS NOT PLACED CORRECTLY  
ARRÊT DE SÉCURITÉ SI QUELQUE ÉLÉMENT N'EST PAS PLACÉ CORRECTEMENT

DESPLAZAMIENTO VERTICAL DEL BOWL MEDIANTE PALANCA  
VERTICAL BOWL MOVEMENT THROUGH LEVER  
DÉPLACEMENT VERTICAL DE LA CUVE AU MOYEN DU LEVIER

CUBA, PROTECCIÓN Y AGITADORES EN ACERO INOXIDABLE  
STAINLESS STEEL TANK, PROTECTION AND MIXERS  
CUVE, PROTECTION ET AGITATEURS EN ACIER INOXYDABLE

PARA ALIMENTOS LÍQUIDOS, CREAMAS Y HUEVOS  
FOR LIQUID FOODS, CREAMS AND EGGS  
POUR ALIMENTS LIQUIDES, CRÈMES ET OEUFS

PARA MASAS DE HARINA PESADAS (ALTA VISCOSIDAD)  
FOR HEAVY FLOUR DOUGHS  
POUR PÂTE LOURDE (HAUTE VISCOSITÉ)

PARA MANTEQUILLA, PASTELES, PASTA Y RELLENOS  
FOR BUTTER, CAKES, PASTA AND FILLINGS  
POUR BEURRE, GÂTEAUX, PÂTE ET GARNITURES



BATIDORA DE 20 LITROS  
20 LITRES BLENDER  
BATTEUR DE 20 LITRES



**AMASADORAS**

	TIPO	MEDIDAS	VELOCIDADES	TENSIÓN	POTENCIA	CAPACIDAD	CAPACIDAD HARINA SECA	VELOCIDAD CUBA	VELOCIDAD GANCHO	PESO
AMS10	ELÉCTRICO	730X300X635	MONOFÁSICA 1 VELOCIDAD	230V - 50HZ	400W	10L	4KG	19 RPM	193 RPM	70KG
AMS20	ELÉCTRICO	840X420X900	MONOFÁSICA 1 VELOCIDAD	230V - 50HZ	1.500W	20L	8KG	19 RPM	193 RPM	124KG
AMS30	ELÉCTRICO	1005X530X1110	TRIFÁSICA 2 VELOCIDADES	380V - 50HZ	2.500W	50L	20KG	19-13 RPM	193 RPM	177KG

**BATIDORAS**

	TIPO	MEDIDAS	VELOCIDADES	TENSIÓN	POTENCIA	CAPACIDAD	VELOCIDAD	PESO
BAT07	ELÉCTRICO	400X250X350	REGULABLE	230V - 50HZ	1.200W	6.7L	147-918 RPM	22KG
BAT10	ELÉCTRICO	470X450X600	3	230V - 50HZ	600W	10L	148 - 244 - 480 RPM	58KG
BAT20	ELÉCTRICO	540X490X780	3	230V - 50HZ	1.100W	20L	197 - 317 - 462 RPM	98KG

CRISTALES TEMPLADOS  
TEMPERED GLASS  
VITRES EN VERRE TREMPÉ

  
x18

FABRICADAS EN ACERO INOXIDABLE  
MANUFACTURED IN STAINLESS STEEL  
FABRIQUÉ EN ACIER INOX



**AV3-18**



BANDEJA DE GRAN CAPACIDAD PARA ASADO DE PATATAS Y GUARNICIONES  
LARGE CAPACITY TRAY SPECIALLY DESIGNED FOR ROASTING POTATOES & VEGETABLES  
BAC DE GRANDE CAPACITÉ POUR CUISSON DE POMMES DE TERRE OU AUTRES LÉGUMES

PIÑONES DE ACERO, FÁCIL MANTENIMIENTO Y TENSADO  
STEEL PINIONS, EASY TIGHTENING AND MINIMAL MAINTENANCE  
PIGNONS EN ACIER ENTRETIEN FACILE.

  
x24



**AV4-24**

OPCIONAL  
OPTIONAL  
EN OPTION

RESISTENCIAS DE MÁXIMA CALIDAD  
TOP QUALITY RESISTORS  
RÉSISTANCES DE QUALITÉ MAXIMALE

  
x36



**AV6-36**

INCLUIDO  
INCLUDED  
INCLUS

  
x48



**AV8-48**

	TIPO	Nº ESPADAS	Nº POLLOS	DIMENSIONES	KG	KCAL/H	KW
<b>AV3-18-E</b>	ELECTRICO	3	18	1098X480X820	80	-	9.9
<b>AV3-18-G</b>	GAS	3	18	1098X480X820	86	13.674	-
<b>AV4-24-E</b>	ELECTRICO	4	24	1098X480X1000	95	-	13.2
<b>AV4-24-G</b>	GAS	4	24	1098X480X1000	103	18.232	-

	TIPO	Nº ESPADAS	Nº POLLOS	DIMENSIONES	KG	KCAL/H	KW
<b>AV6-36-E</b>	ELECTRICO	6	36	1098X480X1860	160	-	28.8
<b>AV6-36-G</b>	GAS	6	36	1098X480X1860	170	31.800	-
<b>AV8-48-E</b>	ELECTRICO	8	48	1098X480X1920	183	-	38.4
<b>AV8-48-G</b>	GAS	8	48	1098X480X1920	193	42.400	-



25 NARANJAS POR MINUTO  
**25 ORANGES PER MINUTE**  
25 ORANGES PAR MINUTE

EXCELENTE RELACIÓN CALIDAD-PRECIO  
**EXCELLENT VALUE FOR MONEY**  
EXCELLENTE RELATION QUALITÉ-PRIX

DESMTABLE : FACILIDAD DE LIMPIEZA  
**REMOVABLE: EASY CLEANING**  
DÉMONTABLE : FACILITÉ DE NETTOYAGE



**ZUX-M**



**ZUX-EG**



**ZUX-E**

PARA NARANJAS DE ENTRE 60 Y 90 MM  
**60-90 MM ORANGE SIZE**  
POUR DES ORANGES DE 60 A 90 MM

CON ALIMENTADOR INCLUIDO  
**FEEDER INCLUDED**  
AVEC PANIER INCLUS

ROBUSTA CONSTRUCCIÓN EN ACERO INOXIDABLE  
**STAINLESS STEEL**  
ROBUSTE CONSTRUCTION EN ACIER INOXYDABLE

CUERPO ENTERO  
**FULL-STRENGHT**  
CORPS ENTIER

CON FUSIBLE SALVAMOTOR INCORPORADO  
**EQUIPPED WITH PROTECTION FUSE**  
AVEC FUSIBLE PROTÈGE MOTEUR INCORPORÉ

	MEDIDAS	POTENCIA	GRIFO	DIAM.	PRODUCCIÓN
<b>ZUX-E</b>	400x300x770	200W - 230V	NO	60-90mm	25NARANJAS/MIN
<b>ZUX-EG</b>	400x300x850	200W - 230V	SI	60-90mm	25NARANJAS/MIN
<b>ZUX-M</b>	360x240x490	230W - 230V	NO	-	-

FIABILIDAD Y FACILIDAD DE UTILIZACIÓN  
**RELIABILITY AND EASY TO USE**  
 FIABILITÉ ET FACILITÉ D'UTILISATION

FÁCIL DE USAR  
**EASY TO USE**  
 FACILITÉ D'UTILISATION

AHORRO ENERGÉTICO Y DE DETERGENTE  
**ENERGY AND DETERGENT SAVING**  
 ÉPARGNEMENT D'ÉNERGIE ET D'EAU

GRAN FIABILIDAD CON EL PASO DEL TIEMPO  
**LONG-LASTING MACHINES**  
 GRANDE FIABILITÉ DANS LE TEMPS

DISPLAY LCD CONTRUIDO CON CRISTAL TEMPLADO  
**LCD-TOUCH DISPLAY MADE WITH TEMPERED GLASS**  
 PANNEAU DE CONTRÔLE EN VÈRE TEMPRÉ ET ÉCRAN LCD-TACTILE

PARAMETROS AUTOMÁTICOS DURANTE LA PRIMERA  
 INSTALACIÓN  
**AUTOMATIC SETTING OF ALL PARAMETERS DURING THE  
 FIRST INSTALLATION**  
 RÉGLAGE AUTOMATIQUE DE TOUS PARAMÈTRES PENDANT  
 LA PREMIÈRE INSTALLATION

DOBLE DOSIFICADOR DE DETERGENTE Y ABRILLANTADOR  
 INSTALADO DE SERIE EN TODOS LOS MODELOS  
**DOUBLE DETERGENT AND RINSE-AID DISPENSER AS STANDARD  
 EQUIPMENT IN EVERY MODEL**  
 DOUBLE DOSEUR DE DÉTERGENT ET DE PRODUIT DE RINÇAGE  
 INSTALLÉ D'USINE SU TOUS MODÈLES

PRECISIÓN EN LA SELECCIÓN DE TEMPERATURAS Y DETERGENTE  
**PRECISE SETTING OF TEMPERATURES AND DETERGENT**  
 RÉGLAGE PRÉCIS DES TEMPÉRATURES ET DOSAGES DES  
 PRODUITS LESSIVIELS



**LAVAVAJILLAS ELECTRÓNICO**

	<b>K290EH</b>	<b>K540E</b>
MEDIDAS	470X555X710	585X680X815
MEDIDAS CESTA	40X40	50X50
CICLO DE LAVADO	75/90/110/130 S	90/110/120/300 S
N ° CESTAS / HORA	48	40
ALTURA MAX VIDRIO	290MM	310MM
DIÁMETRO MAX PLATO	315MM	350MM
POTENCIA RESISTENCIA	2.6KW	2.6KW
CALDERAS CALEFA. MONOFÁSICO	2.5KW	2.5KW
BOMBA DE LAVADO A PRESIÓN	0.26KW/0.35HP	0.52KW/0.7HP
POTENCIA TOTAL	2.86KW/16A	3.12KW/16A
TENSIÓN	230V	230V
TEMP. DEL AGUA RECOMENDADA	55°C	55°C
CONSUMO DE AGUA POR CICLO	2L	2L
DOSIFICADOR ELÉCTRICO DE JABÓN	SI	SI
DOSIFICADOR ELÉCTRICO DE ABRILLANTADOR	SI	SI



BRAZOS DE LAVADO Y ABRILLANTADOR DE ACERO INOXIDABLE, PARA  
 GARANTIZAR FIABILIDAD, ROBUSTEZ Y RESISTENCIA A LA CORROSIÓN.  
**STAINLESS STEEL WASHING AND RISING ARMS IN ORDER TO GRANT  
 STRENGTH, RELIABILITY AND CORROSION RESISTANCE**  
 BRAS DE LAVAGE/RINÇAGE RÉALISÉS TOTALEMENT EN ACIER INOX AFIN  
 DE GARANTIR FIABILITÉ, ROBUSTESSE ET RÉSISTANCE À CHAQUE CORROSION



FRONTAL DE FÁCIL MANTENIMIENTO  
**EASY FRONT-SIDE MAINTENANCE**  
 PRÊT ENTRETIEN FRONTAL



VELOCIDAD DE ROTACIÓN DEL ABRILLANTADOR REGULABLE  
**ADJUSTABLE RINSE ROTATION SPEED**  
 VITESSE DE RINÇAGE RÉGLABLE

FIABILIDAD Y FACILIDAD DE UTILIZACIÓN  
 RELIABILITY AND EASY TO USE  
 FIABILITÉ ET FACILITÉ D'UTILISATION

SISTEMA DE CONTROL MECÁNICO CON FRONTAL ELECTRÓNICO  
 MECHANICAL CONTROL SYSTEM WITH ELECTRONIC FRONT  
 SYSTÈME DE CONTRÔLE MÉCANIQUE AVEC AVANT ÉLECTRONIQUE



PANEL DE CONTROL CON BOTONES  
 BUTTON'S CONTROL PANEL  
 PANNEAU DE COMMANDES AVEC BOUTONS

LAVAVAJILLAS DE LARGA DURACIÓN  
 LONG LASTING MACHINES  
 FIABILITÉ DAS LE TEMPS INSUPÉRABLE

BRAZOS DE LAVADO Y ABRILLANTADOR  
 DE ACERO INOXIDABLE  
 STAINLESS STEEL WASHING AND RINSING ARMS  
 BRAS DE LAVAGE ET RINÇAGE EN ACIER INOX

FÁCIL DE USAR  
 EASY TO USE  
 GRANDE FACILITÉ D'UTILISATION

C327



C42



C432

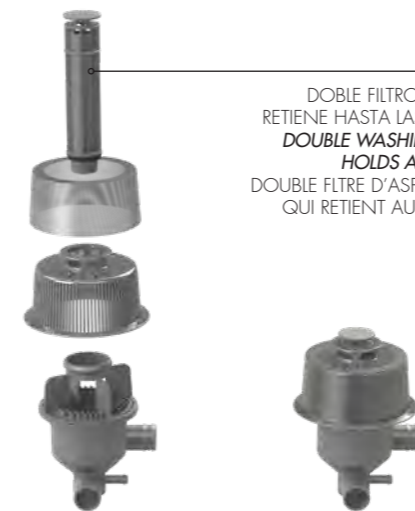

DOBLE FILTRO DE LAVADO Y DESAGÜE QUE  
 RETIENE HASTA LAS IMPUREZAS MÁS PEQUEÑAS  
 DOUBLE WASHING AND DRAIN FILTER WHICH  
 HOLDS ALSO THE SMALLEST IMPURITIES  
 DOUBLE FILTRE D'ASPIRATION LAVAGE ET VIDANGE  
 QUI RETIENT AUSSI LES PLUS PETITES IMPURITÉS

LAVAVAJILLAS MECÁNICO

	C327	C426	C432
MEDIDAS	42X50X65H	47X55.5X66H	47X55.5X69.5H
MEDIDAS CESTA	35X35X15 (CM)	40X40X15 (CM)	40X40X15 (CM)
CICLO DE LAVADO	120 SEC	120 SEC	120 SEC
N ° CESTAS / HORA	30PZ/HORA	30PZ/HORA	30PZ/HORA
ALTURA MAX VIDRIO	24CM	23,5CM	27,5CM
DIÁMETRO MAX PLATO	15CM	25.5CM	29.5CM
POTENCIA RESISTENCIA	3KW	3KW	3KW
CALDERAS CALEFA. MONOFÁSICO	3,3KW	3,3KW	3,3KW
BOMBA DE LAVADO A PRESIÓN	0,26KW/ 0,35HP	0,26KW/ 0,35HP	0,35KW/ 0,5HP
BOMBA DE LAVADO	180LT/MIN	180LT/MIN	220LT/MIN
POTENCIA TOTAL	3,56KW	3,56KW	3,56KW
TENSIÓN	230V - 50/60 HZ	230V - 50/60 HZ	230V - 50/60 HZ
TEMP. DEL AGUA RECOMENDADA	+55 ° C	+55 ° C	+55 ° C
CONSUMO DE AGUA POR CICLO	2LT/CICLO	2LT/CICLO	2LT/CICLO
DOSIFICADOR ELÉCTRICO DE JABÓN	INCLUIDO	INCLUIDO	INCLUIDO
DOSIFICADOR ELÉCTRICO DE ABRILLANTADOR	INCLUIDO	INCLUIDO	INCLUIDO



**K1100**

LAVAVAJILLAS CON CUPULA, LO MEJOR PARA LA GRAN RESTAURACION  
*PASS-THROUGH MODELS, THE BEST FOR CATERING ACTIVITIES*  
LAVE-VAISSELLE À CAPOT, LE MIEUX POUR LA GRANDE RESTAURATION

SISTEMA "PUSH TO START" QUE ASEGURA UN MENOR CONSUMO  
*"PUSH TO START" SYSTEM THAT ENSURES LESS CONSUMPTION*  
DÉMARRAGE "PUSH TO START" QUI ASSURE MOINS DE CONSOMMATIONS

SOPORTE DE LA CESTA DE FÁCIL EXTRACCIÓN  
*EASY-REMOVABLE BASKET SUPPORT*  
SUPPORT PANIER SIMPLE À ENLEVER

CUBA HIGIÉNICA EMBUTIDA  
*HYGIENIC PRINTED MOLDED TANK*  
CUVE HYGIENIQUE IMPRIMÉE ET EMBOUTIE

FILTRO DE ACERO INOXIDABLE DE SERIE INTEGRADO EN LA CUBA  
*INTEGRAL TANK STAINLESS STEEL FILTERS AS STANDARD EQUIPMENT*  
FILTRÉS INOX INTÉGRAUX DE CUVE EN DOTATION STANDARD

SISTEMA DE CONTROL MECÁNICO CON FRONTAL ELECTRÓNICO  
*MECHANICAL CONTROL SYSTEM WITH ELECTRONIC FRONT*  
SYSTÈME DE CONTRÔLE MÉCANIQUE AVEC AVANT ÉLECTRONIQUE



**C537T**

**C537**

FIJACIÓN DE LAS PUERTAS EN 20/10 PARA GARANTIZAR UNA GRAN ROBUSTEZ  
*DOOR REINFORCEMENT BRACKETS 20/10 TO GUARANTEE A TIMELESS STRENGTH*  
FIXATION DES PORTES EN 20/10 AFIN DE GARANTIR UNE ROBUSTESSE INFINIE

CUBA HIGIÉNICA EMBUTIDA E INCLINADA PARA UN MEJOR DESAGÜE  
*HYGIENIC PRINTED INCLINED TANK FOR A BETTER DRAIN*  
CUVE HYGIENIQUE IMPRIMÉE ET INCLINÉE POUR UN MEILLEUR VIDANGE



**LAVAVAJILLAS MECÁNICO**

	<b>C537</b>	<b>C537T</b>	<b>K1100</b>
MEDIDAS	58,5X68X80H	58,5X68X80H	62X76X190H
MEDIDAS CESTA	50X50X10 (CM)	50X50X10 (CM)	50X50X10 (CM)
CICLO DE LAVADO	120 SEC	120 SEC	60/90/120 SEC
N ° CESTAS / HORA	30PZ/HORA	30PZ/HORA	30/40/60PZ/HORA
ALTURA MAX VIDRIO	31CM	31CM	43CM
DIÁMETRO MAX PLATO	33CM	33CM	45.5CM
POTENCIA RESISTENCIA	3KW	3KW	2,5KW+2,5
CALDERAS CALEFA. MONOFÁSICO	3,3KW	4,5KW	4,5KW
BOMBA DE LAVADO A PRESIÓN	0,52KW/ 0,7HP	0,52KW/ 0,7HP	1,5KW/ 1,12HP
BOMBA DE LAVADO	300LT/MIN	300LT/MIN	400LT/MIN
POTENCIA TOTAL	3,82KW	5,02KW	6,74KW
TENSIÓN	230V - 50/60 HZ	400V - 50/60 HZ	400V - 50/60 HZ
TEMP. DEL AGUA RECOMENDADA	+55 ° C	+55 ° C	+55 ° C
CONSUMO DE AGUA POR CICLO	2LT/CICLO	2LT/CICLO	2LT/CICLO
DOSIFICADOR ELÉCTRICO DE JABÓN	INCLUIDO	INCLUIDO	INCLUIDO
DOSIFICADOR ELÉCTRICO DE ABRILLANTADOR	INCLUIDO	INCLUIDO	INCLUIDO



BRAZOS DE LAVADO Y ABRILLANTADOR DE ACERO INOXIDABLE, PARA GARANTIZAR FIABILIDAD, ROBUSTEZ Y RESISTENCIA A LA CORROSIÓN.  
*STAINLESS STEEL WASHING AND RISING ARMS IN ORDER TO GRANT STRENGTH, RELIABILITY AND CORROSION RESISTANCE*  
BRAS DE LAVAGE/RINÇAGE RÉALISÉS TOTALEMENT EN ACIER INOX AFIN DE GARANTIR FIABILITÉ, ROBUSTESSE ET RÉSISTANCE À CHAQUE CORROSION



PIRULETA AGBAR



GALLETA



PIRULETA CORAZÓN



PIRULETA GOFRE



MINI-DONUT



CHURROS



MINI DONNUT



CHURROS



PIRULETA AGBAR



PIRULETA GOFRE



GALLETA



PIRULETA CORAZÓN



LA FACILIDAD DE INTERCAMBIAR LAS PLACAS DE COCCIÓN, PERMITE PRODUCIR FORMAS COMPLETAMENTE DIFERENTES  
 THE EASY EXCHANGE SYSTEM ENABLES YOU TO PRODUCE COMPLETELY DIFFERENT SHAPES  
 LA FACILITÉ D'INTERCHANGER LES PLAQUES DE CUISSON PERMET DE PRODUIRE DES FORMES COMPLÈTEMENT DIFFÉRENTES

PLACAS DE COCCIÓN INTERCAMBIABLES  
 CHANGEABLE BAKING PLATES  
 PLAQUES DE CUISSON INTERCHANGEABLES

GARANTIZA EL TIEMPO EXACTO PARA CONSEGUIR EL WAFFLE PERFECTO  
 REMINDS YOU AT THE RIGHT TIME TO TAKE OFF THE WAFFLE FROM THE MACHINE  
 GARANTIE DE TEMPS EXACT POUR OBTENIR UN RÉSULTAT PARFAIT

TEMPORIZADOR DIGITAL CON SEÑAL ACUSTICA  
 DIGITAL TIMER WITH ACOUSTIC SIGNAL  
 TEMPORISATEUR DIGITAL AVEC SIGNAL ACOUSTIQUE



**MULTI-GOFRESYSTEM**

DOSIFICADOR DE MASA PRECISO  
 PRECISE DOUGH DISPENSER  
 DOSEUR DE PÂTE PRÉCIS

DOSIFICADOR AUTOMÁTICO  
 6LITROS (OPCIONAL)

PLATINA EXTRA

ESPACIO AISLANTE DE CALOR Y FÁCIL LIMPIEZA  
 HEAT INSULATION AND CLEANING SPACE  
 ESPACE ISOLANT LA CHALEUR ET NETTOYAGE FACILE

MULTI-GOFRESYSTEM CON PLATINA

MEDIDAS

POTENCIA

VOLTAJE

305x450x320/615

2.200W

230V

PARA OTROS MODELOS, CONSULTAR DISPONIBILIDAD - CHECK AVAILABILITY FOR OTHER MODELS - POUR AUTRES MODELS, CONSULTER LA DISPONIBILITÉ

ACERO ANTIADHERENTE DE ALTA CALIDAD  
 HIGH QUALITY NON-STICK CAST IRON SURFACE AREA  
 ACIER ANTIADHÉRENT DE HAUTE QUALITÉ



**PREMIUM CREPS I**

PIES REGULABLES EN ALTURA  
 HEIGHT-ADJUSTABLE FEET  
 PIEDS RÉGLABLES EN HAUTEUR

PLACA FIJA DE HIERRO FUNDIDO 400 MM  
 FIX MOUNTED CAST IRON BAKING PLATE 400MM  
 PLAQUE FIXE EN ACIER 400 MM Ø



**PREMIUM CREPS II**

	MEDIDAS	POTENCIA	VOLTAJE
<b>PREMIUM CREPS I</b>	400x400x165	3.200W	230V
<b>PREMIUM CREPS II</b>	845x400x165	3.200W + 3.200W	230V



**BURBUJAS**



**TANGO**



**DONG**

PLATINAS INTERCAMBIABLES!  
 INTERCHANGEABLE PLATES!  
 PLAQUES INTERCHANGEABLES!



180° GIRATORIO PARA UNA DISTRIBUCIÓN UNIFORME DE LA MASA  
 180° LEFT/RIGHT PIVOTING FOR OPTIMAL DOUGH DISTRIBUTION  
 180° GIRATOIRE POUR UNE DISTRIBUTION UNIFORME DE LA PÂTE



**TANGO**

PLACAS DE COCCIÓN DE ALUMINIO FIJAS  
 CON REVESTIMIENTO ANTIADHERENTE  
 NON-STICK COATED ALUMINIUM BAKING  
 PLATES FIX MOUNTED  
 PLAQUES DE CUISSON FIXES EN ALUMINIUM  
 AVEC REVÊTEMENT ANTIADHÉSIF

CARCASA DE ACERO INOXIDABLE  
 STAINLESS STEEL CASING  
 CARCASSE EN ACIER INOXYDABLE

TEMPORIZADOR DIGITAL CON SEÑAL ACUSTICA  
 DIGITAL TIMER WITH ACOUSTIC SIGNAL  
 TEMPORISATEUR DIGITAL AVEC SIGNAL ACOUSTIQUE



**GOFRES**

**BURBUJAS**

**CHURROS**

**DONG**

	MEDIDAS	PLATINAS INCLUIDAS	POTENCIA	VOLTAJE
<b>TANGO</b>	410x280x230	1	2.000W	230V

PLATINA EXTRA





**SINGLE SQUARE WAFFLE ECO**



**SINGLE CREP**



**DOUBLE CREP GAS**



**DOUBLE CREP**



**SINGLE CREP GAS**

DISEÑADAS PARA CALENTAR Y MEZCLAR CUALQUIER TIPO DE BEBIDA  
 DESIGNED TO HEAT AND MIX ANY KIND OF DRINK  
 CONÇU POUR CHAUFFER ET MÉLANGER TOUT TYPE DE BOISSON

CALENTAMIENTO POR BAÑO MARIA  
 HEATING BY BATH MARIA  
 CHAUFFAGE PAR BAIN MARIA



**CH5X**

GRIFO ESPECIAL ANTI-OBSTRUCCIÓN  
 SPECIAL ANTI-OBSTRUCTION FAUCET  
 ROBINET SPÉCIAL ANTI-OBSTRUCTION



**CH10X**

CALDERA CONSTRUIDA EN AISI304  
 BOILER BUILT IN AISI304  
 CHAUDIÈRE CONSTRUITE EN AISI304

TRITURADOR DISEÑADO PARA TODO TIPO DE COCKTAILS  
 SHREDDER DESIGNED FOR ALL KINDS OF COCKTAILS  
 BROYEUR CONÇU POUR TOUT GENRE DE COCKTAILS



**TRI120**

CONTENEDOR INTERIOR EN AISI 304  
 INTERIOR CONTAINER IN AISI 304  
 CONTENEUR INTERIEUR EN AISI 304

	MEDIDAS	TIPO	SUPERFICIE	POTENCIA	VOLTAJE
<b>SINGLE CREP ECO</b>	450X500X220	ELÉCTRICO	DIAM. 400	3.000W	230V
<b>DOUBLE CREP ECO</b>	900X500X220	ELÉCTRICO	DIAM 400 X 2	6.000W	400V
<b>SINGLE SQUARE WAFFLE ECO</b>	300X320X300	ELÉCTRICO	-	2.200W	230V
<b>SINGLE CREP GAS ECO</b>	450X500X210	GAS	DIAM. 350	5.000W	-
<b>DOUBLE CREP GAS ECO</b>	930X500X210	GAS	DIAM 350 X 2	10.000W	-

	MEDIDAS	CAPACIDAD	POTENCIA	TEMP.
<b>CH5X</b>	410x280x465	5 LITROS	1000W - 230V	+30°C/+100°C
<b>CH10X</b>	410x280x580	10 LITROS	1000W - 230V	+30°C/+100°C

	MEDIDAS	POTENCIA	ESPESOR	PRODUCCIÓN
<b>TRI120</b>	290x360x450	360W - 230V	FINO - 2.5mm	120kg/h

# ESTERILIZADORES PROFESIONALES DE DOBLE ACCIÓN



**EST450**



**EST600**



**EST900**

	DIMENSIONES	PESO	POTENCIA	TENSIÓN	CAPACIDAD RECOMENDADA	DECIBELOS	FILTRADO DE AIRE	LÁMPARAS UV	POTENCIA UV	DURABILIDAD UV	GENERADOR OZONO	CAPACIDAD DE OZONO	DESTRUCCIÓN DEL OZONO
<b>EST450S</b>	700X360X260	18KG	350W	230 V -50Hz	450m3	45dB	2 ETAPAS	SI (UV-C 253.7mm)	54 W	9.000h	NO	-	-
<b>EST450</b>	700X360X260	18KG	350W	230 V -50Hz	450m3	45dB	2 ETAPAS	SI (UV-C 253.7mm)	54 W	9.000h	SI	30.000 mg/h	SI
<b>EST600</b>	950X360X260	20KG	500W	230 V -50Hz	600m3	43dB	2 ETAPAS	SI (UV-C 253.7mm)	100 W	9.000h	SI	45.000 mg/h	SI
<b>EST900</b>	1050X700X490	35KG	660W	230 V -50Hz	900m3	42dB	2 ETAPAS	SI (UV-C 253.7mm)	150 W	9.000h	SI	60.000 mg/h	SI

## DESINFECCIÓN DE PATÓGENOS PATHOGENIC DISINFECTION DÉSINFECTION DES AGENTS PATHOGÈNES



LAS BACTERIAS, VIRUS Y OTROS PATÓGENOS SE TRANSFIEREN AL ESTERILIZADOR  
**BACTERIA, VIRUS AND PATHOGENS ARE TRANSFERRED TO THE STERILIZER**  
LES BACTÉRIES, VIRUS, ET AUTRES AGENTS PATHOGÈNES SE TRANSFÈRENT DANS LE STÉRILISATEUR.



PREFILTRACIÓN DE PARTÍCULAS  
**PRE-FILTRATION OF PARTICLES**  
PRE-FILTRATION DES PARTICULES



LOS PATÓGENOS EN EL AIRE SON EXPUESTOS A LA RADIACIÓN UV-C.  
**AIR PATHOGENS ARE EXPOSED TO UV-C RADIATION**  
LES AGENTS PATHOGÈNES DANS L'AIR SONT EXPOSÉS A LA RADIATION UV-C



LA ESTRUCTURA MOLECULAR DEL ADN DE LOS PATÓGENOS SE DESCOMPONE, LO QUE LOS NEUTRALIZA POR COMPLETO  
**MOLECULAR STRUCTURE OF THE PATHOGENS' DNA IS DECOMPOSED AND THEY ARE COMPLETELY NEUTRALISED**  
LA STRUCTURE MOLÉCULAIRE DE L'ADN DES AGENTS PATHOGÈNES SE DÉCOMPOSE CE QUI LES NEUTRALISENT COMPLÈTEMENT



EL AIRE LIMPIO SE DEVUELVE A LA HABITACIÓN A TRAVÉS DE UN SEGUNDO FILTRO DE SALIDA  
**CLEAN AIR IS RETURNED TO THE ROOM THROUGH A SECOND OUTPUT FILTER**  
L'AIR PROPRE SE RETIRE DE L'HABITACLE AU MOYEN D'UN SECOND FILTRE DE SORTIE

## ESTERILIZACIÓN CON OZONO OZONE STERILIZATION STÉRILISATION AVEC OZONE



EL OXÍGENO MOLECULAR CONTENIDO EN EL AIRE SE SUMINISTRA A UN GENERADOR DE OZONO UBICADO DENTRO DEL ESTERILIZADOR  
**THE MOLECULAR OXYGEN CONTAINED IN THE AIR IS DELIVERED TO A OZONE GENERATOR LOCATED WITHIN THE STERILIZER**  
L'OXYGÈNE MOLÉCULAIRE CONTENU DANS L'AIR EST FOURNI PAR LE GÉNÉRATEUR D'OZONE SITUÉ DANS LE STÉRILISATEUR



DESCARGAS DE CORONA SEPARAN LAS MOLÉCULAS DE OXÍGENO.  
**CORONA DISCHARGES SEPARATE OXYGEN MOLECULES**  
LA COURONNE DÉCHARGE DES MOLÉCULES D'OXYGÈNE SÉPARÉES



LOS ÁTOMOS DE OXÍGENO INDIVIDUALES SE UNEN CON LAS MOLÉCULAS DE OXÍGENO PARA FORMAR MOLÉCULAS DE OZONO (O3).  
**INDIVIDUAL OXYGEN ATOMS BOND WITH OXYGEN MOLECULES TO FORM OZONE MOLECULES**  
LES ATOMES D'OXYGÈNE INDIVIDUELS S'UNISSENT AVEC LES MOLÉCULES D'OXYGÈNE POUR FORMER DES MOLÉCULES D'OZONE (O3)

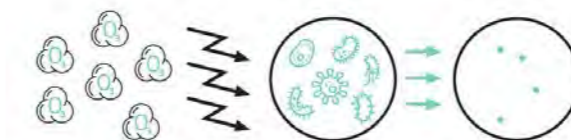

LA CONCENTRACIÓN DE OZONO LLEGA A TODOS LOS RINCONES DE LA HABITACIÓN, NEUTRALIZANDO LOS PATÓGENOS.  
**THE CONCENTRATION OF OZONE REACHES EVERY CORNER OF THE ROOM, NEUTRALIZING PATHOGENS**  
LA CONCENTRATION D'OZONE ARRIVE DANS TOUS LES COINS DE L'HABITACLE NEUTRALISANT LES AGENTS PATHOGÈNES



UNA VEZ QUE SE COMPLETA EL PROCESO DE ESTERILIZACIÓN, LA UNIDAD ENTRA EN MODO DE DESTRUCCIÓN DE OZONO UV, HASTA OBTENER UNA ESTANCIA SEGURA PARA EL USUARIO.  
**ONCE THE STERILIZATION PROCESS IS COMPLETED, THE UNIT GOES INTO UV OZONE DESTRUCTION MODE, UNTIL A SAFE ATMOSPHERE IS OBTAINED**  
UNE FOIS QUE SE TERMINE LE PROCESSUS DE STÉRILISATION, L'UNITÉ ENTRE EN MODE DE DESTRUCTION D'OZONE UV JUSQU'À OBTENIR UNE SÉCURITÉ POUR L'UTILISATEUR



UNA VEZ QUE SE ALCANZA LA CONCENTRACIÓN SEGURA DE OZONO, SE COMPLETA EL CICLO DE ESTERILIZACIÓN Y EL ESTERILIZADOR ENTRA EN MODO DE STANDBY.  
**ONCE A SAFE CONCENTRATION OF OZONE IS REACHED, THE STERILIZATION CYCLE IS COMPLETED AND THE STERILIZER GOES INTO STAND-BY MODE**  
UNE FOIS QUE LA CONCENTRATION SÛRE D'OZONE EST ATTEINTE, LE CYCLE DE STÉRILISATION SE TERMINE ET LA STÉRILISATION ENTRE EN MODE STAND-BY



LA HABITACIÓN ES ESTÉRIL, LIBRE DE PATÓGENOS Y NEUTRALIZADA DE TODO TIPO DE OLORES.  
**THE ROOM BECOMES STERILE, FREE OF PATHOGENS AND NEUTRALISED AGAINST ALL TYPES OF ODOURS**  
L'HABITACLE EST STÉRILE, LIBRE D'AGENTS PATHOGÈNES, ET NEUTRALISÉ DE TOUT TYPE D'ODEUR.

VITRINA ROBUSTA DE DISEÑO CLÁSICO  
STURDY CLASSIC DESIGN SHOWCASE  
ROBUSTE VITRINE DE CLASSIQUE DESIGN

ILUMINACION TIRA DE LED  
LED STRIP LIGHTING  
ÉCLAIRAGE LED STRIP



V8SA

+++  
+90°C

BANDEJAS INCLUIDAS GN 1/3 X 40  
GN 1/3 X 40 TRAYS INCLUDED  
PLATEAU INCLUS GN 1/3 X 40

DESAGÜE PARA FACILITAR LA LIMPIEZA  
EASY CLEANING DRAINAGE  
ÉGOUTTER POUR UN NETTOYAGE FACILE



C6SA



V6SA

CONTROL DIGITAL DE LA TEMPERATURA  
DIGITAL TEMPERATURE CONTROL  
CONTRÔLE DIGITAL DE LA TEMPERATURE

CRISTAL ABATIBLE  
FOLDING GLASS  
PLIANTE VERRE



V4SA



C4SA

	TIPO	MEDIDAS	CUBA	BANDEJAS	TEMP.	LED
V4SA	REFRIGERADO	1085x395x245	40mm	4 GN 1/3x40	+2/+6°C	SI
V6SA	REFRIGERADO	1438x395x245	40mm	6 GN 1/3x40	+2/+6°C	SI
V8SA	REFRIGERADO	1788x395x245	40mm	8 GN 1/3x40	+2/+6°C	SI
C4SA	CALENTADOR	840x395x245	40mm	4 GN 1/3x40	+90°C	NO
C6SA	CALENTADOR	1190x395x245	40mm	6 GN 1/3x40	+90°C	NO

## CONDICIONES DE VENTA

### PEDIDOS

La solicitud de pedidos deberá dirigirse a nuestras instalaciones centrales en Sayl Barcelona S.L. vía e-mail a la siguiente dirección de correo electrónico: info@saylbarcelona.com  
Desde Sayl Barcelona SL se enviará una confirmación del pedido que el cliente deberá verificar e informarnos de si observa algún tipo de discrepancia. De no recibir ninguna notificación al respecto, se dará por entendido que es correcto y se procederá a su gestión habitual. Una vez efectuada la expedición los pedidos no podrán anularse.

### PORTES

La mercancía se envía a portes pagados a partir de un importe mínimo neto de 500,00€ en Península (resto a consultar). En este caso, Sayl Barcelona S.L. se hará cargo de los daños derivados del transporte siempre y cuando se haga constar en el albarán de transporte en el momento de la recepción de la mercancía, los desperfectos ocasionados. En caso de que el albarán no estuviera perjudicado, no se aceptarán reclamaciones. El comprador tiene 24 horas para notificar cualquier anomalía. Pasado este periodo, Sayl Barcelona S.L. no podrá atender ninguna reclamación por este motivo.

### EMBALAJE

El embalaje estándar de SAYL Barcelona SL está incluido en el precio. Los embalajes marítimos y especiales, se cargarán en factura.

### GARANTÍA

La garantía es válida por un periodo de 12 meses a partir de la fecha de factura del distribuidor o el número de serie/fabricación de la máquina. Todos los componentes quedan cubiertos por esta garantía, exceptuando los cristales y el equipo eléctrico o electrónico sujetos a variaciones impredecibles de tensión. La garantía quedará anulada si el aparato se ha sometido a un mal uso, el mantenimiento ha sido defectuoso y la sociedad haya perjudicado cualquier elemento de la máquina. En ningún caso la garantía cubre los gastos de transporte, mano de obra, ni indemnizaciones de ningún tipo. SAYL Barcelona S.L. se reserva el derecho de solicitar el envío de la pieza a sustituir sin cargo y a portes pagados para su comprobación.

### PRECIOS

Los precios que figuran en la presente tarifa son precios venta al público y no incluyen los impuestos vigentes. SAYL Barcelona SL se reserva el derecho de modificar los precios sin previo aviso. En caso de ser necesario un montaje o instalación, este correrá a cargo del comprador.

### FORMA DE PAGO

El pago de las facturas será realizado al contado en nuestras instalaciones, o por transferencia bancaria antes de la salida del material. Si se otorga crédito al cliente, el pago se efectuará en la forma y lugar convenidos.

### DEVOLUCIONES

No se admitirán devoluciones salvo expresa autorización de Sayl Barcelona SL. En todo caso el material debe remitirse en su embalaje original, libre de portes y gastos. Se abonará al cliente como máximo el 90% de su precio de venta siempre que el material se encuentre en perfectas condiciones y no haya sido utilizado ni desprecintado. El 10% restante se facturará en concepto de gastos de revisión y nuevo embalaje, junto con los portes de ida en caso de que hayan sido abonados por SAYL Barcelona S.L. Los importes abonados en concepto de la máquina devuelta, se mantendrán en la cuenta del cliente y serán descontados en la próxima factura.

### RECAMBIOS

Los recambios retirados de nuestros almacenes serán pagados en efectivo. El envío de los mismos será siempre previa transferencia y con portes debidos o cargados en factura. La facturación mínima será de 30€.

### PROPIEDAD DE LA MERCANCIA

Continúa siendo propiedad de Sayl Barcelona SL toda la mercancía que no esté totalmente pagada aunque permanezca en stock del comprador.

### JURISDICCIÓN

En caso de litigio, serán los tribunales de Barcelona a los que las dos partes se someten con renuncia a cualquier otro fuero que pudiese corresponder.

SAYL BARCELONA S.L. En su afán de mejorar e innovar se reserva el derecho de efectuar variantes de diseño, fotografías, características técnicas y acabados sin previo aviso.

## TERMS AND CONDITIONS OF SALE

### ORDERS

The orders have to be addressed to Sayl Barcelona SL by email to info@saylbarcelona.com. The company will send an order confirmation. The client must check if the information is correct and inform the company if there is any kind of discrepancy. If we do not receive any reply, we understand that the order is correct and we will proceed as usual. Once the order has been sent it will not be possible to cancel it.

### SHIPPING FEES

Shipping fees are included if the net amount is more than 500 € to the Peninsula (the rest to be consulted). In this case, SAYL Barcelona SL will cover the cost of the damaged occurred during transport provided that it is mentioned at the delivery note.

There are 24 hours to make a complaint. After this time, we will not attend any complain for this reason.

### PACKAGING

Standard packaging is included in the price. Special and maritime packaging will be charged.

### GUARANTEE

The guarantee is valid for a period of 12 months from the billing date or the serial number. All the components are covered by the guarantee, except for the glasses and the electrical unit subject to unforeseen power variations. The guarantee will be cancelled if the item has been subject to an incorrect use or maintenance. The guarantee does not cover in any case, the shipment fee, labour cost or any kind of compensation. If an item has to be checked, the company reserves the right to ask for the shipment of the good free of charge.

### PRICES

The prices of the catalogue are public prices and do not include taxes. The company reserves the right to modify the prices without notice. If there is need of installation, this will be charged apart.

### METHOD OF PAYMENT

Payment has to be made in our facilities in cash or via bank transfer before the shipment of the goods. If the client has credit, the payment will be made as agreed.

### RETURN POLICY

No refunds will be made unless there is an express authorization from SAYL Barcelona SL. In any case, the items must be returned free of shipment fees. The company will refund a maximum of 90% of the selling price provided that the equipment is in perfect conditions and has not been used. The other 10% will be charged as inspection, packing and delivery fees.

### SPARE PARTS

The spare parts collected in our premises will be paid in cash. Payment has to be made by bank transfer if the spare parts have to be sent. There has to be a minimum purchase of 30€.

The equipment that is not fully paid is property of SAYL Barcelona S.L. even if the equipment it's on the buyer's premises.

### JURISDICTION

Any disputes that may arise between the parties related to this agreement shall be submitted to the Courts and Tribunals of Barcelona

SAYL BARCELONA S.L. reserves the right to change the design, technical details, pictures or any other characteristic of the equipment without prior notice. The photos and measures presented in this catalogue are not contractual. We highly recommend the clients to ask for a technical drawing in case of installation.

This price list supersedes all previous versions.

**¿ PORQUÉ LA ELECCIÓN DE LA VITRINA ES TAN IMPORTANTE PARA UN NEGOCIO ?  
WHY IS IT SO IMPORTANT FOR YOUR BUSINESS THE ELECTION OF THE DISPLAY CASE ?  
POURQUOI LE CHOIX DE LA VITRINE EST SI IMPORTANT POUR UN COMMERCE ?**

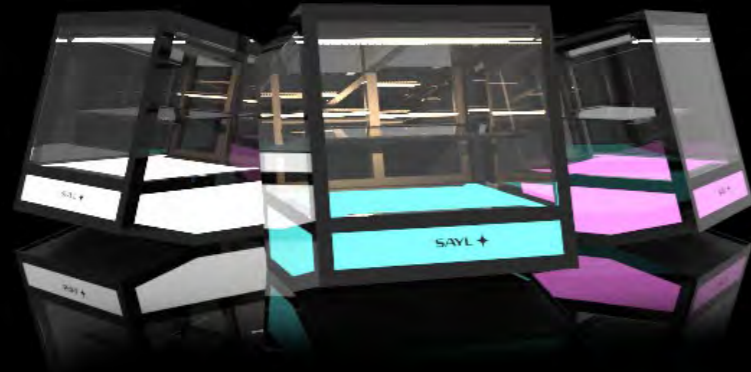

**PUBLICIDAD  
ADVERTISING  
PUBLICITÉ**

Es el mejor medio publicitario, el más directo y el que mejor convierte.  
*It encourages the purchase as it is the best advertising medium.*  
C'est la meilleure publicité la plus directe et celle qui convertit le mieux.



**RENTABILIDAD  
COST EFFECTIVENESS  
RENTABILITÉ**

La vitrina es el vendedor silencioso y más rentable de tus productos.  
*The display case is a silent seller and your most profitable product.*  
Le vitrine c'est le vendeur silencieux et plus rentable de vos produits.



**AUMENTO VALOR  
INCREASE VALUE  
AUGMENTER LA VALEUR**

Dependiendo de la vitrina el consumidor percibirá mayor o menor valor del producto expuesto.  
*Depending on the display case, the seller will perceive a greater or lesser value of the exhibited product.*  
Dépendant de la vitrine, le consommateur percevra la valeur plus ou moins grande du produit exposé.



**MUESTRA Y CONSERVA  
SHOWS AND PRESERVES  
MONTRER ET GARDER**

Lo que no se ve, no se vende,  
Lo que no se conserva bien, no apetece.  
*What it is not seen, can not be sold.*  
*What it is not well preserved, it is not appealing.*  
Ce qui ne se voit pas ne se vend pas  
Ce qui se conserve mal ne donne pas envie.



**RESPONSABILIDAD  
RESPONSIBILITY  
RESPONSABILITE**

Es el primer impacto que recibe el consumidor al entrar al establecimiento y tiene gran responsabilidad sobre su idea del mismo.  
*It is the first impact that the customer receives and it has responsibility in the image that he creates about your business*  
C'est le premier impact que reçoit le consommateur en rentrant dans l'établissement et il a une grande responsabilité à propos de son idée.



**LA SUMA MULTIPLICA, LA RESTA DIVIDE  
THE SUM MULTIPLIES, THE SUBTRACTION DIVIDES  
LA SOMME MULTIPLIES, LE REPOS SE DIVISE**

Un buen producto con una buena exposición es un tandem imbatible, un buen producto con una mala exposición sale caro.  
*A good product with a good exhibition is an unbeatable tandem. a good product with a bad exhibition, can become expensive.*  
Un bon produit avec une bonne exposition c'est un tandem imbattable, un bon produit avec une mauvaise exposition cela revient cher.

**SAYL** ✨

SAYL BARCELONA S.L. | C/ CAN CUYÁS NUM. 80 – POLÍGONO INDUSTRIAL CAN CUYÁS 08110 MONTCADA I REIXAC | BARCELONA - SPAIN

(0034) 93-515-14-15 | info@saylbarcelona.com | www.saylbarcelona.com